

# UNH/NOAA Joint Hydrographic Center Performance and Progress Report

Project Title: Joint Hydrographic Center  
Report Period: 01/01/2013 – 12/31/2013

Principal Investigator:  
Larry A. Mayer

NOAA Ref No: NA10NOS4000073



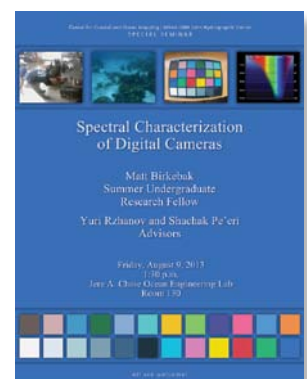
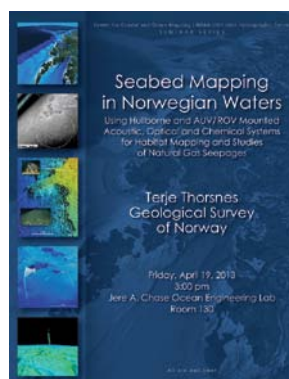
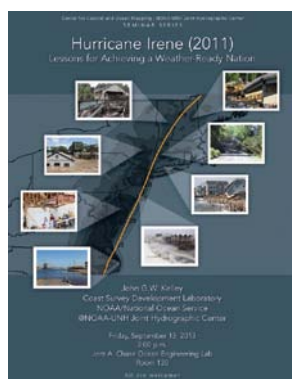
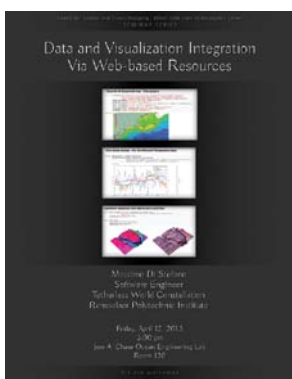
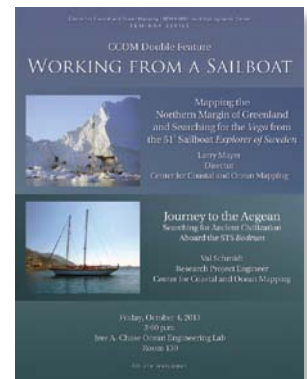
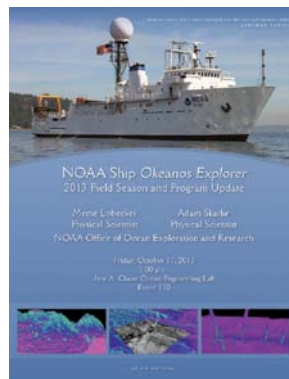
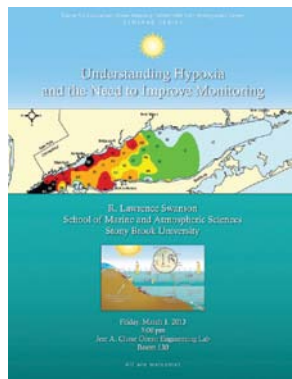
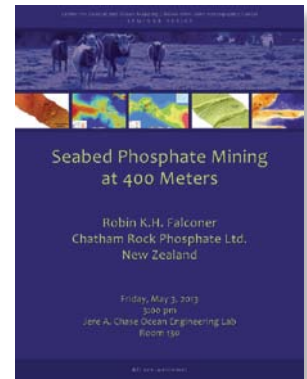
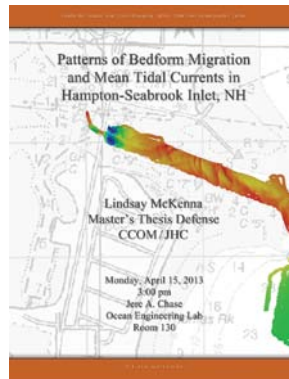
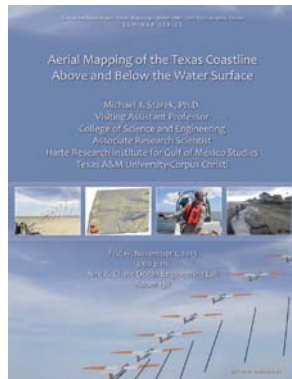
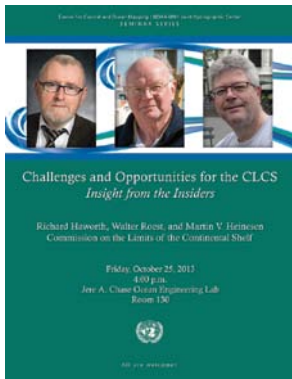
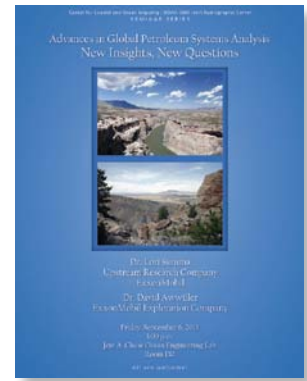
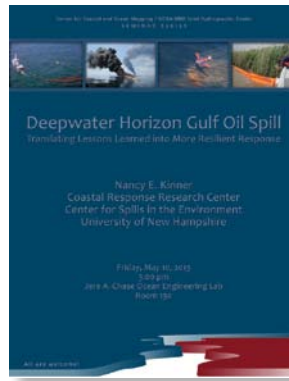
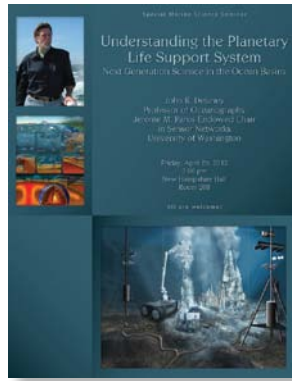
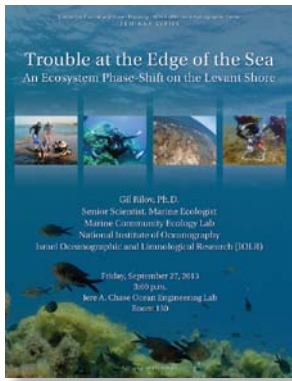

Flyers from the 2013 JHC/CCOM Seminar Series.



<b>EXECUTIVE SUMMARY</b> .....	<b>5</b>
INTRODUCTION .....	5
HIGHLIGHTS FROM OUR 2013 PROGRAM .....	7
<b>INTRODUCTION</b> .....	<b>22</b>
<b>INFRASTRUCTURE</b> .....	<b>22</b>
PERSONNEL .....	22
Faculty .....	23
Research Scientists and Staff .....	26
NOAA Employees.....	29
Other Affiliated Faculty.....	31
Visiting Scholars.....	31
FACILITIES, IT AND EQUIPMENT.....	34
Office and Teaching Space.....	34
Laboratory Facilities.....	34
Pier Facilities.....	36
Information Technology .....	36
Research Vessels.....	40
<b>EDUCATIONAL PROGRAM</b> .....	<b>45</b>
CURRICULUM DEVELOPMENT.....	45
JHC–ORIGINATED COURSES .....	46
MODULES .....	46
GEBCO CERTIFICATE PROGRAM .....	46
HYDROGRAPHIC FIELD COURSE.....	49
EXTENDED TRAINING.....	50
<b>STATUS OF RESEARCH: JANUARY–DECEMBER 2013</b> .....	<b>52</b>
■ <b>THEME 1 - Improving the Sensors Used for Hydrographic, Ocean and Coastal Mapping (Sonar, Lidar, AUVs, etc.) with Emphasis on Increasing Accuracy, Resolution, and Efficiency, Especially in Shallow Water</b> .....	<b>53</b>
Sonars .....	53
Very Shallow Water Surveying—CBASS .....	58
Sea Acceptance Trials—Multibeam Advisory Committee .....	59
Collaborative Support of NOAA Sonar Systems .....	61
Lidar .....	62
Sound Speed Sensors.....	62
AUV Activities .....	63
■ <b>THEME 2 - Improving and Developing New Approaches to Hydrographic, Ocean and Coastal Mapping Data Processing with Emphasis on Increasing Efficiency While Understanding, Quantifying, and Reducing Uncertainty</b> .....	<b>66</b>
Improved Bathymetric Processing .....	66
Improved Processing for Phase-Measuring Bathymetric Sonars.....	72
Evaluation of Uncertainty in Bathymetry, Navigation and Shoreline Data from Photogrammetry or Satellite Imagery .....	78
Improved Backscatter Processing .....	81
Data Management.....	87

■ <b>THEME 3 - Developing Tools and Approaches for the Adaptation of Hydrographic, Coastal and Ocean Mapping Technologies for the Mapping of Benthic Habitat and Exploring the Broad Potential of Mapping Features in the Water Column</b> .....	<b>85</b>
Habitat Mapping.....	85
Lidar, Hyperspectral, and Optical Approaches to Habitat Characterization .....	92
Instruments to Ground Truth Sonar, ALB, Hyperspectral and Other Remotely Sensed Data .....	96
Water Column Mapping.....	98
■ <b>THEME 4 - Developing Tools, Protocols, Non-Standard Products, and Approaches that Support the Concept of “Map Once – Use Many Times,” i.e., Integrated Coastal and Ocean Mapping</b> .....	<b>102</b>
Backscatter from Hydrographic Vessels .....	102
Bathymetry from the NOAA FSVs.....	103
Tools for Optimizing Third Party Bathymetric Data .....	104
Use of ECS Data for Charting Purposes .....	105
■ <b>THEME 5 - New and Innovative Approaches for the 3D and 4D Visualization of Hydrographic and Ocean Mapping Data Sets, Including Better Representation of Uncertainty, and Complex Time- and Space-Varying Oceanographic, Biological and Geological Phenomena</b> .....	<b>106</b>
Interactive Exploration/Visual Analysis System for Complex Time-Dependent Flow and Other Models.....	106
Ecosystem Visualization Project .....	108
Marine Mammals and Open Tag.....	110
Flow Visualization .....	111
GeoCamera.....	112
Semi-Immersive Large Format Tiled Display.....	113
■ <b>THEME 6 - Developing Innovative Approaches and Concepts for the Electronic Chart of the Future and E-Navigation</b> .....	<b>114</b>
Evolutionary.....	114
Open Navigation Surface .....	115
Right Whale AIS Project .....	115
IHO Compliant Current and Tide Display .....	116
Risk Models for Hydrographic Resurvey Priority Determination and Real-Time Risk Prediction .....	116
Automated Approaches to Data Generalization for Chart Production .....	117
Revolutionary .....	118
Local Notice to Mariners—Chart Update Mashup (CHuM) GeoCoastPilot.....	118
■ <b>THEME 7 - Being National Leaders in the Planning, Acquisition, Processing, Analysis and Interpretation of Bathymetric Data Collected in Support of a Potential Submission by the U.S. for an Extended Continental Shelf Under Article 76 of the United Nations Convention on the Law of the Sea</b> .....	<b>120</b>
2013 Law of the Sea Activities.....	121
Extended Use of ECS Data .....	122
<b>OUTREACH</b> .....	<b>124</b>
<b>PARTNERSHIPS AND ANCILLARY PROGRAMS</b> .....	<b>130</b>
<b>APPENDIX A: GRADUATE DEGREES IN OCEAN MAPPING</b> .....	<b>131</b>
<b>APPENDIX B: FIELD PROGRAMS</b> .....	<b>136</b>
<b>APPENDIX C: OTHER FUNDING</b> .....	<b>139</b>
<b>APPENDIX D: PUBLICATIONS</b> .....	<b>140</b>
<b>APPENDIX E: TECHNICAL PRESENTATIONS AND SEMINARS</b> .....	<b>144</b>
<b>APPENDIX F: NOAA SHIP RAINIER KONGSBERG MARITIME EM710 MULTIBEAM ECHOSOUNDER</b> .....	<b>147</b>



The NOAA-UNH Joint Hydrographic Center (JHC/CCOM) was founded fourteen years ago with the objective of developing tools and offering training that would help NOAA and others meet the challenges posed by the rapid transition from the sparse measurements of depth offered by traditional sounding techniques (lead lines and single-beam sonars) to the massive amounts of data collected by the new generation of multibeam echosounders and to promote the development of new ocean mapping technologies. Since its inception, the Center has been funded through Cooperative Agreements with NOAA. The most recent of these, the result of a national competition, funded the Center for the period of 1 July 2010 until December 2015.

Over the years, the focus of research at the Center has expanded, and now encompasses a broad range of ocean mapping applications. An initial goal of the Center was to find ways to process the massive amounts of data coming from multibeam and sidescan sonar systems at rates commensurate with data collection; that is, to make the data ready for chart production as rapidly as the data could be collected. We have made great progress in attaining and, now, far surpassing this goal and, while we continue to focus our efforts on data processing in support of safe navigation, our attention has also turned to the opportunities provided by this huge flow of information to create a wide range of products that meet needs beyond safe navigation (e.g., marine habitat assessments, gas-seep detection, fisheries management, and national security). Our approach to extracting “value added” from data collected in support of safe navigation was formalized with the enactment on the 30th of March 2009 of the Ocean and Coastal Mapping Integration Act—and our establishment of an Integrated Ocean and Coastal Mapping (IOCM) Processing Center at UNH to support NOAA and others in delivering the required products of this new legislation. In 2010, the concept of IOCM was demonstrated when we were able to quickly and successfully apply tools and techniques developed for hydrographic and fisheries applications to the Deep-water Horizon oil spill crisis.

In the relatively short period of time since our establishment, we have built a vibrant Center with an international reputation as the place, “where the cutting edge of hydrography is now located” (Adam Kerr, Past Director of the International Hydrographic Organization in *Hydro International*). In the words of Pat Sanders, President of HYPACK Inc., a leading provider of hydrographic software to governments and the private sector:

*“JHC/CCOM has been THE WORLD LEADER in developing new processing techniques for hydrographic data. JHC/CCOM has also shown that they can quickly push new developments out into the marketplace, making both government and private survey projects more efficient and cost effective.”*

Since our inception, we have worked on the development of automated and statistically robust approaches to multibeam-sonar data processing. These efforts came to fruition when our automated processing algorithm (CUBE) and our new database approach, i.e., The Navigation Surface, were, after careful verification and evaluation, accepted by NOAA, the Naval Oceanographic Office and other hydrographic agencies, as part of their standard processing protocols. Today, almost every hydrographic software manufacturer has, or is, incorporating these approaches into their products. It is not an overstatement to say that these techniques are revolutionizing the way NOAA and others in the ocean mapping community are doing hydrography. These techniques can reduce data processing time by a factor of 30 to 70 and provide a quantification of uncertainty that has never before been achievable in hydrographic data. The result: “gained efficiency, reduced costs, improved data quality and consistency, and the ability to put products in the hands of our customers faster.” (Capt. Roger Parsons, former NOAA IOCM Coordinator and Director of NOAA’s Office of Coast Survey).

The acceptance of CUBE and the Navigation Surface represents a paradigm shift for the hydrographic community—from dealing with individual soundings (reasonable in a world of lead line and single-beam sonar measurements) to the acceptance of gridded depth estimates (with associated uncertainty values) as a starting point for hydrographic products. The research needed to support this paradigm shift has been a focus of the Center since its inception and to now see it being accepted is truly rewarding. It is also indicative of the role that the Center has played and will continue to play, in establishing new directions in hydrography and ocean mapping.

Another long-term theme of our research efforts has been our desire to extract information beyond depth (bathymetry) from the mapping systems used by NOAA and others. We have made significant progress in developing a simple-to-use tool (GeoCoder) for generating a sidescan-sonar or backscatter “mosaic”—a critical first step in analyzing the seafloor character. There has been tremendous interest in this software throughout NOAA and many of our industrial partners have now incorporated GeoCoder into their software products.

Like CUBE's role in bathymetric processing, GeoCoder is becoming the standard approach to backscatter processing. An email from a member of the Biogeography Team of NOAA's Center for Coastal Monitoring and Assessment said:

*"We are so pleased with GeoCoder! We jumped in with both feet and made some impressive mosaics. Thanks so much for all the support."*

Beyond GeoCoder, our efforts to support the IOCM concept of "map once, use many times" are also coming to fruition. In 2011, software developed by Center researchers was installed on several NOAA fisheries vessels equipped with Simrad ME70 fisheries multibeam echosounders. These sonars were originally designed for mapping pelagic fish schools but, using our software, the sonars are now being used for multiple seabed mapping purposes. For example, data collected on the *Oscar Dyson* during an acoustic-trawl survey for walleye pollock was opportunistically processed for seabed characterization in support of essential fish habitat (EFH) and also in support of safety of navigation, including submission for charts and identification of a Danger to Navigation. In 2012, seafloor mapping data from the ME70 was used by fisheries scientists to identify optimal sites for fish-traps during a red snapper survey. Scientists aboard the ship said that the seafloor data provided by Center software was "invaluable in helping accomplish our trapping objectives on this trip."

In 2013, tools we developed for producing bathymetry and other products from fisheries sonars are being installed on NOAA fisheries vessels and operators are being trained for their regular use. All of these (CUBE,

GeoCoder, and our fisheries sonar tools) are tangible examples of our (and NOAA's) goal of bringing our research efforts to operational practice.

As technology evolves, the tools needed to process the data and the range of applications that the data can address will also change. We are beginning to explore the use of Autonomous Underwater Vehicles (AUVs) as platforms for hydrographic and other mapping surveys and are looking closely at the capabilities and limitations of Airborne Laser Bathymetry (lidar) in shallow-water coastal mapping applications. To further address the critical very shallow-water regimes, we are also looking at the use of personal watercraft and aerial imagery as tools to measure bathymetry in that difficult zone between zero and ten meters water depth. The Center is also bringing together many of the tools we have developed to explore what the "Chart of the Future" may look like.

In the last few years, a new generation of multibeam sonars has been developed (in part as a result of research done at the Center) with the capability of mapping targets in the water-column as well as the seafloor. We have been developing visualization tools that allow this water-column data to be viewed in 3D in real-time. Although the ability to map 3D targets in a wide swath around a survey vessel has obvious applications in terms of fisheries targets (and we are working with fisheries scientists to exploit these capabilities), it also allows careful identification of shallow hazards in the water-column and may obviate the need for wire sweeps or diver examinations to verify least depths in hydrographic surveys. These water-column mapping

tools were a key component to our efforts to map submerged oil and gas seeps and monitor the integrity of the Macondo 252 wellhead as part of the national response effort to the Deepwater Horizon oil spill and continue to be a focus of national and international interest as a means to help quantify the flux of methane into the ocean and atmosphere.

The value of our visualization, water-column mapping, and Chart of the Future capabilities have also been demonstrated by our work with Stellwagen National Marine Sanctuary aimed at facilitating an adaptive approach to reducing the risk of collisions between ships and endangered North American right whales in the sanctuary. We have developed 4D (space and time) visualization tools to



Figure ES-1. NOAA Ship *Ferdinand R. Hassler* (S-250) at the pier in New Castle, NH. Photo by Mike Ross, UNH Photo Services.

monitor the underwater behavior of whales as well as to notify vessels of the presence of whales in the shipping lanes and to monitor and analyze vessel traffic patterns. Describing our interaction with this project, Dan Basta, Director of the Office of National Marine Sanctuaries, said:

*"...I am taking this opportunity to thank you for the unsurpassed support and technical expertise that the University of New Hampshire's Center for Coastal and Ocean Mapping/NOAA-UNH Joint Hydrographic Center provides NOAA's Office of National Marine Sanctuaries. Our most recent collaboration to produce the innovative marine conservation tool WhaleAlert is a prime example of the important on-going relationship between our organizations. WhaleAlert is a software program that displays all mariner-relevant right whale conservation measures on NOAA nautical charts via iPad and iPhone devices. The North American right whale is one of the world's most endangered large animals and its protection is a major NOAA and ONMS responsibility. The creation of WhaleAlert is a major accomplishment as NOAA works to reduce the risk of collision between commercial ships and whales, a major cause of whale mortality.*

*"...WhaleAlert brings ONMS and NOAA into the 21st century of marine conservation. Its development has only been possible because of the vision, technical expertise, and cooperative spirit that exist at CCOM/JHC and the synergies that such an atmosphere creates. CCOM/JHC represents the best of science and engineering and I look forward to continuing our highly productive relationship."*

Statements from senior NOAA managers and the actions of other hydrographic agencies and the industrial sector provide clear evidence that we are making a real contribution to NOAA and the international community. We will certainly not stop there. CUBE, The Navigation Surface, GeoCoder and The Chart of the Future offer frameworks upon which new innovations are being built and new efficiencies gained. Additionally, these achievements provide a starting point for the delivery of a range of hydrographic and non-hydrographic mapping products that set the scene for many future research efforts.

## Highlights from Our 2013 Program

Our efforts in 2013 represent the continued growth and refinement of successful ongoing research programs combined with the evolution of new programs developed within the seven research themes prescribed by the Cooperative Agreement with NOAA (Sensors, Processing, Habitat and Water Column Mapping, IOCM, Visualization, Chart of the Future, and Law of the Sea). Given severe budget cuts in 2013, efforts on several initiatives (Habitat Mapping, Chart of the Future and, particularly, Law of the Sea) had to be reduced relative to previous years, but progress was still made in each of the themes. Additionally in 2013, some of our efforts were diverted to research and data processing associated with a response to Hurricane Sandy. These efforts, while drawing on research conducted under this grant, are funded by a separate grant.

As our research progresses and evolves, the initially clear boundaries between the research themes have become more and more blurred. For example, from an initial focus on sonar sensors we have expanded our efforts to include lidar and satellite imagery. Our data-processing efforts are evolving into habitat characterization, mid-water mapping and IOCM efforts. The data-fusion and visualization projects are also blending with our seafloor characterization, habitat and Chart of the Future efforts as we begin to define new sets of "non-traditional" products. This is a natural (and desirable) evolution that slowly changes the nature of the programs and the thrust of our efforts. Although the boundaries between the themes are diffuse and often somewhat arbitrary, our Progress Report maintains the thematic divisions; the highlights outlined below offer only a glimpse at the Center's activities, but hopefully provide key examples of this year's efforts.

One of the highlights of 2013 was the arrival of the newest addition to the NOAA hydrographic survey vessel fleet, the NOAA Ship *Ferdinand R. Hassler* (S-250), to its new homeport at the UNH pier facilities in New Castle, NH. The *Hassler* is a coastal mapping vessel utilizing the Small Waterplane Area Twin Hull (SWATH) design. The homeporting of the *Hassler* in proximity to the Center will enable researchers at the Center to work much more closely with the NOAA team on the *Hassler*, greatly increasing our ability to understand the survey challenges facing NOAA hydrographers and the efficiency with which we can turn our research into real-world solutions. Additionally, the proximity of the NOAA crew to the lab will allow ongoing interactions, including the easy participation of the *Hassler* crew in workshops, seminars and classes at the University. In celebration of the arrival of the *Hassler*, the University hosted a well-attended welcoming ceremony with State, Federal and University officials as well as many members of the local community (Figure ES-1).



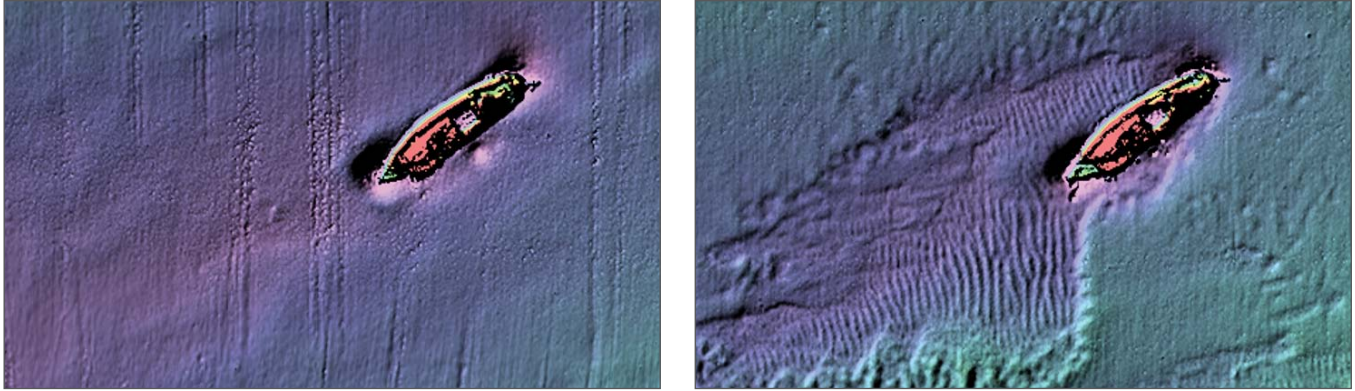

Figure ES-2. Bathymetry before (left) and after (right) Superstorm Sandy on the seafloor of the Redbird Reef site off Delaware.

## Sensors

We continue to work closely with NOAA and the manufacturers of sonar and lidar systems to better understand and calibrate the behavior of the sensors used to make the hydrographic and other measurements for ocean mapping. Many of these take advantage of our unique acoustic test tank, the largest of its kind in New England and now equipped with state-of-the-art test and calibration facilities. Among the highlights of this year's efforts are the calibration of two Reson 7125 multibeam echosounders (MBES) from the NOAA Ship *Fairweather* and the return of those sonars to the fleet so that we can begin to inter-calibrate the many 7125s that NOAA uses and better understand the backscatter collected with these systems. Understanding that it will be impossible to bring all of NOAA's sonars into the calibration facility, we are developing a procedure for calibrating these sonars in the field. Additionally, we calibrated and explored the capabilities of several other sonars of potential interest to NOAA and others including Teledyne's MB-1, ENL's WASSP, Simrad's EK-60 and EK-80 WideBand Transceiver, and Klein's Hydrochart 5000 Phase Measuring Bathymetric Sonar.

The expertise of the Center with respect to MBES has been recognized through a number of requests for Center personnel to participate in field acceptance trials of newly installed sonars in the fleet. The Center has taken a lead in the establishment (through funding from the National Science Foundation) of a national Multibeam Advisory Committee (MAC) with the goal of ensuring that consistently high-quality multibeam data are collected across the U.S. Academic Research Fleet and other vessels. The experience gained from our MAC activities will be fed directly back into our support of NOAA mission-related research and education. Part of this effort is the development and dissemination of best-practice documentation and quality assurance and performance prediction software that have already been introduced into the NOAA fleet. In 2013, the

MAC team assisted in sonar installation and acceptance trials on the Schmidt Ocean Institute's R/V *Falkor* and the Ocean Exploration Trust's E/V *Nautilus*. They also visited the UNOLS vessels *Melville* and *Kilo Moana*, assessing and reporting on the performance of their sonar systems. Center staff also made visits to, or consulted with staff on the NOAA vessels *Rainier*, *Ron Brown*, and *Thomas Jefferson* to help troubleshoot problems associated with the sonar systems on these vessels.

Our concern about sensors extends to the instruments that collect the critical ancillary data needed for producing accurate bathymetric data. Unquestionably, one of the greatest sources of uncertainty in our bathymetric data is our inability to capture the spatial and temporal changes of the sound-speed structure of the water column (needed to convert the echosounder measurements to accurate depths). To address this issue, NOAA has adopted "Moving Vessel Profilers" (MVPs) that allow closely-spaced sound-speed profiles to be collected rapidly while the vessel is underway. One of the key questions facing those using these systems is the profiling interval needed to capture the true variability of the water column. Too few profiles can lead to poor data quality whereas too many can lead to degradation and possibly the loss of the instrument. To address this problem, graduate student and NOAA Physical Scientist Matt Wilson and Center researcher Jonathan Beaudoin developed the "CastTime" algorithm that determines the optimal spacing for MVP casts and automatically controls the profiler. In 2013, plans were developed to implement CastTime as an operational tool in the NOAA fleet and test implementations took place on the NOAA Ships *Thomas Jefferson* and *Rainier*. This example epitomizes the role that the Center can play in support of NOAA. A NOAA student arrives at the Center with a specific NOAA problem. She or he works with our faculty and staff to come up

with a solution to the problem and then returns to the fleet with a solution and implementation.

In our evaluation of new sensors and their applicability to hydrographic problems, we have, through collaboration with Prof. Art Trembanis at the University of Delaware, been exploring the viability of using Autonomous Underwater Vehicles (AUVs) as a platform for hydrographic measurements. This year, we have continued to take advantage of an ONR-funded “Bedforms” project where numerous repeat deployments of the Gavia AUV have allowed us to explore the hydrographic and positional accuracy of AUV-collected data as well as directly address the question of the impact of Super Storm Sandy. The focus of the work is the “Redbird Reef” site off Delaware where hundreds of subway cars and other man-made objects have been submerged to form an artificial reef. Six bathymetric surveys using a Geoswath phase-measuring bathymetric sonar deployed from the AUV and a surface ship-mounted Reson 7125 MBES were completed over the site (three in 2012, three in 2013), including one survey three days before and one survey seven days after Super Storm Sandy (Figure ES-2). The combination of both surface ship and AUV-navigated surveys afforded an opportunity to compare survey quality and to consider alternative methods for the processing of AUV collected data. Comparisons between AUV-based and surface ship-based bathymetric surveys revealed that, in 27 m of water, it may be possible to meet the IHO Special Order 2-sigma depth uncertainty requirement with the AUV if it’s carefully positioned and the data is very carefully processed.

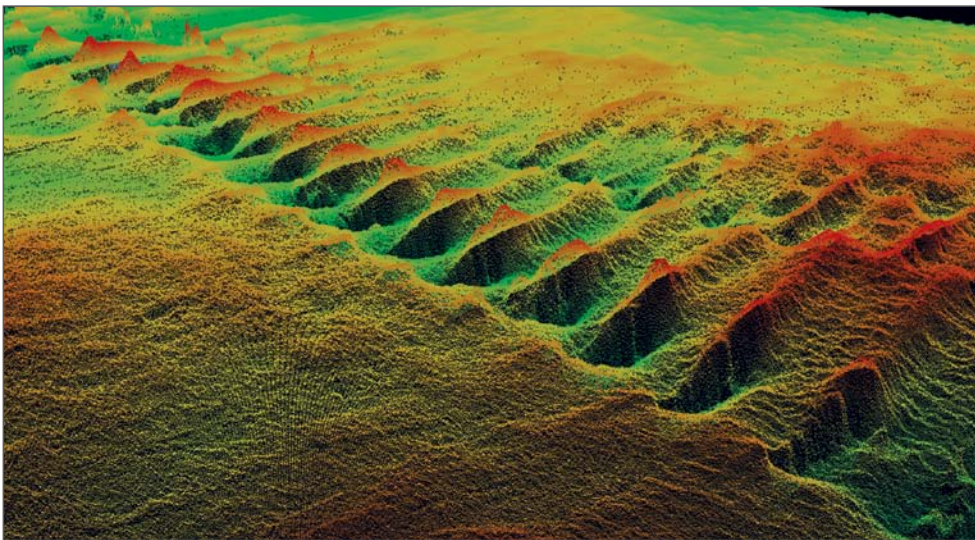

Figure ES-3. Visualization of an early CHRT hierarchical surface in CARIS software (in this case of bridge supports). The co-development model encourages early adoption of software and synergies between developers and testers that can benefit the whole community and ensure correct transmission of algorithms from research to operations. (Data courtesy of Bill Lamey, CARIS, and Jack Riley, NOAA.)

## Processing

In concert with our efforts focused on understanding the behavior and limitations of the sensors we use, we are developing a suite of processing tools aimed at improving the efficiency of producing the end products we desire but, just as importantly, are also aimed at quantifying (and reducing if possible) the uncertainty associated with the measurements we make. These efforts, led by Brian Calder, are now directed on further development of the next generation of the CUBE approach to bathymetric data processing—CHRT (CUBE with Hierarchical Resolution Techniques) algorithm.

CHRT is a software architecture for robust bathymetric data processing that takes the core estimator from the CUBE algorithm and embeds it in a system that allows for variable resolution of data representation that is data adaptive, meaning that the density of data collected is reflected in the resolution of the estimates of depth. This year’s efforts have focused on four areas: a fully-distributed version of the algorithm; transition to practice of the serial and single-processor parallel versions of the algorithm in conjunction with NOAA and Center Industrial Partners; improvements to the core algorithm to support interactive data analysis in implementation; and extensions to the algorithm to allow first-order slope correction based on preliminary robust estimates of surface parameters. Most importantly, the co-development model developed by the Center appears to be working and progress has been made in the implementation of CHRT with our Industrial Partners, assuring that the algorithms will be available for use by NOAA and the broader community in a timely manner (Figure ES-3).

Our efforts to understand uncertainty and improve data-processing flow have also expanded to an alternative type of swath-mapping sonar—one that uses multiple rows of offset arrays to determine depth through the measurement of phase differences. These sonars can offer wider swath coverage (and thus increase survey efficiency) but there are a number of outstanding questions about the quality of the bathy-



metric data they produce and the difficulties associated with processing. To address these issues, Val Schmidt and others have been developing new approaches to phase-measuring bathymetric sonar (PMBS) processing (“Most Probable Angle” algorithm) and, with this, have been quantifying the uncertainty associated with these measurements. This year, comparisons of PMBS systems at the Redbird Reef site (see above) and field trials with a Klein Hydrochart 5000 PMBS have provided important new insights into the hydrographic capabilities of PMBS.

As discussed earlier, it is becoming increasingly apparent that the largest contributor to uncertainty in our collection of seafloor mapping data is our inability to fully capture the spatial and temporal variability of the speed of sound in the water masses in which we work. In addition to the CastTime approach to optimizing moving vessel profiler casts, Jonathan Beaudoin is looking at the use of historical or model data to help in those areas where sufficient real-time data does not exist and to streamline the process of entering sound-speed data into our sonar systems. As part of these efforts, Beaudoin has developed an “SVP Editor” that allows for the rapid and automated input of sound-speed profiles into MBES systems as well as interactive graphical data editing for removal of outliers and/or the addition of points for vertical extrapolation. In 2013, the SVP Editor was integrated with the software used on NOAA vessels (QINYSy, Hypack, Caris HIPS, and PDS2000) and the SVP Editor was installed on NOAA Ship *Rainier* along with CastTime as an additional tool to improve real-time refraction corrections with *Rainier’s* EM710.

The SVP Editor also offers the user the ability to run the software in “Server” mode whereby a synthetic sound-speed profile is delivered to the echosounder over the network based on oceanographic models such as the World Ocean Atlas (WOA) or the Real-Time Ocean Forecast System (RTOFS). The SVP Editor uses position information from the sonar to establish the date and position of the vessel that are then used to form a query for the oceanographic model of choice and to establish estimates of the temperature and salinity profiles for the desired location. A sound-speed profile is constructed from these and is delivered to the MBES. This can be done continuously while in transit, enabling opportunistic underway mapping such that echosounding data gathered in the absence of the directly observed sound-speed data has at least a rudimentary refraction correction applied with no operator intervention required. In both use-case scenarios, an important additional functionality of the SVP Editor is to provide the hydrographer with the ability to preview the effects

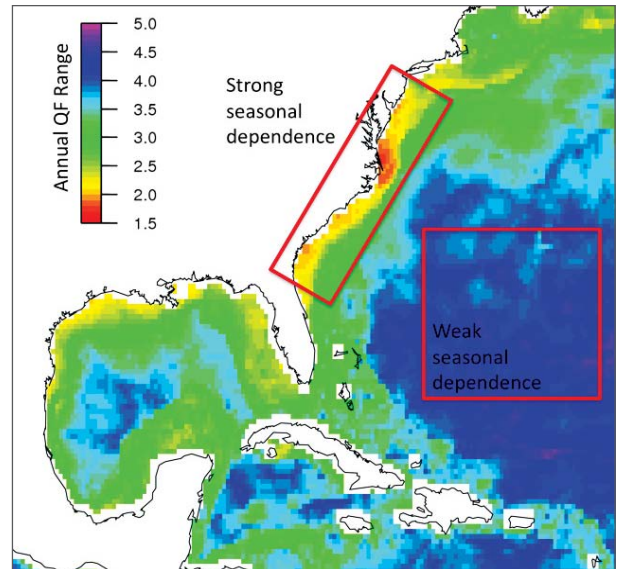

Figure ES-4. Annual range of Quality Factor (QF) based on WOA2001 (1/4°) ray tracing monthly analyses. Areas with strong seasonal effects exhibit a large difference between the highest and lowest QF over the course of the year, e.g., the inner shelf along the eastern seaboard. The WOA predicts weak seasonal dependence in the open ocean.

of applying the new sound-speed profile to data in real-time prior to delivery to the sounder in order to see the effect of the new profile. This allows for an important verification step in which the operator can correct or adjust the profile to minimize refraction residuals in real-time. In 2013, variations on this approach were implemented to allow fisheries sonar data from the NOAA Ship *Pisces* and single-beam sonar data from the USCG vessel *Hickory* to be used to update the charts in areas of very sparse data.

Carrying the approach of using oceanographic models in aid of seafloor mapping one step further, Beaudoin continues to work on developing tools to help better understand the “underwater weather” that can severely limit the achievable accuracies of echo sounding data, particularly with wide swath MBES. The result of this effort is something akin to a weather map for hydrographers—the basic idea is that oceanographic models of temperature and salinity can provide us with an estimate of where spatial variability in the water column can be problematic. With high-resolution models like RTOFS, it is now possible to compute forecasts with high spatial resolution and fidelity. The approach has proven invaluable for planning cruises and in avoiding times or areas of high oceanographic variability. In 2013, efforts were focused on incorporating well-established sonar quality factors into the model so that the output is presented in a hydrographically recognized metric representing the quality of the bathymetric data collected (Figure ES-4).



In concert with our efforts to improve the processing of bathymetric data, we are also focusing significant effort on trying to improve approaches to processing backscatter (amplitude) data that are collected simultaneously with bathymetric data but have traditionally not been used by hydrographic agencies. These data are becoming more and more important as we recognize the potential for seafloor mapping to provide quantitative information about seafloor type that can be used for habitat studies, engineering evaluations, and many other applications. Essential to this effort is understanding the uncertainty associated with the measurement of acoustic backscatter from the seafloor. The fundamental question is: when we see a difference in the backscatter displayed in a sonar mosaic, does this difference truly represent a change in seafloor characteristics or can it be the result of changes in instrument behavior or the ocean environment? The focus of our effort in addressing this difficult question is a new project we call the New Castle Backscatter Experiment (NEBEX). This project, which involves close collaboration with NOAA's Glen Rice and NOAA graduate student Briana Welton, brings together several different existing lab efforts: Mashkoor Malik's Ph.D. thesis work; Carlo Lanzoni's work toward an absolute backscatter calibration for MBES; Sam Greenaway's and Glen Rice's efforts toward field procedures for proper backscatter data collection; backscatter mosaicing (Geo-Coder); backscatter inversion; and backscatter ground truth (e.g., optical imagery, bottom sampling, high accuracy positioning). Associated with this effort is our work calibrating individual sonars and addressing concerns raised by our NOAA partners about specific systems they are using in the field. Tools and protocols that were developed as part of this effort (e.g., a backscatter "saturation monitor" developed by Glen Rice) and designed to ensure that high-quality backscatter data are collected have already been implemented in the NOAA hydrographic fleet.

Fundamental to the NEWBEX experiment is a field campaign designed to establish a "standard backscatter line" conveniently located near the UNH pier in New Castle, NH with known seafloor backscatter (at 200 kHz), where "known" equates to an empirically derived absolute seabed backscattering cross section with an associated uncertainty. Throughout 2013, data along the standard line was (and still is being) collected with a calibrated split-beam echosounder at a launch angle of 45° on a weekly basis. The standard line, chosen in consultation with NOAA OCS in anticipation of the arrival of the *Ferdinand R. Hassler*, begins in a gravel area on the north end, traverses a large sand wave field, and ends in an area of clean gravel. At regularly spaced intervals along the line, the data have been averaged to provide an estimate of the mean backscatter level. The variability in the mean backscatter level over an initial ten-week period of the study was remarkably small, with a total spread that is typically less than 2 dB (Figures ES-5). This coming year, we will be analyzing the backscatter trends over the entire time frame, and will also attempt to observe any changes resulting from

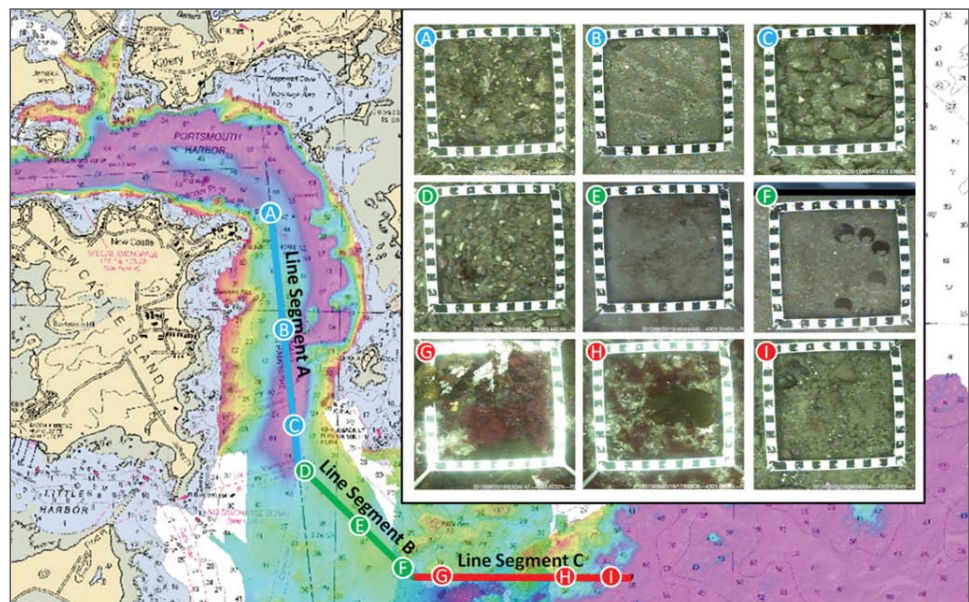

Figure ES-5a. The NEWBEX standard line and field campaign locations. Images from a subset of groundtruth sites are shown.

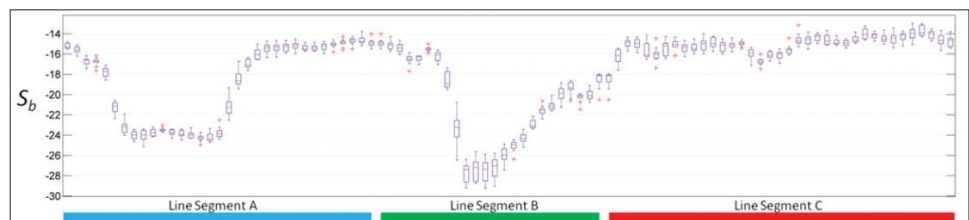

Figure ES-5b. A boxplot describing the distribution of average seabed backscatter,  $S_b$ , collected weekly over ten weeks. The boxes describe the boundaries of the 25<sup>th</sup> and 75<sup>th</sup> percentiles, the central mark is the median, and the whiskers extend to the most extreme data points not considered to be outliers.

large storm events including a storm event that took place at the end of December.

Our processing efforts have extended beyond acoustic systems to also look at developing better ways to extract information about bathymetry, navigation and shorelines from lidar, photogrammetry and satellite imagery. Included amongst these efforts is our collaboration with scientists from the National Geodetic Service (NGS) looking at the uncertainty associated with photogrammetric and lidar-based shoreline estimates. This work, led by Chris Parrish, has produced an “EO TPU Tool” and a set of standard operating procedures (SOP) for production use of directly-georeferenced aerial imagery in NGS’s Coastal Mapping Program (CMP). In tests of this approach in a complex region of “Downeast” Maine in 2013, the estimated shoreline TPU was found to be well within the IHO S-44 standards for uncertainty in positioning the coastline using both tide-coordinated and non-tide-coordinated imagery. It is anticipated that this work will assist NGS in generating accuracy metadata for photogrammetrically-mapped shorelines, as well as in project planning and decision making. An important characteristic of the TPU model developed in this work is that it is general enough to be extended to other coastal regions and settings.

Shoreline estimation techniques developed at the Center have also been used as part of the Center’s effort to support post-Hurricane Sandy relief activities. Lindsay McKenna, working with Chris Parrish, Brian Calder and others, has developed a work flow for establishing pre and post-storm shoreline and erosion maps along the New Jersey coast using EAARL-B topo-bathy lidar collected by the USGS (Figure ES-6).

Finally, a new and exciting start this year has been our evaluation of the potential for using satellite imagery as a means to extract shallow water bathymetric information in regions where vessel access is limited. Shachak Pe’eri has led a Center effort to develop approaches for deriving bathymetry from imagery and for assessing the value of these data for change analysis, habitat mapping, and hydrographic survey planning. Initial efforts focused on data from tropical regions with relatively clear waters (e.g., Belize). The most appropriate

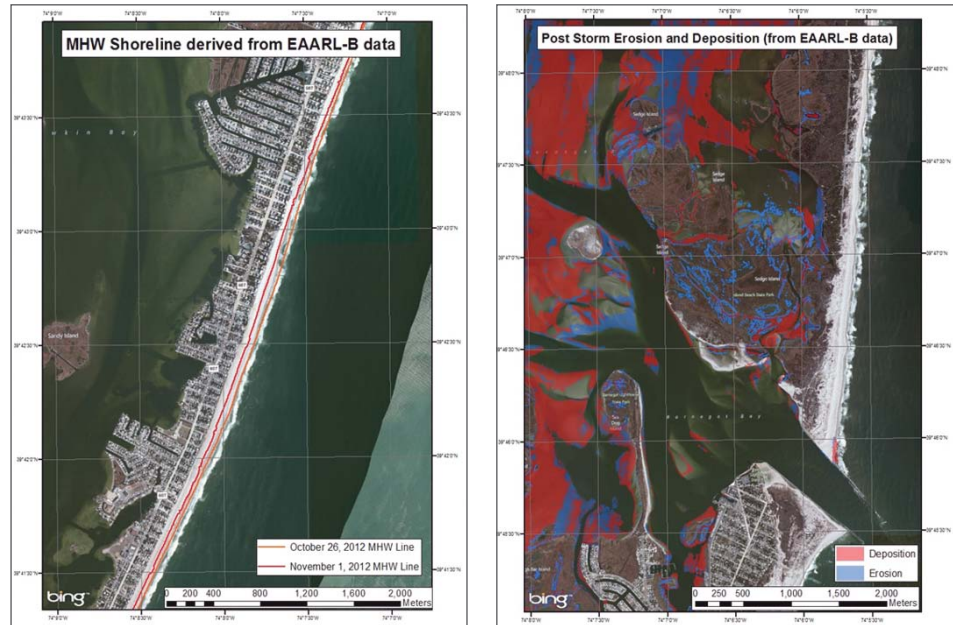

Figure ES-6. Pre- and Post-Hurricane Sandy shoreline (referenced to MHW) along 5 km of Long Beach Island, NJ (left). Areas of erosion and deposition in Barnegat Bay caused by Hurricane Sandy (right).

algorithms were chosen and the accuracy of the results modeled using a Monte Carlo simulation and validated against reference datasets.

In 2013, these techniques were applied to two regions, Haiti and offshore of the North Slope of Alaska, where bathymetric data is very sparse. In response to the Haiti Earthquake disaster, NOAA and other hydrographic offices around the world have provided support to SHOH (Service Hydrographique et Océanographique de Haiti) by training SHOH personnel, surveying key areas around Haiti, and updating the charts. As part of the 2013 NOAA effort to support SHOH, the satellite-derived bathymetry (SDB) was used and proved useful in identifying shoal features not surveyed in 2010. A more challenging application was the attempt to extract bathymetry in remote regions where seasonal runoff can create very turbid waters (Figure ES-7). To accommodate this, the SDB procedure was further developed to compile multiple satellite images and use only the areas that were identified “clear” by comparison (i.e., minimum water clarity change between two satellite images). This work, done in collaboration with NOAA’s Marine Charting Division, is now being evaluated by NOAA’s Hydrographic Survey Division (HSD) as a potential aid for survey planning. Along with estimates of satellite-derived depth, Chris Parrish has developed a total propagated uncertainty (TPU) model for satellite-derived bathymetry grids, an essential component for understanding the usefulness of these data for future applications.



## Habitat and Water Column Mapping

Our efforts to understand and calibrate the acoustic and optical sensors we use (Sensors theme) and to develop software to process the data they produce in an efficient manner while minimizing and quantifying the uncertainty associated with the measurements (Processing theme), are directed to producing products that not only support safe navigation but that can also provide information critical to fisheries management and other environmental and engineering problems. These efforts have focused on understanding and interpreting the backscatter (both from the seafloor and more recently with the advent of a new generation of multi-beam sonars, in the water column) and generating tools to use this information to provide key information useful to marine managers. Our efforts in acoustic seafloor characterization have focused around the GeoCoder software package (designed to make fully corrected backscatter mosaics and calculate a number of backscatter statistics) and a constrained ARA (Angular Response Analysis) inversion that is designed to analyze the angular response of the backscatter as an approach to remote seafloor characterization. Although GeoCoder has been implemented by many of our Industrial Partners, many questions remain about the calibration of the sonars (e.g., the work described in the Sensor and Processing sections) and the inherent nature of the approaches used to segment and characterize seafloor properties. This year's efforts focused on rebuilding and restructuring the GeoCoder processing pipeline into software modules. These modules honor the algorithms implemented in the original GeoCoder framework but clear boundaries are set between the

various data-flow and processing stages so that researchers can investigate and potentially improve upon a single module without the overhead of maintaining the overall software framework or rebuilding (compiling) the entire application. Several "plug-in" modules have already been created that are enhancing the capabilities for specific sonars or applications.

As part of our IOCM activities (see IOCM theme), we are exploring means of extracting multiple data sets from a single sonar survey/system. To this end, Jodi Pirtle and Tom Weber collaborated with the NOAA Alaska Fisheries Science Center (AFSC) to map groundfish habitat in the Gulf of Alaska (GOA) using the Simrad ME70 multibeam echosounder (ME70) with the primary goal of distinguishing between trawlable and untrawlable areas of the seafloor. Several parameters (angular dependence and maximum average backscatter between 30-50°) have been shown to be good predictors of trawlability. This information will ultimately improve efforts to determine habitat-specific groundfish biomass and to identify regions likely to contain deep-water coral and sponge communities that may be considered Habitat Areas of Particular Concern (HAPCs). This research supports NOAA's efforts to identify and describe Essential Fish Habitat (EFH) for harvested species, and to improve fisheries stock assessment methods for locations and seafloor types that are not easily accessible.

We are also exploring approaches to identify bottom type from single-beam echo-sounder data in very shallow water environments. Initial studies in Great Bay

have revealed a promising relationship between maximum and total backscatter intensity, depth and fine-grained components of the sediment (Figure ES-8).

Along with our work using acoustic data to attempt to extract critical habitat data, we are also working on techniques to quantitatively analyze lidar, hyperspectral and optical imagery. This past year, we initiated a research project with Steve Rohmann of the NOAA Office of National Marine Sanctuaries (ONMS) to develop tools and workflows that will enable

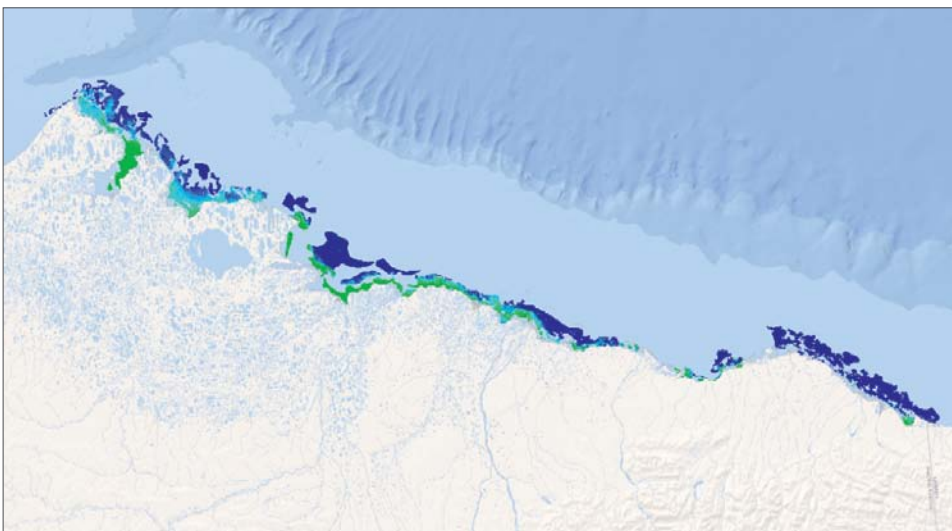

Figure ES-7. Shallow-water bathymetry derived offshore of the North Slope of Alaska using Landsat 7 (1999-2003) and Landsat 8 (2013) imagery.



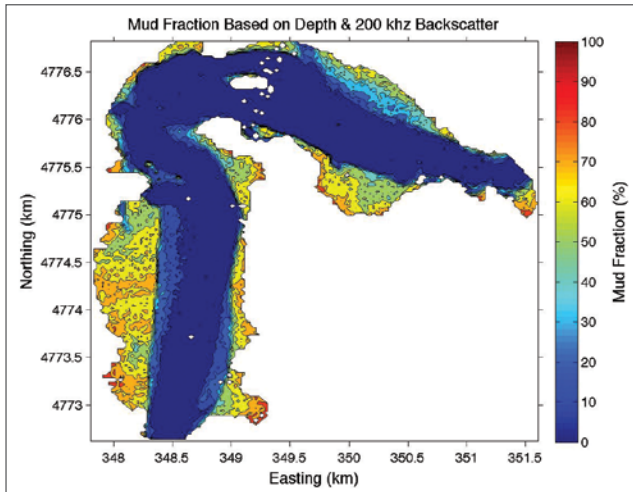

Figure ES-8. Distribution of mud fraction based on an average logarithmic model that includes depth,  $I_{tot}$ , and  $I_{max}$  and all sediment samples of Great Bay. These data provide a gross, first order approximation of the mud fraction in the surficial sediment of the Bay.

wide-scale use of remotely-sensed data for producing the required decision-making products without the need for expensive, specialized software and training or additional resources. The primary goal of this work is to build upon existing benthic habitat mapping procedures developed by the NOAA National Centers for Coastal Ocean Science (NCCOS) and overcome the challenges listed above. Initial efforts have focused on a  $\sim 1600 \text{ km}^2$  area in the Marquesas Keys, a chain of mangrove islands in the National Wildlife Refuge  $\sim 40 \text{ km}$  west of Key West, Florida. Progress to date on this project has included developing and documenting a new method for classification of geographic zones and the demonstration of the ability to remove seamline artifacts from lidar relative-reflectance data through processing applied in the Fourier domain using commercially-available image processing software (Figure ES-9).

As part of our lidar-based habitat mapping effort, we have also been looking at the behavior of the returned lidar waveform as an indicator of substrate type. An important finding of this work is that simple estimates of return pulse width alone were able to explain nearly 60% of vertical uncertainty variation in three salt marshes on Cape Cod,

Massachusetts (Figure ES-10). This variation in elevation uncertainty throughout a marsh is important to scientists and managers, since elevation differences of just a few centimeters can affect marsh migration and loss in response to sea level rise.

The efforts described above have focused on the seafloor. A new generation of multibeam sonars now has the ability to simultaneously map both the seafloor and the water column. Combining the ability to image the water column and the seafloor over wide swaths with high resolution offers great opportunities for new applications and increased survey efficiencies. The Center has been very active in developing tools to capture, analyze and visualize water-column data. These tools proved extremely valuable in our efforts to map the deep oil plume and monitor the integrity of the Macondo wellhead during the Deepwater Horizon (DWH) crisis (see the 2010 annual report for a full description of our activities related to Deepwater Horizon). Immediately following the Deepwater Horizon explosion and leak of the Macondo wellhead, we proposed the use of a 30 kHz multibeam sonar with water-column capability (a Kongsberg Maritime EM302) as a potential tool for mapping deep oil and gas spills and monitoring the wellhead for leaks. At the time of the spill, such a system was not available so we used fisheries sonars instead. In August and September of 2011, we finally had the opportunity to bring the EM302 multibeam echosounder onboard the NOAA Ship *Okeanos Explorer* to the Gulf of Mexico and test the water-column mapping capability for detecting and characterizing methane gas seeps. During this relatively short cruise (less than two weeks of active mapping), we mapped  $17,477 \text{ km}^2$  of the northern Gulf of Mexico

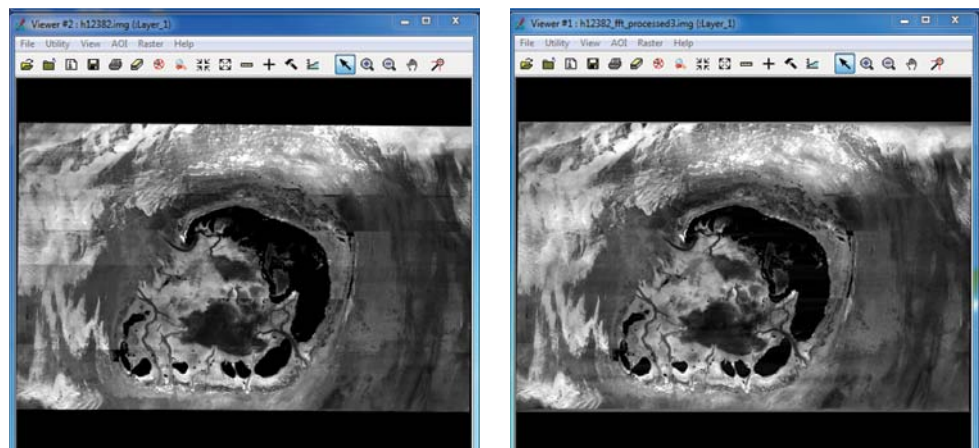

Figure ES-9. Results of the procedure to remove seamline artifacts in lidar relative reflectance data to facilitate coral reef habitat mapping. *Left*: input to Fourier-domain seamline removal procedure; *right*: output. It can be seen in the output image that many of the seamlines between adjacent flightlines (oriented east-west in the original image) have been greatly reduced or even eliminated.

making 573 seep observations. The results from this cruise demonstrated a new mid-water mapping technology for the *Okeanos Explorer*, and suggested that wide-scale mapping of seeps in the deep Gulf of Mexico—an objective that is important for both scientific and industry management perspectives—is viable.

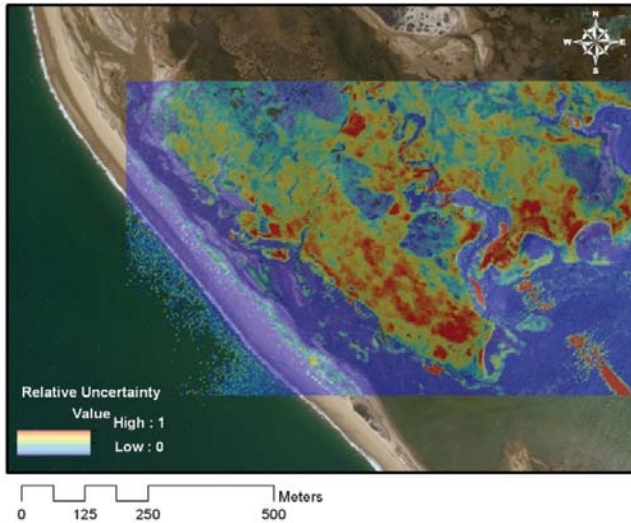

Figure ES-10. Relative uncertainty surface (arbitrary scale of 0-1 “relative uncertainty units”) for Moors marsh on Cape Cod, Massachusetts. If these types of surfaces can be provided as a standard output of future NOAA lidar projects, they may enable coastal managers to better understand the relative quality of elevation information across a marsh and assist in decision-making.

In 2013, we continued to analyze acoustic and ROV data collected with the *Okeanos Explorer* in our attempts to further our capabilities to detect, localize, and quantify gas seeps using split-beam and multi-beam echosounders. We exploit MBES data collected on the *Okeanos Explorer* for its wide field of view and accurate positioning capability in order to examine the locations, morphologies, and rise heights of the

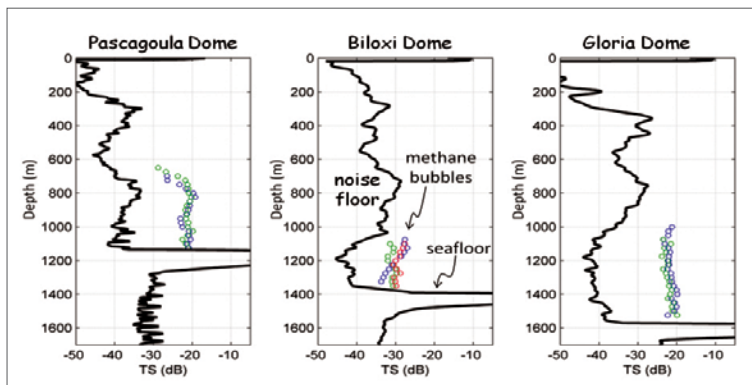

Figure ES-11. Split-beam echosounder measurements of gas plume target strength (colored circles) and background noise floor (black line) from seeps observed in the Gulf of Mexico.

plumes, and we exploit the split-beam echosounder data to provide calibrated measurements of seep target strength (Figure ES-11) that we can relate to gas flux if we know the bubble size distribution. A comparison of gas flux estimates made from acoustic and ROV direct capture methods has shown a remarkably close agreement (within 20%) from a seep on the Pascagoula Dome in the Gulf of Mexico, an encouraging result. These efforts have garnered great interest from the international community, particularly for their potential to help quantify the fate of methane in the ocean and the atmosphere.

## IOCM—Integrated Ocean and Coastal Mapping

A critical component of the Center’s 2010-2015 proposal was to establish an Integrated Ocean and Coastal Mapping Processing Center that would support NOAA’s new focused efforts on Integrated Coastal and Ocean Mapping. This new Center brings to fruition years of effort to demonstrate to the hydrographic community that the data collected in support of safe navigation may have tremendous value for other purposes. It is the tangible expression of a mantra we have long espoused, “map once – use many times.” The fundamental purpose of the new Center is to develop protocols for turning data collected for safety of navigation into useful products for fisheries habitat, environmental studies, archeological investigations and many other purposes and, conversely, to establish ways to ensure that data collected for non-hydrographic purposes (e.g., fisheries) will be useful for charting.

Representing the Office of Coast Survey at the Center, Glen Rice has been partnering with a number of Center members to design workflows for IOCM products and to provide a direct and knowledgeable interface with the NOAA fleet to ensure that we address high-priority issues and that the tools we develop are relevant for fleet use. In addition, Glen provides a direct link when specific operational difficulties arise in the field, allowing Center personnel to take part in designing an appropriate solution.

Epitomizing the IOCM concept have been our efforts aboard the NOAA fisheries vessel *Oscar Dyson*. In 2011 and 2012, while the *Dyson* was conducting routine acoustic trawl surveys, we were able to simultaneously extract bathymetry data (to date more than 452 square nautical miles of bathymetric data—along with uncertainty and calibrated backscatter derived from

the ME70—have been submitted for charting), and produce habitat maps of trawlable and untrawlable seafloor. One of the most exciting aspects of this effort was the discovery from the 2011 ME70 data of a previously uncharted shoal that led to a chart update and Danger to Navigation (DTON) warning. Thus, from a single fisheries sonar (ME-70) and a fisheries cruise dedicated to acoustic-trawl surveys, seafloor habitat data, bathymetric data for charting and a specific Danger to Navigation were all derived. All this from a sonar that was not purchased to map the seafloor.

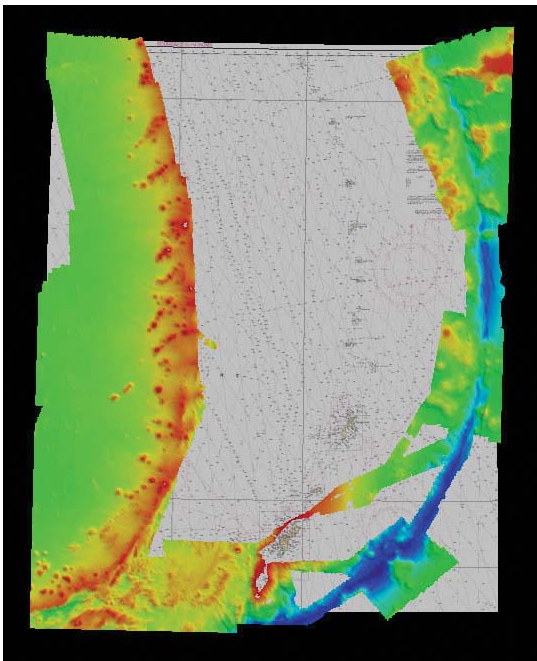

Figure ES-12. Data derived from UNH Extended Continental Shelf surveys being used to update W00270 NOAA Chart 81004.

This year, many of the IOCM-relevant tools and protocols developed at the Center are being put into practice in the fleet. Briana Welton and Glen Rice are developing and implementing calibration techniques and protocols to assure that the backscatter collected by NOAA hydrographic launches is comparable between launches and between surveys. Sarah Wolfskehl is using tools developed at the Center to produce qualified bathymetry and backscatter from fisheries sonars (ME70s) on NOAA Fisheries Service Vessels and efforts are underway to incorporate Center-developed techniques into the software packages in use by the fleet. Wolfskehl has also taken data collected for Law of the Sea purposes in the Marinas region and been able to use these data to update the chart (Figure ES-12).

We are indeed mapping once and using many times, and formalizing the workflows and protocols established with the goal of making these processes standard aboard NOAA vessels as part of the NOAA R2R program.

Our IOCM efforts have also extended to lidar data. Although many questions still remain about the viability of using Airborne Lidar Bathymetry (ALB) data for hydrographic purposes, there is no question that this approach provides the potential for the rapid collection of bathymetric data in very shallow water where traditional multibeam sonar surveys are least efficient. In an effort to better understand the applicability of third-party ALB data, the Center is working with NOAA to look at USACE and other outside ALB data sources and to compare the quality of the data collected by these systems as well as their standards and operations, to NOAA MBES data and to NOAA and international hydrographic survey standards.

## Visualization

We continue a very strong focus on the development of innovative approaches to data visualization and fusion and the application of these approaches to ocean mapping and other NOAA-related problems. Over the past few years, the visualization team, under the supervision of Lab Director Colin Ware, has produced a number of novel and innovative 3D and 4D visualization tools designed to address a range of ocean mapping applications. This year, Thomas Butkiewicz and Colin Ware continued to refine their advanced flow-visualization techniques that are critical for successful communication of the complex output of today's increasingly high-resolution oceanic and atmospheric forecast simulations. By applying well-founded perceptual theory to the design of visual representations, the contents of these models can be effectively illustrated without overwhelming the viewer. The integration of non-traditional interfaces, such as multi-touch displays and motion-capture, supports more efficient and flexible interactions that can overcome the challenges often encountered when attempting to navigate and manipulate within 3D environments. Finally, a number of new analytical tools allow the user to leverage the predictions of these simulations to support other research projects.

Virtual Test Tank 4D (VTT4D) is a new project that consolidates the various 3D and 4D flow visualization techniques that Butkiewicz and Ware have developed into a single application that is intended to be shared with other researchers and the public. It replicates many of the analytic abilities and model support found



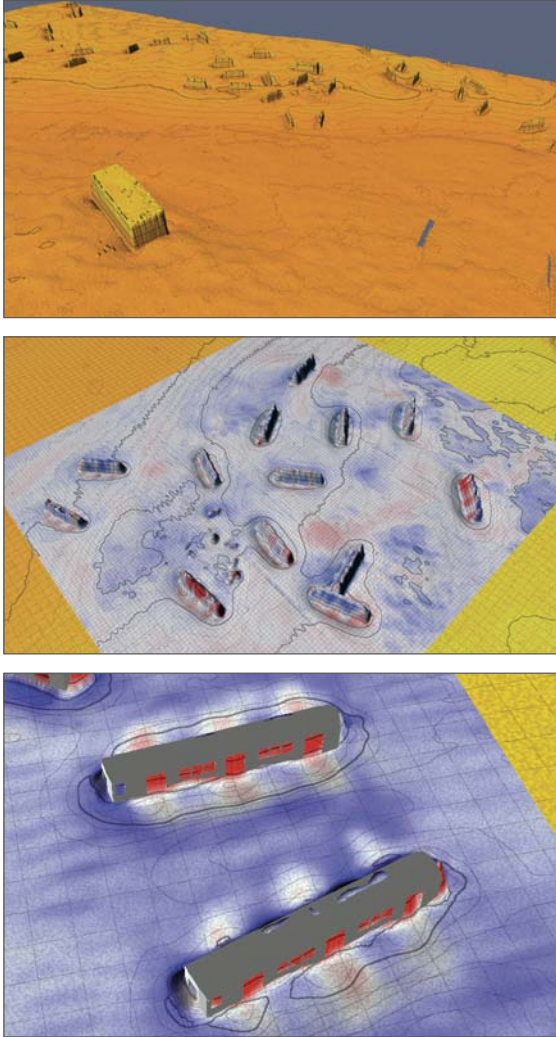

Figure ES-13. *Top*: static bathymetry of the Redbird artificial reef site as displayed in VTT4D. Rectangular objects are the bathymetric rendering of subway cars sunk to serve as artificial reefs. *Middle*: animated dynamic bathymetry at the Redbird reef site generated within VTT4D from five overlapping survey missions. Red areas experienced erosion, blue areas, deposition. *Bottom*: erosion (red surrounded by white) can be seen on either side of the subway cars in a pattern that is easily correlated to the locations of the doors as seen in the high resolution models of the cars. As the water flows through these openings it becomes turbulent and scours the seafloor.

in the previous flow visualization projects, but does so within an updated code base in an easy to distribute application. Its increased flexibility allows users outside the Center to utilize these 4D visualizations with their own data, without the need for custom programming on our end. It also implements many new features to support analysis and to aid presentation. An example is its use to visualize the dynamic seafloor changes after Super Storm Sandy in the Red Bird Reef site discussed

previously (Figure ES-13). Such visualizations may have important applications in determining the impact of events like Super Storm Sandy and the need for new survey work for chart updates. To support our visualization efforts and human-factor studies, the lab has also built a new immersive large-format display (Figure ES-14).

Closely related to our Chart of the Future Theme (see below), our visualization group is working with the International Hydrographic Organization to develop an S-100- (hydrographic data standard) compliant specification for the portrayal of tides and currents. Survey results of mariners overwhelmingly support the streamline-type portrayal developed by the Center (Figure ES-15). We are also looking at optimal ways to display 3D flow patterns using 3D tubes following streamlines with multiple cross sections or profiles.

Our visualization team has also been working with NOAA fisheries scientists to create visualizations to help interpret fisheries food web interactions and to interactively explore ecosystem based models of interactions between the key commercial species in the region (Figure ES-16). These tools can be used by NOAA fisheries and fishery management councils to make better-informed decisions relating to tasks such as setting fishing quotas. It will allow for long-term impacts (as modeled) of changes in policy to be easily seen and understood, and to be presented to various stakeholders. Our efforts in visualizing the submerged behavior of marine mammals from tag data also continue with Colin Ware taking advantage of new low-cost tags that now include gyroscopes to provide more information about the angular velocity of the tagged animal and enabling better estimates of energy expenditure during various phases of foraging.

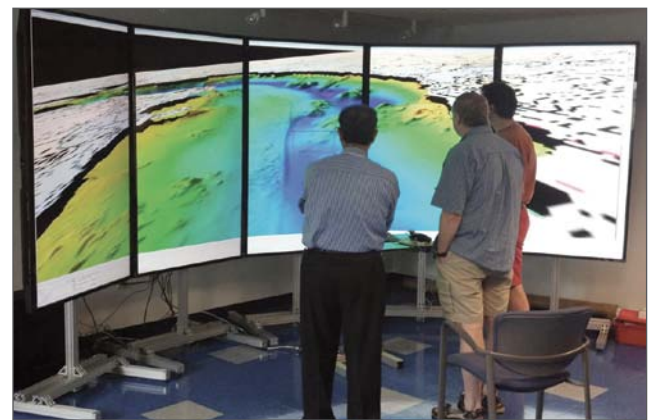

Figure ES-14. The Center's new semi-immersive display in use. Its large format allows multiple users to examine and analyze data collaboratively in the same space.

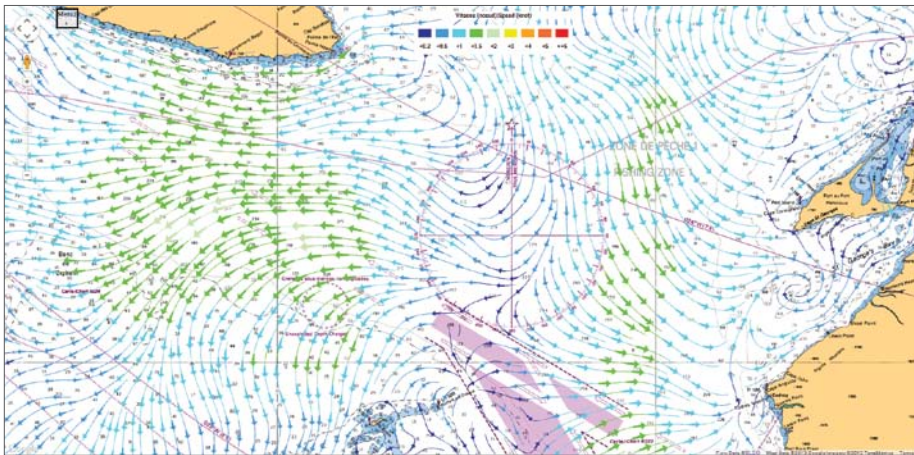

Figure ES-15. Proposed flow-pattern scheme for the Gulf of St. Lawrence rendered over a chart background in a browser using Google Maps.

## Chart of the Future

Inherent in the Center’s data-processing philosophy is our long-held belief that the “products” of hydrographic data processing can also serve a variety of applications and constituencies well beyond hydrography. Another long-held tenet of the Center is that the standard navigation charts produced by the world’s hydrographic authorities do not do justice to the information content of high-resolution multibeam and sidescan-sonar data. We also believe that the mode of delivery of these products will inevitably be electronic—and thus the initiation of “The Chart of the Future” project. This effort draws upon our visualization team, our signal and image processors, our hydrographers, and our mariners. In doing so, it epitomizes the strength of our Center—the ability to bring together talented people with a range of skills to focus on problems that are im-

portant to NOAA and the nation. The effort has had two paths—an “evolutionary” path that tries to work within existing electronic charting standards (which are very restrictive), and a “revolutionary” path that lifts the constraint of current standards and explores new approaches that may lead to the establishment of new standards. Within the evolutionary track, we have worked with electronic-chart manufacturers on approaches for including high-density hydrographic survey data and, in particular, the concept of the “tide-aware” ENC that can vary the display

with the state of the tide. The evolutionary track also includes our work to take advantage of the Automatic Identification System (AIS) carried by many vessels to transmit and receive data from the vessels. Our AIS efforts have led to the visualization of the behavior of the *Cosco Busan* after the San Francisco Bay spill incident, evidence for a fishing trawler violating Canadian fishing regulations and damaging Canada’s Ocean Observatory (Neptune) equipment, and the creation of the vessel traffic layer in ERMA, the response application used by Unified Command during the Deepwater Horizon Spill. This application was a finalist for the Homeland Security Medal.

A very successful application of our AIS work has been its use in monitoring right whales in an LNG shipping route approaching Boston Harbor. Kurt Schwehr, in collaboration with EarthNC, developed an iOS application

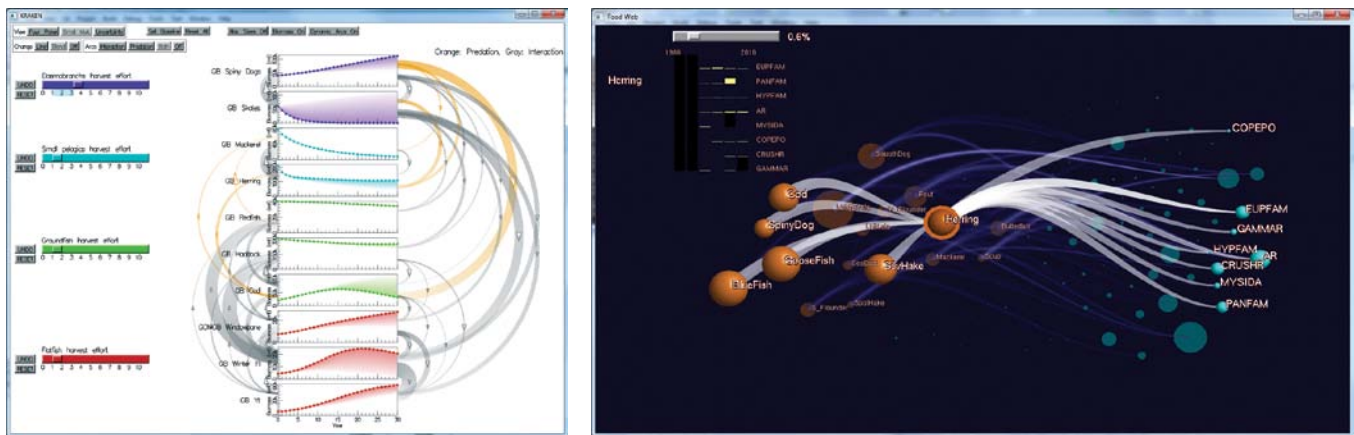

Figure ES-16. *Left*: Interactive visualization of the forecast for ten Gulf of Maine species based on the NOAA KRAKEN model. The effects of increasing the catch of Elasmobranchs is visualized. The arcs show causal links in the model, with predation in yellow and species competition in grey. *Right*: Food web visualization based on NE Fisheries data. Herring has been selected; herring predator species are shown to the left, herring prey species are shown to the right. Other species can be interactively selected to reveal their major predators and prey species. The layout adjusts automatically.



that allows display on an iPad, iPhone, and other hand-held devices. This year, Roland Arsenault extended the capability to a web-based application that serves as a cross-platform alternative to the iPad WhaleALERT app and has the ability to generate KML files so that WhaleALERT data can be viewed dynamically in Google Earth (Figure ES-17).

The revolutionary track for the Chart of the Future involves 3D displays and much more interactivity. In the last few years, the focus of this effort has been the development of GeoCoastPilot, a research software application built to explore techniques for simplifying access to the navigation information a mariner needs prior to entering or leaving a port. GeoCoastPilot is not intended to be used directly for navigation purposes, but instead is intended to demonstrate what is possible with current technology and to facilitate technology transfer. With such a digital product, the mariner, in real-time, on the vessel or before entering a harbor, could explore, through the click of a mouse, any object identified in the text and see a pictorial representation (in 2D or 3D) of the object in a geospatial context. Conversely, a click on a picture of an object will directly link to the full description of the object as well as other relevant information. GeoCoastPilot turns the NOAA Coast Pilot manual into an interactive document linked to a 3D map environment that provides linkages between the written text, 2D and 3D views, web content and other primary sources such as charts, maps, and related federal regulations. This visualization

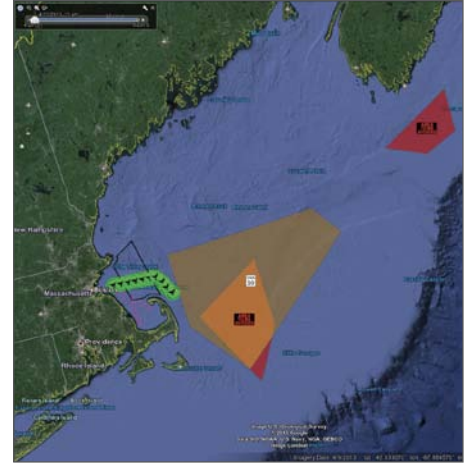

Figure ES-17. *Left:* WhaleALERT iPad app. Credit: NOAA. *Right:* Web-based WhaleALERT data as a dynamically updating KML layer in Google Earth.

technique helps the mariner become familiar with the relative location of critical navigation-related features within a port before ever going there. This year's efforts were focused on further developing automated techniques for incorporating Local Notice to Mariners into the digital products and perhaps the GeoCoastPilot (Figure ES-18). The project called Chart Update Mashup (CHuM) led by Briana Sullivan, involves the development of a small, specialized mashup application designed to work with Google Maps. CHuM displays the chart catalog and nautical charts in a geo-referenced environment, along with the critical corrections to the chart and the Coast Pilot with geo-referenced links (Figure ES-18). An outgrowth of this effort is the initiation of a project with the U.S. Navy to expand the capabilities of CHuM and explore ways to serve current, tide, and meteorological data in support of the submarine fleet.

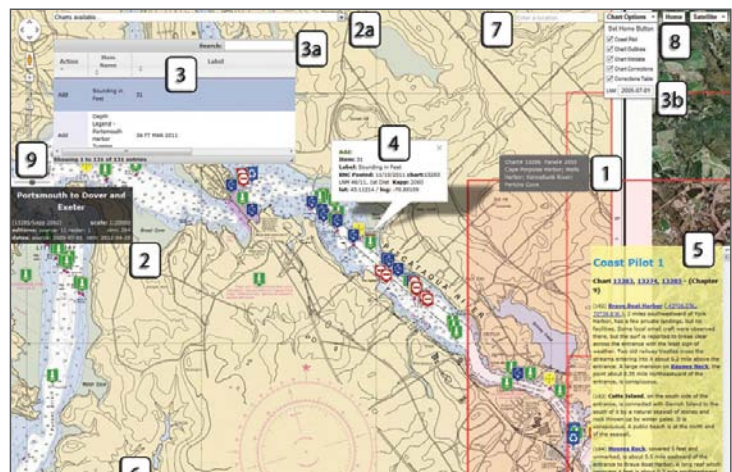
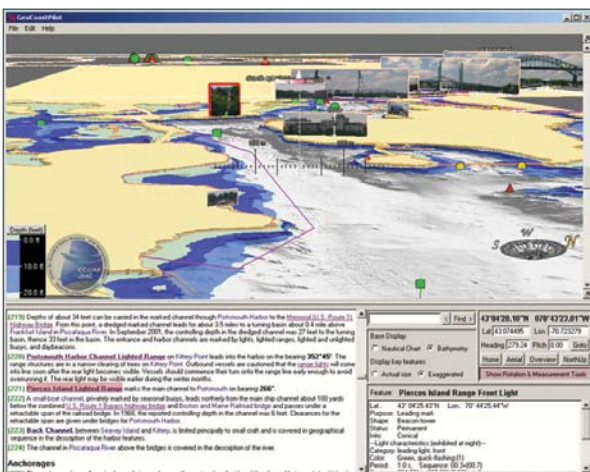

Figure ES-18. GeoCoastPilot (*left*) and ChuM prototype (*right*).



## Law of the Sea

Recognizing that implementing the United Nations Convention on the Law of the Sea (UNCLOS) could confer sovereign rights and management authority over large (and potentially resource-rich) areas of the seabed beyond our current 200 nautical mile limit, Congress (through NOAA) funded the Center to evaluate the content and completeness of the nation’s bathymetric and geophysical data holdings in areas surrounding our Exclusive Economic Zone, or EEZ ([www.com.unh.edu/unclos](http://www.com.unh.edu/unclos)). Following up on the recommendations made in the UNH study, the Center has been funded, through NOAA, to collect new multibeam sonar data in support of a potential submission for an Extended Continental Shelf (ECS) under UNCLOS Article 76.

Since 2003, Center staff have lead surveys in the Bering Sea, the Gulf of Alaska, the Atlantic margin, the ice-covered Arctic, the Gulf of Mexico, and the eastern, central and western Pacific Ocean, collecting 2,070,000 km<sup>2</sup> of multibeam bathymetry and backscatter data that have provided an unprecedented high-resolution view of the seafloor. These data are revolutionizing our understanding of many geological processes on the margins and will result in significant additions to a potential U.S. ECS under UNCLOS, particularly in the Arctic.

Budget reductions resulted in no U.S. Law of the Sea cruises in 2013, but Center staff have continued to play an active and important role in managing and archiving the Law of the Sea data as well participating in a range of Law of the Sea Task Force activities. Jim Gardner, Larry Mayer and Andy Armstrong are heavily involved in analyzing ECS data and participating in ECS Task Force, Working Group, Integrated Regional Team and other Law of the Sea-related meetings including a three-day U.S. State Department-led workshop held in Washington, DC to critique a pilot submission for the U.S. Western Gulf of Mexico.

Demonstrating the value of the ECS multibeam sonar data beyond the establishment of an extended continental shelf, Jim Gardner spent much of 2013 involved in writing peer-reviewed journal articles and a USGS Open-File Report all using ECS data. Additionally, graduate student Derek Sowers, under the supervision of Larry Mayer, has been investigating the potential of using the data collected in support of ECS studies for broad-scale habitat mapping. This effort will attempt to use the multibeam bathymetry and backscatter data collected on ECS (and other cruises) along with the ancillary data sets to see if the Atlantic Margin can be characterized using NOAA’s Coastal and Marine Ecological Classification Standard (CMECS) (Figures ES-19a and ES-19b).

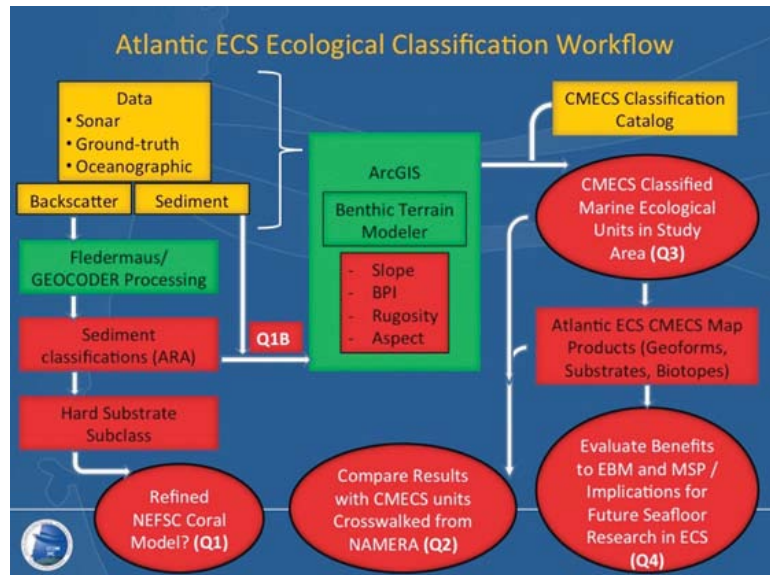

Figure ES-19a. Approach to using ECS multibeam sonar data (and ancillary data sets) to generate habitat relevant maps of the Atlantic Margin.

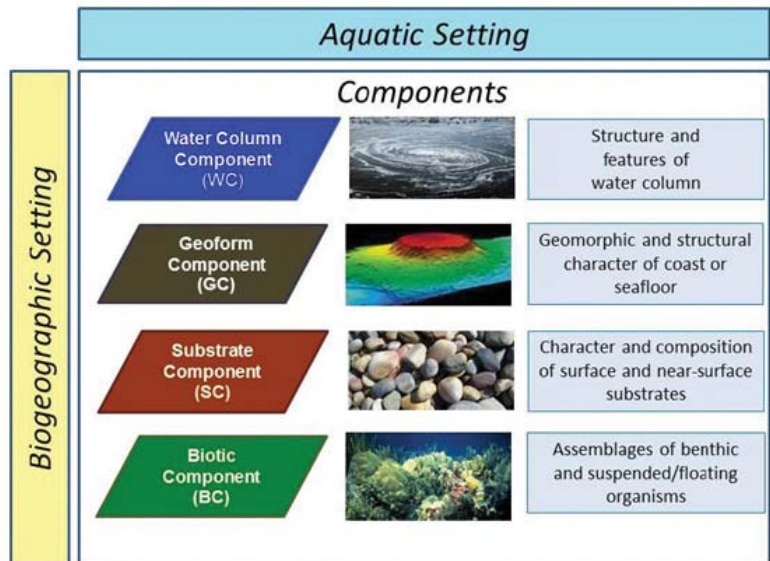

Figure ES-19b. Components of the CMECS Classification Standard—from NOAA.

## Outreach

In addition to our research efforts, we recognize the interest that the public takes in the work we do and our responsibility to explain the importance of what we do to those who ultimately bear the cost of our work. One of the primary methods of this communication is our website ([www.ccom.unh.edu](http://www.ccom.unh.edu)) that underwent a substantial redesign and upgrade in 2011. Visits to the site in 2013 (41,329) represent a nearly 50% increase over last year with the visit duration also increasing substantially.

We also recognize the importance of engaging young people in our activities so as to ensure that we will have a steady stream of highly skilled workers in the field. To this end, we have upgraded other aspects of our web presence including a Flickr stream, Vimeo site, and a Facebook page. Our Flickr stream currently has 1,735 photos with over 91,452 views since 2009, and our videos were viewed 2391 times in 2013. Our seminar series is widely advertised and webcast, allowing NOAA employees and our Industrial Partners around the world to listen and participate in the seminars. Our seminars are recorded and uploaded to Vimeo. We have actively expanded our outreach activities and now have a dedicated outreach staffer, Tara Hicks Johnson. This past year, Tara hosted tours of the Center for thousands of school children and many community groups.

Several large and specialized events were organized by the Center outreach team, including numerous SeaPerch ROV events and the annual UNH Ocean Discovery Days. The SeaPerch ROV events are coordinated with the Portsmouth Naval Shipyard (PNS). Students build ROVs and bring them to the Center to test them in our deep tank (and also tour the Center and the Engineering facilities on campus). In this year's annual SeaPerch Competition, 17 teams from Maine and New Hamp-

shire schools competed in several events. In a timed obstacle course, the teams had to maneuver their ROV through a series of underwater hoops, and then trace their steps back. A salvage operation challenged the students to remove weighted buckets from the bottom of the pool using their ROVs. In the afternoon challenge event, the students had to modify their ROVs using materials found around the lab in order to scoop up ping pong balls representing an oil spill from an exploded rig (Figure ES-20).

Ocean Discovery Days brought more than 1,000 students from school groups and home school associations from all over New Hampshire to visit our facilities and learn about the research happening at the Center. Activities and demonstrations for all ages highlighted research on acoustics, ocean mapping, ROVs, lidar, and data visualization.

Further outreach is coordinated through the use of the Telepresence Console to communicate with Bob Ballard's E/V *Nautilus* and its "Educators at Sea" program, and the researchers and technicians aboard the NOAA Ship *Okeanos Explorer*. Students visiting the Center have been able to chat live with ROV pilots, technicians, researchers and graduate students while they participate in research cruises.

Center activities have been featured in many international, national, and local media outlets including, this year, *The Los Angeles Times*, *The Wall Street Journal*, *National Geographic*, *The Washington Post*, and *The Boston Globe*.

The highlights presented here represent only a fraction of the activities of the Joint Hydrographic Center. More detailed discussions of these and other activities of the Center can found in the full progress report.



Figure ES-20. Teams prepare for the collapse of an "oil rig" and subsequent spill that they will be charged to clean up with the ROVs they have built.

 On 4 June 1999, the Administrator of NOAA and the President of the University of New Hampshire signed a memorandum of understanding establishing a Joint Hydrographic Center (JHC) at the University of New Hampshire. On 1 July 1999, a cooperative agreement was awarded to the University of New Hampshire that provided the initial funding for the establishment of the Joint Hydrographic Center. This Center, the first of its kind to be established in the United States, was formed as a national resource for the advancement of research and education in the hydrographic and ocean-mapping sciences. In the broadest sense, the activities of the Center are focused on two major themes: a research theme aimed at developing and evaluating a wide range of state-of-the-art hydrographic and ocean-mapping technologies and applications, and an educational theme aimed at establishing a learning center that will promote and foster the education of a new generation of hydrographers and ocean-mapping scientists to meet the growing needs of both government agencies and the private sector. In concert with the Joint Hydrographic Center, the Center for Coastal and Ocean Mapping was also formed in order to provide a mechanism whereby a broader base of support (from the private sector and other government agencies) could be established for ocean-mapping activities.

The Joint Hydrographic Center was funded by annual cooperative agreements from July 1999 until 31 December 2005. In 2005, a five-year cooperative agreement was awarded with an ending date of 31 December 2010. In January 2010, a Federal Funding Opportunity was announced for the continuation of a Joint Hydrographic Center beyond 2010. After a national competition, the University of New Hampshire was selected as the recipient of a five-year award, funding the Center for the period of 1 July 2010 until December 2015.

This report is the eighteenth in a series of what were, until December 2002, semi-annual progress reports. Since December 2002, the written reports have been produced annually. This report provides an overview of the activities of the Joint Hydrographic Center, highlighting the period between 1 January and 31 December 2013. As such, it represents the fourth written progress report for the current grant (NA10NOS4000073). Previous reports and more detailed information about the Center can be found on the Center's website, [www.ccom.unh.edu](http://www.ccom.unh.edu). More detailed descriptions of many of the research efforts described herein can be found in the individual progress reports of Center researchers that are available on request.

## Infrastructure

### Personnel

The Center has grown over the past 14 years from an original complement of 18 people to more than 80 faculty, staff, and students although, in 2013, budget constraints prevented us from replacing or filling several positions. Our faculty and staff have been remarkably stable but as with any large organization, inevitably, there are changes. In 2013, **Jodi Pirtle** finished her post-doc with the Center and moved back to her native Alaska to take up a position with the NOAA Alaska Fisheries Science Center in Juneau. **Jim Gardner** has begun to take seriously his "second retirement" and has reduced his efforts to half-time while **Adam Skarke**, a NOAA OER employee assigned to the IOCM center at UNH, accepted a faculty position at the Mississippi State University, and computer specialist **Les Peabody** moved to the private sector, taking a position as a web engineer with Genuine Interactive in Boston, MA.

We have also had some additions and change in status for our personnel. Two of our master's degree students who graduated in 2013, **Lindsay McKenna** and **Christy Fandel**, were hired by NOAA but continue to work at the Center on data analyses associated with Hurricane Sandy Supplemental funds. **Tom Lippmann's** position was changed from Associate Research Professor to Associate Professor with a new tenure-track appointment split between the Earth Science Dept. and the Center, and **Carlo Lanzoni** was promoted to a Project Research Specialist II. **Giuseppe Masetti**, who received a Master of Science degree from the Center in 2012, has returned as a Tyco Post-Doctoral Fellow after completing a Ph.D. in Italy. Finally, **Megan Greenaway**, a NOAA physical scientist, has started at the Center working with the IOCM group.



## Faculty

**Lee Alexander** is a Research Associate Professor at the Center for Coastal and Ocean Mapping and Joint Hydrographic Center at the University of New Hampshire, and an Adjunct Professor at both the University of New Brunswick and Memorial University of Newfoundland, Canada. Previously a Research Scientist with the U.S. Coast Guard, he was also a Visiting Scientist with the Canadian Hydrographic Service. His area of expertise is applied Research, Development, Test and Evaluation (RDT&E) on e-Navigation related technologies, international standards development, and the use of electronic charts for safety-of-navigation and marine environmental protection. He serves on several international committees and working groups dealing with electronic charting and e-Navigation, including the International Hydrographic Organization, International Maritime Organization, and the International Association of Lighthouse Authorities. Dr. Alexander has published over 150 papers and reports on electronic chart-related technologies, and is the co-author of a textbook on Electronic Charting, now in Third Edition. Dr. Alexander received his M.S. from the University of New Hampshire, and Ph.D. from Yale University in Natural Resource Management. He is also a Captain (now retired) in the U.S. Navy Reserve.

**Jonathan Beaudoin** has a Ph.D. (2010) in Geodesy and Geomatics Engineering from the University of New Brunswick and bachelor's degrees in Geodesy and Geomatics Engineering (2002) and Computer Science (2002), also from UNB. Having arrived at JHC/CCOM in the spring of 2010, he has carried on in the field of his Ph.D. research estimating sounding uncertainty from measurements of water mass variability. His research includes an examination of oceanographic resources such as the World Ocean Atlas, the World Ocean Database and real-time oceanographic predictive models to see how the data contained in these comprehensive collections can be turned into information that is meaningful to a hydrographic surveyor. Other research involves assessing how to best acquire, visualize, process, and analyze data from high-resolution underway sound speed sampling systems, again, in terms that are meaningful to a hydrographic surveyor. Jonathan has also become involved with the seafloor characterization projects, adding his experience in processing and normalization of backscatter measurements from a variety of multibeam echosounder systems to the team skill set.

**Thomas Butkiewicz** received a Bachelor of Science degree in Computer Science from Ithaca College in 2005, where he focused on computer graphics and virtual reality research. During his graduate studies at The University of North Carolina at Charlotte, he designed and developed new interactive geospatial visualization techniques, receiving a Master's in Computer Science in 2007 and a Ph.D. in Computer Science in 2010. After a year as a research scientist at The Charlotte Visualization Center, he joined JHC/CCOM as a post-doctoral research fellow in 2011. In 2012 he joined the faculty as a research assistant professor.

Dr. Butkiewicz specializes in creating highly interactive visualizations that allow users to perform complex visual analysis on geospatial datasets through unique, intuitive exploratory techniques. His research interests also include multi-touch and natural interfaces, virtual reality, stereoscopic displays, and image processing/computer vision. His current research projects include visual analysis of 4D dynamic ocean simulations, using Microsoft's Kinect device to enhance multi-touch screens and provide new interaction methods, multi-touch gesture research, and developing new interface approaches for sonar data cleaning.

**Brian Calder** graduated with an M.Eng (Merit) and Ph.D in Electrical and Electronic Engineering in 1994 and 1997 respectively, from Heriot-Watt University, Scotland. His doctoral research was in Bayesian statistical methods applied to processing of sidescan sonar and other data sources, and his post-doctoral research included investigation of high-resolution seismic reconstruction, infrared data simulation, high-resolution acoustic propagation modeling and real-time assessment of pebble size distributions for mining potential assessment. Brian joined JHC/CCOM as a founding member in 2000, where his research has focused mainly on understanding, utilizing and portraying the uncertainty inherent in bathymetric data, and in efficient semi-automatic processing of high-density multibeam echosounder data. He is a Research Associate Professor, and Associate Director of CCOM, the Chair of the Open Navigation Surface Working Group, and a past Associate Editor of IEEE Journal of Oceanic Engineering.

**Jenn Dijkstra** received a Ph.D. in Zoology in 2007 at the University of New Hampshire. She has a B.A. from the University of New Brunswick (Canada), and a M.S. in Marine Biology from the University of Bremen (Germany). She has conducted research in a variety of geographical areas and habitats, from polar to tropical and from intertidal to deep-water. Her research incorporates observation and experimental approaches to address questions centered around the ecological causes and consequences of human-mediated effects on benthic and coastal communities. Her research at the Center focuses on the use of remote sensing (video and multibeam) to detect and characterize benthic communities.

**Semme Dijkstra** is a hydrographer from the Netherlands who has several years of hydrographic experience with both the Dutch Navy and industry. Dr. Dijkstra earned his Ph.D. in Geodesy and Geodetic Engineering from the University of New Brunswick in Canada. His thesis work involved artifact removal from multibeam-sonar data and development of an echosounder processing and sediment classification system. From 1996 to 1999, Dr. Dijkstra worked at the Alfred Wegner Institute in Germany where he was in charge of their multibeam-sonar data acquisition and processing. Dr. Dijkstra's current research focuses on applications of single-beam sonars for seafloor characterization, small object detection and fisheries habitat mapping. In 2008, Dr. Dijkstra was appointed a full-time instructor and he has taken a much larger role in evaluating the Center's overall curriculum, the development of courses and teaching..

**Jim Gardner** is a marine geologist focused on seafloor mapping, marine sedimentology, and paleoceanography. He received his Ph.D. in Marine Geology from the Lamont Doherty Earth Observatory of Columbia University in 1973. He worked for 30 years with the Branch of Pacific Marine Geology at the U.S. Geological Survey in Menlo Park, CA where he studied a wide variety of marine sedimentological and paleoceanographic problems in the Bering Sea, North and South Pacific Ocean, northeast Atlantic Ocean, Gulf of Mexico, Caribbean and Mediterranean Seas, and the Coral Sea. He conceived, organized, and directed the eight-year EEZ-SCAN mapping of the U.S. Exclusive Economic Zone using GLORIA long-range sidescan sonar in the 1980s; participated in four Deep Sea Drilling Project cruises, one as co-chief scientist; participated in more than 50 research cruises, and was Chief of Pacific Seafloor Mapping from 1995 to 2003, a project that used high-resolution multibeam echosounders to map portions of the U.S. continental shelves and margins. He also mapped Lake Tahoe in California and Crater Lake in Oregon. Jim was the first USGS Mendenhall Lecturer, received the Department of Interior Meritorious Service Award and received two USGS Shoemaker Awards. He has published more than 200 scientific papers and given an untold number of talks and presentations all over the world. Jim retired from the U.S. Geological Survey in 2003 to join JHC/CCOM.

Jim was an Adjunct Professor at the Center from its inception until he moved to UNH in 2003 when he became a Research Professor affiliated with the Earth Science Department. At JHC/CCOM, Jim is in charge of all non-Arctic U.S. Law of the Sea bathymetry mapping cruises as well as involved in research methods to extract meaningful geological information from multibeam acoustic backscatter through ground truth and advanced image analysis methods. Jim was awarded the 2012 Francis P. Shepard Medal for Sustained Excellence in Marine Geology by the SEPM Society of Sedimentary Geology. Jim has taught Geological Oceanography, ESCI 759/859, and the Geological Oceanography module of Fundamentals of Ocean Mapping, ESCI 874/OE 874.01. In 2013, Jim reduced his effort to half-time.

**Jim Irish** received his Ph.D. from Scripps Institution of Oceanography in 1971 and worked many years at the Woods Hole Oceanographic Institution where he is still an Oceanographer Emeritus. He is currently a Research Professor of Ocean Engineering at UNH and has also joined the Center team. Jim's research focuses on: ocean instruments, their calibration, response and the methodology of their use; buoys, moorings and modeling of moored observing systems; physical oceanography of the coastal ocean, including waves, tides, currents and water-mass property observations and analysis; and acoustic instrumentation for bottom sediment and bedload transport, for remote observations of sediment and for fish surveys.

**Tom Lippmann** is an Associate Professor with affiliation in the Department of Earth Sciences, Marine Program, and Ocean Engineering Graduate Program, and is currently the Director of the Oceanography Graduate Program. He received a B.A. in Mathematics and Biology from Linfield College (1985), and an M.S. (1989) and Ph.D. (1992) in

Oceanography at Oregon State University. His dissertation research conducted within the Geological Oceanography Department was on shallow water physical oceanography and large-scale coastal behavior. He went on to do a Post Doc at the Naval Postgraduate School (1992–1995) in Physical Oceanography. He worked as a Research Oceanographer at Scripps Institution of Oceanography (1995–2003) in the Center for Coastal Studies. He was then a Research Scientist at Ohio State University (1999–2008) jointly in the Byrd Polar Research Center and the Department of Civil and Environmental Engineering and Geodetic Science. Dr. Lippmann’s research is focused on shallow water oceanography, hydrography, and bathymetric evolution in coastal waters spanning inner continental shelf, surf zone, and inlet environments. Research questions are collaboratively addressed with a combination of experimental, theoretical, and numerical approaches. He has participated in 20 nearshore field experiments and spent over two years in the field.

**Larry Mayer** is the founding Director of the Center for Coastal and Ocean Mapping and Co-Director of the Joint Hydrographic Center. Larry’s faculty position is split between the Ocean Engineering and Earth Science Departments. His Ph.D. is from the Scripps Institution of Oceanography (1979) and he has a background in marine geology and geophysics with an emphasis on seafloor mapping, innovative use of visualization techniques, and the remote identification of seafloor properties from acoustic data. Before coming to New Hampshire, he was the NSERC Chair of Ocean Mapping at the University of New Brunswick where he led a team that developed a worldwide reputation for innovative approaches to ocean mapping problems.

**Dave Monahan** is the Program Director for the Nippon Foundation’s General Bathymetric Chart of the Oceans (GEBCO) training program in oceanic bathymetry. Prior to joining the Center, he served 33 years in the Canadian Hydrographic Service, working his way up from Research Scientist to Director. During that time, he established the bathymetric mapping program and mapped most Canadian waters, built the Fifth Edition of GEBCO, led the development of lidar, developed and led the CHS Electronic Chart production program, and was Canadian representative on a number of international committees and boards. He is the past chair of GEBCO and still remains very active in the organization.

**Shachak Pe’eri** received his Ph.D. degree in Geophysics from the Tel Aviv University, Israel. In 2005, he started his post-doctoral work at the Center with a Tyco post-doctoral fellowship award. He is currently working as a research assistant professor at JHC/CCOM. His research interests are in optical remote sensing in the littoral zone with a focus on experimental and theoretical studies of lidar remote sensing (airborne lidar bathymetry, topographic lidar, and terrestrial laser scanning), hyperspectral remote sensing, and sensor fusion. Shachak Pe’eri is a member of the (American Geophysical Union) AGU and the Ocean Engineering (OE) and Geoscience and Remote Sensing (GRS) societies of IEEE and of The Hydrographic Society of America (THSOA).

**Yuri Rzhanov**, a research professor, has a Ph.D. in Physics and Mathematics from the Russian Academy of Sciences. He completed his thesis on nonlinear phenomena in solid state semiconductors in 1983. Since joining the Center in 2000, he has worked on a number of signal processing problems, including construction of large-scale mosaics from underwater imagery, automatic segmentation of acoustic backscatter mosaics, and accurate measurements of underwater objects from stereo imagery.

His research interests include development of algorithms and their implementation in software for 3D reconstruction of underwater scenes, and automatic detection and abundance estimation of various marine species from imagery acquired from ROVs, AUVs, and aerial platforms.

**Larry Ward** has an M.S. (1974) and a Ph.D. (1978) from the University of South Carolina in Geology. He has over 30 years’ experience conducting research in shallow water marine systems. Primary interests include estuarine, coastal, and inner shelf morphology and sedimentology. His most recent research focuses on seafloor characterization and the sedimentology, stratigraphy and Holocene evolution of nearshore marine systems. Present teaching includes a course in Nearshore Processes and a Geological Oceanography module.



**Colin Ware** is a leading scientific authority on the creative invention, and the scientifically sound, correct use of visual expressions for information visualization. Ware's research is focused on applying an understanding of human perception to interaction and information display. He is author of *Visual Thinking for Design* (2008) which discusses the science of visualization and has published more than 120 research articles on this subject. His other book, *Information Visualization: Perception for Design* (2004) has become the standard reference in the field. He also designs, builds and experiments with visualization applications.

One of his main current interests is interpreting the space-time trajectories of tagged foraging humpback whales and to support this he has developed TrackPlot an interactive 3D software tool for interpreting both acoustic and kinematic data from tagged marine mammals. TrackPlot, shows interactive 3D tracks of whales with whale behavioral properties visually encoded on the tracks. This has resulted in a number of scientific discoveries, including a new classification of bubble-net feeding by humpbacks. Fledermaus, a visualization package initially developed by him and his students is now the leading 3D visualization package used in ocean mapping applications. GeoZui4D is an experimental package developed by his team in an initiative to explore techniques for interacting with time-varying geospatial data. It is the basis for the Center's Chart of the Future project and work on real-time visualization of undersea sonar data. In recent work with BBN he invented a patented technique for using motion cues in the exploration of large social networks. He has worked on the problem of visualizing uncertainty for sonar target detection.

He is Professor of Computer Science and Director of the Data Visualization Research Lab at the Center for Coastal and Ocean Mapping, University of New Hampshire. He has advanced degrees in both computer science (M.Math, University of Waterloo) and psychology (Ph.D., University of Toronto).

**Thomas Weber** received his Ph.D. in Acoustics at The Pennsylvania State University in 2006 and has a B.S. (1997) and an M.S. (2000) degrees in Ocean Engineering from the University of Rhode Island. He joined the Center in 2006 and the Mechanical Engineering Department, as an assistant professor, in 2012. Dr. Weber conducts research in the field of underwater acoustics and acoustical oceanography. His specific areas of interest include acoustic propagation and scattering in fluids containing gas bubbles, the application of acoustic technologies to fisheries science, high-frequency acoustic characterization of the seafloor, and sonar engineering.

## Research Scientists and Staff

**Roland Arsenault** received his bachelor's degree in Computer Science and worked as a research assistant with the Human Computer Interaction Lab at the Department of Computer Science, University of New Brunswick. As a member of the Data Visualization Research Lab, he combines his expertise with interactive 3D graphics and his experience working with various mapping related technologies to help provide a unique perspective on some of the challenges undertaken at the Center.

**Jordan Chadwick** is the Systems Manager at JHC/CCOM. As the Systems Manager, Jordan is responsible for the day-to-day operation of the information systems and network as well as the planning and implementation of new systems and services. Jordan has a B.A. in History from the University of New Hampshire. He previously worked as a Student Engineer at UNH's InterOperability Lab and, most recently, as a Network Administrator in the credit card industry.

**Christy Fandel** is a research scientist for the Center where she is examining post Hurricane Sandy acoustic data. She received her Master of Science in Earth Sciences - Ocean Mapping from the University of New Hampshire in 2013. Her research focused on the maintenance mechanisms and flow circulation patterns within pockmarks in Belfast Bay, Maine. During her graduate career, Christy participated in multiple oceanographic research cruises in the Arctic aboard the USCGC *Healy* and off the coast of Charleston, SC aboard the NOAA Ship *Ronald H. Brown*. Christy graduated from the College of Charleston in 2010 with a B.S. in Geology and Environmental Geosciences.

**Will Fessenden** is a Systems Administrator for JHC/CCOM, and workstation, server, and backup support to the Center since 2005. Will has a B.A. in Political Science from the University of New Hampshire, and has over 15 years of experience in information technology.

**Tara Hicks Johnson** has a B.S. in Geophysics from the University of Western Ontario, and an M.S. from the University of Hawaii at Manoa in Geology and Geophysics, where she studied meteorites. In June of 2011, Tara moved to New Hampshire from Honolulu, Hawaii, where she was the Outreach Specialist for the School of Ocean and Earth Science and Technology at the University of Hawaii at Manoa. While there, she organized educational and community events for the school, including the biennial Open House event, and ran the Hawaii Ocean Sciences Bowl—the Aloha Bowl. She also handled media relations for the School, and coordinated television production projects. Tara also worked with the Bishop Museum in Honolulu developing science exhibits and at the Canadian Broadcasting Corporation in Toronto where she was born and raised.

**Tianhang Hou** was a Research Associate with the University of New Brunswick Ocean Mapping for six years before coming to UNH. He has significant experience with the UNB/OMG multibeam processing tools and has taken part in several offshore surveys. In addition to his work as a research scientist Mr. Hou has also begun a Ph.D in which he is looking at the application of wavelets for artifact removal and seafloor classification in multibeam sonar records. He is currently working with Tom Weber and Jonathan Beaudoin developing plug-in software modules for seafloor characterization and mid-water data processing.

**Jon Hunt** is a UNH alumnus who studied economics and oceanography while a student at the university. Jon is now a Research Technician at the Center. Working under the supervision of Tom Lippmann, Jon has built a survey vessel which is capable of undertaking both multibeam sonar surveys and measurements of currents. Jon is a certified research scuba diver and has been a part of many field work projects for the Center.

**Paul Johnson** has an M.S. in Geology and Geophysics from the University of Hawaii at Manoa where he studied the tectonics and kinematics of the fastest spreading section of the East Pacific Rise. Since finishing his masters, he has spent time in the remote sensing industry processing, managing, and visualizing hyperspectral data associated with coral reefs, forestry, and research applications. More recently, he was the interim director of the Hawaii Mapping Research Group at the University of Hawaii where he specialized in the acquisition, processing, and visualization of data from both multibeam mapping systems and towed near bottom mapping systems. Paul started at the Center in June of 2011 as the data manager. When not working on data related issues for the Joint Hydrographic Center, he is aiding in the support of multibeam acquisition for the US academic fleet through the National Science Foundation's Multibeam Advisory Committee.

**Carlo Lanzoni** received a master's degree in Ocean Engineering from the University of New Hampshire. His master's research was the design of a methodology for field calibration of multibeam echosounders using a split-beam sonar system and a standard target. He also has an M.S. and a B.S. in Electrical Engineering from the University of New Hampshire. Carlo has worked with different calibration methodologies applied to different sonar systems. He is responsible for the operation, maintenance, and development of test equipment used in acoustic calibrations of echosounders at the acoustic tank of Chase Ocean Engineering Lab. His research focuses on the field calibration methodology for multibeam echosounders.

**Lindsay McKenna** is Project Director for a Hurricane Sandy research project, developing methods to efficiently process and map lidar point cloud data to support habitat mapping and shoreline retreat in post-disaster situations. Lindsay initially joined the JHC/CCOM community in 2010 as a master's student. Before graduate school, Lindsay was employed as a geologist at Malcolm Pirnie, Inc. in New Jersey, where she worked on a variety of water resource projects. Lindsay earned her Sc.B. in Geological Sciences from Brown University in 2007, and her M.S. in Earth Science - Ocean Mapping from the University of New Hampshire in 2013.

**Andy McLeod** received his B.S. in Ocean Studies from Maine Maritime Academy in 1998. His duties at the Center include managing projects from conception, pre-production through to completion, providing technical support to the Center and wider regional projects, managing project budgets and keeping costs down, overseeing the maintenance and operations of projects after initiation, responsibility for the completion of all documentation, producing test plans and reports, prepare contract documentation for procurement services and materials, carrying out effective client liaison for all projects undertaken, as well as liaising with manufacturers, development interests and customers on a regular basis to ensure the successful design and manufacture of products to agreed budgets and time frames.

**Colleen Mitchell** earned a B.A. in English from Nyack College in Nyack, NY and a Master's in Education from the State University of New York at Plattsburgh. She began working for the Environmental Research Group at UNH in 1999. In July 2009, Colleen joined JHC/CCOM as the Center's graphic designer. She is responsible for the graphic identity of the Center and, in this capacity, creates ways to visually communicate the Center's message in print and electronic media.

**Abby Pagan-Allis** is the administrative manager at JHC/CCOM. She has worked at the Center since 2002 and oversees the day-to-day operations at the Center, as well as supervises the administrative staff. She earned her B.S. in Management and Leadership from Granite State College. In 2006, she completed the Managing at UNH program, and in 2009, she received her Human Resources Management certificate at the University of New Hampshire.

**Matt Plumlee** became a Research Scientist with the Center after completing his Ph.D. at UNH under Dr. Colin Ware. Matt is continuing his work on data visualization and human-computer interaction on a part-time basis. He is focusing his efforts on the Chart of the Future project and in particular the Digital Coast Pilot.

**Val Schmidt** received his bachelor's degree in Physics from the University of the South in Sewanee, TN in 1994. During his junior undergraduate year, he joined the Navy and served as an officer in the submarine fleet aboard the USS *Hawkbill* from 1994 to 1999. In 1998 and 1999, the USS *Hawkbill* participated in two National Science Foundation sponsored "SCICEX" missions to conduct seafloor mapping from the submarine under the Arctic ice sheet. Val served as Sonar and Science Liaison Officer during these missions. Val left the Navy in 1999 and worked for Qwest Communications as a telecommunications and Voice over IP engineer from 2000 to 2002. Val began work in 2002 as a research engineer for the Lamont Doherty Earth Observatory of Columbia University where he provided science engineering support both on campus and to several research vessels in the U.S. academic research fleet. Val acted as a technical lead aboard the US Coast Guard Icebreaker *Healy* for several summer cruises in this role. Val completed his master's degree in Ocean Engineering in 2008 from the Center for Coastal and Ocean Mapping at the University of New Hampshire. His thesis involved development of an underwater acoustic positioning system for whales that had been tagged with an acoustic recording sensor package. Val continues to work as an engineer with the Center for Coastal and Ocean Mapping. His research focuses on seafloor and water column mapping from autonomous underwater vehicles, sensor development, and sonar signal processing and calibration.

**Ben Smith** is the Captain of the JHC/CCOM research vessel *Coastal Surveyor*, and a research technician specializing in programming languages and UNIX-like operating systems and services. He has years of both programming and marine experience. He designed, built, and captained his own 45-foot blue water steel ketch, *SN Mother of Perl*. He has been master of *Coastal Surveyor* for over ten years. He holds a USCG 100 ton near coastal license with endorsements for sail and rescue towing.

**Briana Sullivan** received a B.S. in Computer Science at UMASS, Lowell and an M.S. in Computer Science at UNH, under the supervision of Dr. Colin Ware. Her master's thesis involved linking audio and visual information in a virtual underwater kiosk display that resulted in an interactive museum exhibit at the Seacoast Science Center. Briana was hired in July 2005 as a research scientist for the Center. She works on the Chart of the Future project which involves things such as the Local Notice to Mariners, ship sensors, the Coast Pilot, other marine related topics. Her focus is on web technologies and mobile environments.

**Emily Terry** joined JHC/CCOM as Relief Captain in 2009. She focuses her efforts on operating and maintaining the Research Vessel *Cocheco*. She came to JHC/CCOM from the NOAA Ship *Fairweather* where she worked for three years as a member of the deck department, separating from the ship as a Seaman Surveyor. Prior to working for NOAA, she spent five years working aboard traditional sailing vessels. Emily holds a USCG 100 ton near coastal license.

**Rochelle Wigley** has a mixed hard rock/soft rock background with an M.S. in Igneous Geochemistry (focusing on dolerite dyke swarms) and a Ph.D. in sedimentology/sediment chemistry, where she integrated geochemistry and geochronology into marine sequence stratigraphic studies of a condensed sediment record in order to improve the understanding of continental shelf evolution along the western margin of southern Africa. Phosphorites and



glauconite have remained as a research interest where these marine authigenic minerals are increasingly the focus of offshore mineral exploration programs. She was awarded a "Graduate Certificate in Ocean Mapping" from UNH in 2008. Rochelle concentrated largely on understanding the needs and requirements of all end-users within the South African marine sectors on her return home, as she developed a plan for a national offshore mapping program from 2009 through 2012. As Project Director of the GEBCO Nippon Foundation Indian Ocean Project, she is involved in the development of an updated bathymetric grid for the Indian Ocean and management of a project working to train other Nippon Foundation GEBCO scholars. Rochelle is currently also assisting Dave Monahan with the management and administration of the GEBCO program.

In addition to the academic, research and technical staff, our administrative assistants, **Linda Prescott** and **Maureen Claussen** ensure the smooth running of the organization.

## NOAA Employees

*NOAA has demonstrated its commitment to the Center by assigning eight NOAA employees (or contractors) to the Center.*

**Capt. Andrew Armstrong**, founding co-director of the JHC, retired as an officer in the National Ocean and Atmospheric Administration Commissioned Officer Corps in 2001 and is now assigned to the Center as a civilian NOAA employee. Captain Armstrong has specialized in hydrographic surveying and served on several NOAA hydrographic ships, including the NOAA Ship *Whiting* where he was Commanding Officer and Chief Hydrographer. Before his appointment as Co-Director of the NOAA/UNH Joint Hydrographic Center, Captain Armstrong was the Chief of NOAA's Hydrographic Surveys Division, directing all of the agency's hydrographic survey activities. Captain Armstrong has a B.S. in Geology from Tulane University and a M.S. in Technical Management from the Johns Hopkins University. Capt. Armstrong is overseeing the hydrographic training program at UNH and organized our successful Cat. A certification submission to the International Hydrographic Organization in 2011.

**John G.W. Kelley** is a research meteorologist and coastal modeler with NOAA/National Ocean Service's Marine Modeling and Analysis Programs within the Coast Survey Development Lab. John has a Ph.D. in Atmospheric Sciences from Ohio State University. He is involved in the development and implementation of NOS's operational numerical ocean forecast models for estuaries, the coastal ocean and the Great Lakes. He is also PI for a NOAA web mapping portal to real-time coastal observations and forecasts. John is working with JHC/CCOM personnel on developing the capability to incorporate NOAA's real-time gridded digital atmospheric and oceanographic forecast into the next generation of NOS nautical charts.

**Jason Greenlaw** is a software developer for ERT, Inc. working as a contractor for NOAA/National Ocean Service's Coast Survey Development Laboratory in the Marine Modeling and Analysis Programs (MMAP) branch. Jason works primarily on the development of NOAA's nowCOAST project (<http://nowcoast.noaa.gov>), but also works closely with MMAP modelers to assist in the development of oceanographic forecast systems and the visualization of model output. Jason is a native of Madbury, NH and graduated in May 2006 from the University of New Hampshire with a B.S. in Computer Science.

**Carl Kammerer** is an oceanographer with the National Ocean Service's Center for Operational Oceanographic Products and Services (CO-OPS), now seconded to the Center. He is a specialist in estuarine and near-shore currents and has been project manager for current surveys throughout the United States and its territories. His present project is a two-year survey of currents in the San Francisco Bay region. Working out of the Joint Hydrographic Center, he acts as a liaison between CO-OPS and the JHC, and provides expertise and assistance in the analysis and collection of tides. He has a B.S. in Oceanography from the University of Washington and an MBA from the University of Maryland University College.

**Elizabeth “Meme” Lobecker** is a Physical Scientist for the *Okeanos Explorer* program within the NOAA Office of Ocean Exploration and Research (OER). She organizes and leads mapping exploration cruises aboard the NOAA Ship *Okeanos Explorer*. She has spent the last ten years mapping the global ocean floor for an array of purposes, ranging from shallow water hydrography for NOAA charting and habitat management purposes in U.S. waters from Alaska to the Gulf of Maine, cable and pipeline inspection and pre-lay surveys in the Eastern Atlantic Ocean, the North Sea and Mediterranean Sea, and most recently as a Physical Scientist for OER sailing on *Okeanos Explorer* as it explores U.S. and international waters around the world. So far this has included Indonesia, Guam, Hawaii, California, the Galapagos Spreading Center, the Mid-Cayman Rise, the Gulf of Mexico, and the U.S. Atlantic continental margin. Meme obtained a Master of Marine Affairs degree from the University of Rhode Island in 2008, and a Bachelor of Arts in Environmental Studies from The George Washington University in 2000. Her interests in her current position include maximizing offshore operational efficiency in order to provide the large amounts of high quality data to the public to enable further exploration, focused research, and wise management of U.S. and global ocean resources.

**Mashkoor Malik** who received his M.S. degree from the University of New Hampshire in 2005, has been hired by NOAA (through ERT) as a physical scientist assigned to the new NOAA vessel of exploration *Okeanos Explorer*. In this capacity, Mashkoor is responsible for developing the data collection, processing and handling procedures and protocols for the . While not serving on the vessel, Mashkoor works at NOAA HQ in Silver Spring. Mashkoor also continues to be a Ph.D. student at the Center, his research focusing on understanding the uncertainty associated with backscatter measurements.

**Chris Parrish** is the Lead Physical Scientist in the Remote Sensing Division of NOAA's National Geodetic Survey (NGS) and NGS' Project Manager for Integrated Ocean and Coastal Mapping (IOCM). Chris holds an appointment as Affiliate Professor of Earth Sciences and Ocean Engineering at UNH and has been based at JHC/CCOM since 2010. Chris' academic background includes a Ph.D. in Civil and Environmental Engineering with an emphasis in Geospatial Information Engineering from the University of Wisconsin, an M.S. in Civil and Coastal Engineering from the University of Florida, and a B.S. in Physics from Bates College. His primary research interests include topographic-bathymetric lidar, waveform analysis, shoreline TPU, lidar geometric and radiometric calibration, and coastal science applications. Chris is active in the American Society for Photogrammetry and Remote Sensing (ASPRS), serving as Assistant Director of the ASPRS lidar Division and Past President of ASPRS Potomac Region. He also serves as Associate Editor of the journal *Marine Geodesy*.

**Glen Rice** started with the Center as a Lieutenant (Junior Grade) in the NOAA Corps stationed with at the Joint Hydrographic Center as Team Lead of the Integrated Ocean and Coastal Mapping Center. He had previously served aboard the NOAA Hydrographic Ships *Rude* and *Fairweather* along the coasts of Virginia and Alaska after receiving a M.S. in Ocean Engineering at the University of New Hampshire. In 2013, Glen left the NOAA Corps and became a civilian contractor to NOAA. He maintains his position as Team Lead of the ICOM Center at UNH.

**Adam Skarke** is a Physical Scientist with the NOAA Office of Ocean Exploration and Research. He is responsible for coordinating expeditions and conducting seafloor mapping in support of the ocean exploration mission of the NOAA Ship *Okeanos Explorer*. Adam is a Ph.D candidate at the University of Delaware, and holds a M.S. in geology from the University of Delaware as well as a B.A. in geology from Colgate University. His graduate research was focused on acoustic seafloor sediment characterization, parameterization of bedform morphology from sonar imagery, and sediment transport processes at the estuary-shelf interface.

## Other Affiliated Faculty

**Margaret Boettcher** received a Ph.D. in Geophysics from the MIT/WHOI Joint Program in Oceanography in 2005. She joined JHC/CCOM in 2008 as a post-doctoral scholar after completing a Mendenhall Postdoctoral Fellowship at the U.S. Geological Survey. Although she will continue to collaborate with scientists at JHC/CCOM indefinitely, Margaret also is, since 2009, a member of the faculty in the Earth Science Department at UNH. Margaret's research focuses on the physics of earthquakes and faulting and she approaches these topics from the perspectives of seismology, rock mechanics, and numerical modeling. Margaret seeks to better understand slip accommodation on oceanic transform faults. Recently she has been delving deeper into the details of earthquake source processes by looking at very small earthquakes in deep gold mines in South Africa.

**Martin Jakobsson** joined JHC/CCOM in August of 2000 as a Post-Doctoral Fellow. Martin completed a Ph.D. at the University of Stockholm where he combined modern multibeam sonar data with historical single-beam and other data to produce an exciting new series of charts for the Arctic Ocean. Martin has been developing robust techniques for combining historical data sets and tracking uncertainty as well as working on developing approaches for distributed database management and Law of the Sea issues. Dr. Jakobsson returned to a prestigious professorship in his native Sweden in April 2004 but remains associated with the Center.

**Kurt Schwehr** received his Ph.D. from Scripps Institution of Oceanography studying marine geology and geophysics. Before joining the Center, he worked at JPL, NASA Ames, the Field Robotics Center at Carnegie Mellon, and the USGS Menlo Park. His research has included components of computer science, geology, and geophysics. He looks to apply robotics, computer graphics, and real-time systems to solve problems in marine and space exploration environments. He has been on the mission control teams for the Mars Pathfinder, Mars Polar Lander, Mars Exploration Rovers and Mars Science Laboratory. He has designed computer vision, 3D visualization, and on-board driving software for NASA's Mars exploration program. Fieldwork has taken him from Yellowstone National Park to Antarctica. At the Center, he worked on a range of projects including the Chart of the Future, visualization techniques for underwater and space applications, and sedimentary geology. He was particularly active in developing hydrographic applications of AIS data. Kurt is Head of Ocean Engineering at Google and an Affiliate faculty in the Center.

**Dave Wells** is world-renowned in hydrographic circles. Dave is an expert in GPS and other aspects of positioning, providing geodetic science support to the Center. Along with his time at UNH, Dave also spends time at the University of New Brunswick and at the University of Southern Mississippi where he is participating in their hydrographic program. Dave also helps UNH in its continuing development of the curriculum in hydrographic training and contributed this spring to a UNH course in Geodesy.

## Visiting Scholars

*Since the end of its first year, the Center has had a program of visiting scholars that allows us to bring some of the top people in various fields to interact with Center staff for periods of between several months and one year.*

**Jorgen Eeg** (October-December 2000) is a senior researcher with the Royal Danish Administration of Navigation and Hydrography and was selected as our first visiting scholar. Jorgen brought a wealth of experience applying sophisticated statistical algorithms to problems of outlier detection and automated cleaning techniques for hydrographic data.

**Donald House** (January-July 2001) spent his sabbatical with our visualization group. He is a professor at Texas A&M University where he is part of the TAMU Visualization Laboratory. He is interested in many aspects of the field of computer graphics, both 3D graphics and 2D image manipulation. Recently his research has been in the area of physically based modeling. He is currently working on the use of transparent texture maps on surfaces.



**Rolf Doerner** (March-September 2002) worked on techniques for creating self-organizing data sets using methods from behavioral animation. The method, called “Analytic Stimulus Response Animation,” has objects operating according to simple behavioral rules that cause similar data objects to seek one another and dissimilar objects to avoid one another.

**Ron Boyd** (July-December 2003) spent his sabbatical at the Center. At the time, Ron was a professor of marine geology at the University of Newcastle in Australia and an internationally recognized expert on coastal geology and processes. He is now an employee of Conoco-Phillips Petroleum in Houston. Ron’s efforts at the Center focused on helping us interpret the complex, high-resolution repeat survey data collected off Martha’s Vineyard as part of the ONR Mine Burial Experiment.

**John Hall** (August 2003-October 2004) also spent his sabbatical from the Geological Survey of Israel at JHC/CCOM. John has been a major player in the IBCM and GEBCO compilations of bathymetric data in the Mediterranean, Red, Black, and Caspian Seas and is working with the Center on numerous data sets including multibeam-sonar data collected in the high Arctic in support of our Law of the Sea work. He is also archiving the 1962 through 1974 data collected from Fletcher’s Ice Island (T-3).

**LCDR Anthony Withers** (July-December 2005) was the Commanding Officer of the HMAS Ships *Leeuwin* and *Melville* after being officer in charge of the RAN Hydrographic School in Sydney, Australia. He also has a Master of Science and Technology in GIS Technology and a Bachelors of Science from the University of South Wales. Lcdr Withers joined us at sea for the Law of the Sea Survey in the Gulf of Alaska and upon returning to the Center focused his efforts on developing uncertainty models for phase-comparison sonars.

**Walter Smith** (November 2005-July 2006) received his Ph.D. in Geophysics from Columbia University’s Lamont-Doherty Earth Observatory in 1990. While at Lamont, he began development of the GMT data analysis and graphics software. From 1990-92, he held a post-doctoral scholarship at the University of California, San Diego’s Scripps Institution of Oceanography in the Institute for Geophysics and Planetary Physics. He joined NOAA in 1992 and has also been a lecturer at the Johns Hopkins University, teaching Data Analysis and Inverse Theory. Walter’s research interests include the use of satellites to map the Earth’s gravity field, and the use of gravity data to determine the structure of the sea floor and changes in the Earth’s oceans and climate.

**Lysandros Tsoulos** (January-August 2007) is an Associate Professor of Cartography at the National Technical University of Athens. Lysandros is internationally known for his work in digital mapping, geoinformatics, expert systems in cartography, and the theory of error in cartographic databases. At the Center, Lysandros worked with NOAA student Nick Forfinski exploring new approaches to the generalization of dense bathymetric data sets.

**Jean-Marie Augustin** (2010) is a senior engineer at the Acoustics and Seismics Department of IFREMER focusing on data processing and software development for oceanographic applications and specializing in sonar image and bathymetry processing. His main interests include software development for signal, data and image processing applied to seafloor-mapping sonars, featuring bathymetry computation algorithms and backscatter reflectivity analysis. He is the architect, designer and main developer of the software suite *SonarScope*.

**Xabier Guinda** (2010) is a Postdoctoral Research Fellow at the Environmental Hydraulics Institute of the University of Cantabria in Spain. He received a Ph.D. from the University of Cantabria. His main research topics are related to marine benthic ecology (especially macroalgae), water quality monitoring and environmental assessment of anthropogenically disturbed sites as well as the use of remote sensing hydroacoustic and visual techniques for mapping of the seafloor and associated communities. His stay at the Center was sponsored by the Spanish government.

**Sanghyun Suh** (2010) is a Senior Research Scientist at the Maritime and Ocean Engineering Research Institute (MOERI) at the Korea Ocean Research and Development Institute (KORDI) in Daejeon, Republic of Korea (South Korea). Dr. Suh received his Ph.D. from the University of Michigan in GIS and Remote Sensing. He worked with Dr. Lee Alexander on e-Navigation research and development (R&D) related to real-time and forecast tidal information that can be broadcast via AIS binary application-specific messages to shipborne and shore-based users for situational awareness and decision-support.

**Xavier Lurton** (August 2010–March 2012) graduated in Physics in 1976 (Universite de Bretagne Occidentale, Brest) and received a Ph.D. in Applied Acoustics in 1979 (Universite du Maine, Le Mans), specializing first in the physics of brass musical instruments. After spending two years of national service as a high-school teacher in the Ivory Coast, he was hired by Thomson-Sintra (the leading French manufacturer in the field of military sonar systems - today Thales Underwater Systems) as a R&D engineer, and specialized in underwater propagation modeling and system performance analysis. In 1989 he joined IFREMER (the French government agency for Oceanography) in Brest, where he first participated in various projects in underwater acoustics applied to scientific activities (data transmission, fisheries sonar, ocean tomography...). Over the years, he specialized more specifically in seafloor-mapping sonars, both through his own technical research activity (both in physical modeling and in sonar engineering) and through several development projects with sonar manufacturers (Kongsberg, Reson); in this context he has participated in tens of technological trial cruises on research vessels. He has been teaching underwater acoustics for 20 years in several French universities, and consequently wrote *An Introduction to Underwater Acoustics* (Springer) widely based on his own experience as a teacher. He manages the IFREMER team specialized in underwater acoustics, and has been the Ph.D. advisor of about 15 students. He spent six months as a visiting scholar at UNH in 2012, working on issues related to sonar reflectivity processing, and bathymetry measurement methods.

**Seojeong Lee** ( April 2012–April 2013) received her Ph.D. in Computer Science with an emphasis on Software Engineering from Sookmyung Women's University in South Korea. She completed an expert course related on Software Quality at Carnegie Mellon University. With this software engineering background, she has worked at the Korea Maritime University as an associate professor since 2005 where her research has been focused on software engineering and software quality issues in the maritime area. As a Korean delegate of the IMO NAV sub-committee and IALA e-NAV committee, she is contributing to the development of e-navigation. Her current research topic is software quality assessment of e-navigation and development of e-navigation portrayal guidelines. Also, she is interested in AIS ASM and improvement of NAVTEX message.

**Gideon Tibor** (April 2012–November 2012) was a visiting scholar from Israel Oceanographic and Limnological Research Institute and the Leon H. Charney School of Marine Sciences in the University of Haifa. Gideon received his Ph.D. in Geophysics & Planetary Sciences from Tel-Aviv University. His main research interest is the development and application of high-resolution marine geophysics and remote sensing using innovative methods in the study of phenomena that influence the marine environment and natural resources. By means of international and local competitive research grants, he uses a multi-disciplinary approach for studying the Holocene evolution of the Levant margin, the Sea of Galilee, and the northern Gulf of Eilat/Aqaba.

## Facilities, IT and Equipment

### Office and Teaching Space

The Joint Hydrographic Center at UNH has been fortunate to have equipment and facilities that are unsurpassed in the academic hydrographic community. Upon the initial establishment of the Center at UNH, the University constructed an 8,000-square-foot building dedicated to the JHC/CCOM and attached to the unique Ocean Engineering high-bay and tank facilities already at UNH. Since that time, a 10,000-square-foot addition has been constructed (through NOAA funding), resulting in 18,000 square feet of space dedicated to JHC/CCOM research, instruction, education, and outreach activities (Figure 1-1).



Figure 1-1. Aerial view of Chase Ocean Engineering Lab and the NOAA/UNH Joint Hydrographic Center. Photo courtesy of Rob Roseen, UNH Stormwater Center.

Of this 18,000 square feet of space, approximately 4,000 square feet are dedicated to teaching purposes and 11,000 square feet to research and outreach, including office space. Our teaching classroom can seat 45 students and has two high-resolution LCD projectors capable of widescreen display. There are 33 faculty or staff offices, four of which are dedicated to NOAA personnel including the NOAA co-director. The new IOCM Data Processing Center has space for an additional nine NOAA personnel, bringing the total space for NOAA personnel to 13, though two of these are currently occupied by NOAA students. The Center has 27 student cubicles (seven of which are for GEBCO students) and we typically have two or three NOAA students. Two additional NOAA cubicles are available for NOAA Marine Operations Center employees at the pier support facility in New Castle (see below).

### Laboratory Facilities

Laboratory facilities within the Center include a map room with light tables, map-storage units and two 60-inch large-format color plotters. Users have the ability to scan documents and charts up to 54 inches using a wide-format, continuous-feed, high-resolution scanner. There are 13 printers positioned throughout the Center including a Canon Pixma Pro 9000 professional photo printer; all computers and peripherals are fully integrated into the Center's network and are interoperable regardless of their host operating system. A computer training classroom consists of fifteen small-form-factor computer systems that were upgraded in 2011, and a ceiling-mounted NEC high-resolution projector. The JHC/CCOM Presentation Room houses the Telepresence Console (Figure 1-2) as well as the Geowall high-resolution multi-display system (Figure 1-3). The IT Group upgraded the Geowall in early 2013, replacing a seven-node Linux cluster with a single Windows 7 system capable of driving all twelve displays. Previously, the Geowall could only be utilized for a single application. In its present form, it can be utilized for multiple purposes, including, but not limited to the display of additional video streams from Telepresence-equipped UNOLS vessels, as well as educational and outreach purposes. The hardware for the Telepresence Console consists of three high-end Dell Precision workstations used for data processing, one Dell multi-display workstation for streaming and decoding real-time video, three 37" Westinghouse LCD displays through which the streams are presented, and a voice over IP (VoIP) communication device used to maintain audio contact with all endpoints. The multi-display Dell workstation provides MPEG-4 content streaming over Internet2 from multiple sources concurrently. All systems within the Presentation Room are connected to an Eaton Powerware UPS to protect against power surges and outages. In 2013, JHC/CCOM used the Telepresence Console to participate in research programs with the NOAA Ship *Okeanos Explorer* and URI's E/V *Nautilus* on their respective cruises. The JHC/CCOM Video Classroom provides for web conferencing, remote teaching, and the hosting of webinars.

The IT Group collaborates with the JHC/CCOM seminar organizers to provide both live webinar versions of the JHC/CCOM Seminar Series, as well as video and audio archives available through the web after each event and distribution of the finished products through the JHC/CCOM website, Vimeo, and YouTube.





Figure 1-2. The Telepresence Console.

Our Visualization Lab includes an ASL eye-tracking system and a new immersive display that was inspired by, and expands upon, Google’s Liquid Galaxy system. The display is made up of five, 60 inch, vertically mounted LED monitors that are arranged in 120 degree arc (Figure 1-4). This new display and its applications will be discussed further in the Visualization section of the report. The Visualization lab also has a custom multi-touch stereoscopic viewing environment for visualizing oceanographic flow model output, force-feedback and six-degree-of-freedom tracking devices, and a Minolta LS-100 luminance meter. We have also built a lidar simulator lab, providing a secure and safe environment in which to perform experiments with our newly constructed lidar simulator. The Center also maintains a full suite of survey, testing, electronic, and positioning equipment.

The Center is co-located with the Chase Ocean Engineering Lab. Within the Chase Ocean Engineering Lab is a high-bay facility that includes extensive storage and workspace in a warehouse-like environment. The high bay consists of two interior work bays and one exterior work bay with power, lights, and data feeds available throughout. A 5000-lb. capacity forklift is available.

Two very special research tanks are also available in the high bay. The wave/tow tank is approximately 120 ft. long, 12 ft. wide and 8 ft. deep. It provides a 90-ft. length in which test bodies can be towed, subjected to wave action, or both. Wave creation is possible using a hydraulic flapper-style wave-maker that can produce two-to-five second waves of maximum amplitude approximately 1.5 feet. Wave absorption is provided by a saw-tooth style geo-textile construction that has an

average 92% efficiency in the specified frequency range. The wave-maker software allows tank users to develop regular or random seas using a variety of spectra. A user interface, written in LabView, resides on the main control station PC and a wireless LAN network allows for communication between instrumentation and data acquisition systems. In 2013, the tow system was upgraded to improve smoothness of operation and increased stability at all speeds. Transient signals have been reduced significantly so that slow speed/low force projects are feasible. Data acquisition has been vastly improved with 32 channels of analog input, 4 channels of strain measurement, and Ethernet and serial connectivity all routed through shielded cabling to the main control computer. Power is available on the carriage in 120 or 240 VAC.

The engineering tank is a freshwater test tank 60 ft. long by 40 ft. wide with a nominal depth of 20 ft. The 380,000 gallons that fill the tank are filtered through a 10-micron sand filter twice per day providing an exceptionally clean body of water in which to work. This is a multi-use facility hosting the UNH SCUBA course, many of the OE classes in acoustics and buoy dynamics, as well as providing a controlled environment for research projects ranging from AUVs to zebra mussels. Mounted at the corner of the Engineering Tank is a 20-foot span, wall-cantilevered jib crane. This crane can lift up to two tons with a traveling electric motor controlled from a hand unit at the base of the crane. In 2003, with funding from NSF and NOAA, an acoustic calibration facility was added to the engineering tank. The acoustic test-tank facility is equipped to do standard measurements for hydrophones, projectors, and sonar systems. Common measurements include transducer impedance,



Figure 1-3. The Geowall Display at the Joint Hydrographic Center.



Figure 1-4. Semi-immersive, large-format tiled display.

free-field voltage sensitivity (receive sensitivity), transmitting voltage response (transmit sensitivity), source-level measurements and beam patterns. The standard mounting platform is capable of a computer-controlled full 360-degree sweep with 0.1 degree resolution. We believe that this tank is the largest acoustic calibration facility in the Northeast and is well suited for measurements of high-frequency, large-aperture sonars when far-field measurements are desired. In 2013, the engineering tank had 229 days of use. In partnership with OER, a six-ton capacity crane was added to the high-bay this year, allowing the deployment of the OER Deep Discover Remotely Operated Vehicle (ROV) and other heavy items in to the test tank.

Several other specialized facilities are available in the Chase Ocean Engineering Lab to meet the needs of our researchers and students. A 750 sq. ft., fully equipped electronics lab provides a controlled environment for the design, building, testing, and repair of electronic hardware. A separate student electronics laboratory is available to support student research. A 720 sq. ft. machine shop equipped with a milling machine, a tool-room lathe, a heavy-duty drill press, large vertical and horizontal band saws, sheet metal shear and standard and arc welding capability are available for students and researchers. A secure facility for the development and construction of a state-of-the-art ROV system was built for our collaboration with NOAA's Ocean Exploration Program. A 12 ft. x 12 ft. overhead door facilitates entry/exit of large fabricated items. A master machinist/engineer is on staff to support fabrication activities.

## Pier Facilities

In support of the Center and other UNH and NOAA vessels, the University recently constructed a new pier facility in New Castle, NH. The new pier is a 328 ft. long and 25 ft. wide concrete structure with approximately 15 ft. of water alongside. The pier can accommodate UNH vessels and, in 2013, became the homeport for the new NOAA Ship *Ferdinand R. Hassler*, a 124-ft. LOA, 60-ft. breadth, Small Waterplane Area Twin Hull (SWATH) Coastal Mapping Vessel (CMV), the first of its kind to be constructed for NOAA. Services provided on the new pier include 480V-400A and 208V- 50A power with TV and telecommunications panel, potable water and sewerage connections. In addition to the new pier, the University constructed a

new pier support facility with approximately 4,500 sq. ft. of air-conditioned interior space including offices, a dive locker, a workshop, and storage. Two additional buildings (1,100 sq. ft. and 1,300 sq. ft.) are available for storage of the variety of equipment and supplies typically associated with marine operations

## Information Technology

The IT Group currently consists of three full-time staff members (down one from 2012) and two part-time help desk staff. Jordan Chadwick fills the role of Systems Manager and deals primarily with the day-to-day administration of the JHC/CCOM network and server infrastructure. He is also responsible for leading the development of the Information Technology strategy for the Center. The Systems Administrator, William Fessenden, is responsible for the administration of all JHC/CCOM workstations and backup systems. In addition, William serves as Jordan's backup in all network and server administration tasks and contributes to the planning and implementation of new technologies at the Center. Paul Johnson, JHC/CCOM's Data Manager, is responsible for organizing and cataloging the Center's vast data stores. Paul is currently exploring different methods and products for managing data, and verifying that all metadata meet industry and Federal standards.

IT facilities within Chase Ocean Engineering Lab consist of two server rooms, a laboratory, the Presentation Room, Computer Classroom, and several staff offices.

The server room in the south wing of the building is four times larger than its counterpart in the north wing, and has the capacity to house 14 server racks. This space, combined with the north-wing server room, give JHC/CCOM's data centers the capacity to house 20 full-height server racks. Both server rooms are equipped with redundant air conditioning, temperature and humidity monitoring and FE-227 fire suppression systems. These systems help to ensure that JHC/CCOM network services have as little downtime as possible. Additionally, the larger of the server rooms employs a security camera, as well as a natural gas powered generator to provide power in the event of a major outage. The IT lab provides ample workspace for the IT Group to carry out its everyday tasks and securely store sensitive computer equipment. The IT staff offices are located adjacent to the IT lab.

All JHC/CCOM servers, storage systems, and network equipment are consolidated into nine full height cabinets with one or more Uninterruptible Power Supplies (UPS) per cabinet. At present, there is a total of 21 physical servers, 25 virtual servers, two NetApp storage systems fronting eight disk arrays, and the compute cluster consisting of seven nodes. A CheckPoint Firewall and Intrusion Prevention System and a CheckPoint logging and management server provide boundary protection for our 10-gigabit and gigabit Local Area Network (LAN). JHC/CCOM also hosts five dedicated servers for NOAA's nowCOAST Web Mapping Portal, which mirror the primary nowCOAST web and database servers, currently hosted in Silver Spring, MD.

At the heart of the JHC/CCOM's network lies its robust networking equipment. A Dell/Force10 C300 switch serves as the core routing and switching device on the network. It is currently configured with 192 gigabit Ethernet ports, all of which support Power over Ethernet (PoE), as well as 24 10-gigabit Ethernet ports. The 10-gigabit ports provide higher-throughput access to network storage and the Center's computer cluster. In early 2013, the IT Group replaced the Foundry Big Iron RX-8 that served the south wing with a Brocade ICX 6610 switch stack which provides 192 gigabit Ethernet ports for workstation connectivity and 32 10-gigabit Ethernet ports, to be used for access to the network backbone as well as for certain workstations needing high-speed access to storage resources. These core switching and routing systems are supplemented with several edge switches, consisting of a Dell PowerConnect 2924 switch, four Brocade 7131N wireless access points centrally managed with a Brocade RFS4000 management device, and a QLogic SANBox 5800 Fibre Channel switch. The PowerConnect switch handles

edge applications such as the Center's Electronics Laboratory and the Telepresence Console. The SANBox 5800 provides Fibre Channel connectivity to the Storage Area Network for backups and high-speed server access to storage resources. The C300 PoE ports power the wireless access points as well as the various Axis network cameras used to monitor physical security in the Lab. The Brocade wireless access points provide wireless network connectivity for both employees and guests. Access to the internal wireless network is secured through the use of the 802.1x protocol utilizing the Extensible Authentication Protocol (EAP) to identify wireless devices authorized to use the internal wireless network.

Increasing efficiency and utilization of server hardware at JHC/CCOM remains a top priority. The Center has set out to virtualize as many servers as possible, and to use a "virtualize-first" method of implementing new servers and services. To this end, the IT staff utilizes a three host VMware ESXi cluster managed as a single resource with VMware vSphere. The cluster utilizes VMware High Availability and vMotion to provide for a flexible platform for hosting virtual machines. All virtual machines in the cluster are stored in the Center's high-speed SAN storage system, which utilizes snapshots for data protection and duplication for storage efficiency. An additional VMware ESXi host serves as a test platform. Together, these systems house 25 virtual servers at present, and plans are in place to virtualize more servers as current physical servers reach the end of their hardware lifecycle. Current virtual machines include the JHC/CCOM email server, Visualization Lab web server, Certification Authority server, several Linux/Apache web servers, a Windows Server 2008 R2 domain controller, version control server, two JIRA project management servers, a FTP server, and an Oracle database server.

The Center's storage area network (SAN) systems currently consist of a NetApp FAS3240 cluster, and a NetApp FAS3140 storage appliance. The FAS3240 currently hosts 128 terabytes (TB) of raw storage and is capable of expanding to nearly two petabytes (PB). The FAS3240 also supports clustered operation for failover in the event of system failure, block-level de-duplication to augment efficiency of disk usage, and support for a number of data transfer protocols, including iSCSI, Fibre Channel, NFS, CIFS, and NDMP. Migration of data from the old FAS960c storage system to the new FAS3240 was completed in December of 2012. In addition to the FAS3240, the purchase also included a FAS3140 SAN filer provided as a charitable donation by NetApp. Several disk shelves from the old FAS960c were migrated to the FAS3140 system to extend their



useful lifetime. Center IT staff also built, configured, and installed a custom-built locally-redundant storage system hosting over 54TB of data as a middle-tier storage system in the first quarter of 2013. This storage system is used to supplement the NetApp SAN by moving less critical datasets onto a less expensive medium. IT Staff utilizes Microsoft's Distributed File System (DFS) to organize all SAN data shares logically by type. In addition to DFS, a custom metadata cataloging web application was developed to make discovering and searching for data easier for both IT Staff and the Center as a whole.

Constantly increasing storage needs create an ever-increasing demand on JHC/CCOM's backup system. To meet these demands, the IT Group utilizes a CommVault Simpana backup solution that consists of two backup servers, three media libraries, and backup control and management software. The system provides comprehensive protection for workstation, server, and storage systems. The system utilizes de-duplicated disk-to-disk backup in addition to magnetic tape backup, providing two layers of data security and allowing for more rapid backup and restore capabilities. For magnetic tape backup, the IT Group utilizes a Quantum i40 LTO5 tape library, capable of backing up 120TB of data without changing tapes, which, combined with Simpana's NDMP backup capabilities, allow for the backup of data on the FAS3240 and FAS3140 SANs directly over Fibre Channel. A Quantum Scalar50 LTO4 tape library is responsible for the backup of all JHC/CCOM primary workstations and servers.

The JHC/CCOM network is protected by a CheckPoint 4810 security gateway. This device serves as a Unified Threat Management (UTM) platform, able to protect against multiple threat vectors with firewall, intrusion prevention, anti-virus, anti-spam, application-level control, and URL filtering modules. The system also serves as a mobile access gateway, providing SSL VPN access. With the mobile access solution, users are able to join their local computer to the JHC/CCOM network from anywhere in the world, allowing them to use many of JHC/CCOM's network-specific resources on their local computer. The system also includes a management appliance that performs log filtering, searching, archiving, and network event correlation.

JHC/CCOM employs a Dell computer-cluster for resource-intensive data processing. The cluster utilizes seven Dell blade servers running Microsoft Windows HPC Server 2008 R2. This allows the Center to harness the computing power of 56 CPU cores and over 50GB of RAM as one logical system, reducing the amount

of time it takes to process datasets. This also frees up scientists' workstations while the data is processed, allowing them to make more efficient use of their time. JHC/CCOM evaluated and purchased MATLAB Distributed Computing Server for HPC in 2011, and is in the process of developing a next-generation, parallel-processing software system with consortium partners.

The Center has continued to upgrade end users' primary workstations, as both computing power requirements, and the number of employees and students have increased. There are currently 206 high-end Windows and Linux desktops/laptops, as well as 26 Apple Mac OSX computers that serve as faculty, staff, and student workstations. As of the end of 2013, Windows XP has almost entirely been phased-out of the computing environment in preparation for its end-of-support deadline in April 2014. Additionally, Mac users are also being upgraded to the latest version of the OSX operating system, 10.9. Deploying the 64-bit version of these operating systems allows faculty, staff and students to take advantage of new, enhanced versions of scientific and productivity software, while maintaining interoperability with older applications.

The Center maintains a network at the Pier Support Building at UNH's Coastal Marine Lab facility in New Castle, NH. The JHC/CCOM network is extended through the use of a Cisco ASA VPN device. This allows for a permanent, secure network connection over public networks between the support building and Center's main facility at Chase Lab on the UNH campus. The VPN connection allows the IT Group to easily manage JHC/CCOM systems at the facility using remote management and, conversely, systems at the facility have access to resources at Chase Lab. Both of the JHC/CCOM research vessels are located at the pier adjacent to the Pier Support Building. The IT Group maintains computer systems and local networks on both the R/V *Coastal Surveyor* and the R/V *Cochecho*. Both launches also have access to wireless network connectivity through the Coastal Marine Lab. The *Coastal Surveyor's* systems were upgraded in 2010, and the *Cochecho's* systems will be upgraded in 2014.

In September of 2013, UNH received a grant from the National Science Foundation intended to improve campus cyber infrastructure. The express intent of the grant is to improve bandwidth and access to Internet2 resources for scientific research. JHC/CCOM was identified in the grant as a potential beneficiary of such improved access. The project is currently in the planning stages, but when completed, the Center will have a 20-gigabit connection to UNH's Science DMZ,

and from there, a 10-gigabit connection to Internet2. This improvement will allow researchers at the Center to collaborate with NOAA and other partners through the use of high-bandwidth data transfers, streaming high-definition video, and other bandwidth intensive applications. The network improvements are scheduled for installation and testing in the summer of 2014, and will be operating in a production capacity by the end of 2014.

Information security is of paramount importance for the IT Group. Members of the JHC/CCOM staff have been working with OCS IT personnel to develop and maintain a comprehensive security program for both NOAA and JHC/CCOM systems. The security program is centered on identifying systems and data that must be secured, implementing strong security baselines and controls, and proactively monitoring and responding to security incidents. Recent measures taken to enhance security include the installation of a multifaceted threat management system, which allows the IT Group to monitor and respond to malicious network traffic more efficiently. JHC/CCOM utilizes Avira AntiVir antivirus software to provide virus and malware protection on individual servers and workstations. Avira server software allows for centralized monitoring and management of all Windows and Linux systems on the JHC/CCOM network, including the Center's email server. The AntiVir solution is supplemented by Microsoft ForeFront EndPoint Protection for systems dedicated to field work that do not have the ability to check-in with the management server on a periodic basis. Microsoft Windows Server Update Services (WSUS) is used to provide a central location for JHC/CCOM workstations and servers to download Microsoft updates. WSUS allows the IT staff to track the status of updates on a per-system basis, greatly improving the consistent deployment of updates to all systems.

In an effort to tie many of these security measures together, the IT Group utilizes Nagios for general network and service monitoring. Nagios not only provides for enhanced availability of services for internal JHC/CCOM systems, it also has been a boon for external systems that are critical pieces of several research projects, including AIS ship tracking for the U.S. Coast Guard. The same server that hosts Nagios also runs a Syslog server as a central repository for system logs, and utilizes custom-built modules for event identification and report generation to meet a variety of additional logging needs. The installation of a biometric door access system, which provides 24/7 monitoring and alerting of external doors and sensitive areas within the facility, was completed in the first quarter of 2013

and has greatly improved the physical security of Chase Ocean Engineering Lab in general, with emphasis on sensitive IT areas.

All information security controls at JHC/CCOM are independently assessed on a regular basis. Assessment reports, along with related documentation, are compiled into an Assessment and Accreditation package and submitted to NOAA's Office of Coast Survey. The package demonstrates JHC/CCOM's compliance with the Department of Commerce's Information Technology Security Program Policy, as well as the host of NIST standards that form the foundation of the Policy.

The IT Group utilizes Request Tracker, a helpdesk ticket tracking software published by Best Practical. JHC/CCOM staff, students, and faculty have submitted over 5000 Request Tracker tickets since its inception in mid-2009. Throughout 2013, the IT Staff was able to resolve 90% of tickets within three days. The software is also used for issue tracking by the JHC/CCOM administrative staff, lab and facilities support team, web development team, and scientists supporting the NSF Multibeam Advisory Committee project.

JHC/CCOM continues to operate within a Windows Active Directory domain environment, and in early 2012, migrated the majority of its domain services to 2008 Active Directory running on Windows Server 2008 R2. A functional 2008 domain allows the IT Group to take advantage of hundreds of new security and management features available on Windows 7 and Windows 8 operating systems. The Windows 2008 Active Directory servers also provide DHCP, DNS, and DFS services. Policies can be deployed via Active Directory objects to many computers at once, thus reducing the IT administrative costs in supporting workstations and servers. This also allows each member of the Center to have a single user account, regardless of computer platform and/or operating system, reducing the overall administrative cost in managing users. In addition, the JHC/CCOM IT Group maintains all low and moderate impact NOAA computers in accordance with OCS standards. This provides the NOAA-based employees located at the JHC with enhanced security and data protection.

JHC/CCOM currently utilizes two separate version control mechanisms on its version control virtual server—Subversion (SVN) and Mercurial (Hg). The Mercurial system went online in 2011 and, presently, the JHC/CCOM IT Group encourages developers to use Mercurial for new projects, while continuing to support Subversion for existing projects. Mercurial uses a decentralized architecture which is less reliant on a central

server, and also permits updates to repositories without direct communication to that server. This allows users in the field to continue software development while still maintaining version history. The IT Group hosts a Jira software project management server to aid in tracking bugs and new features for software projects.

JHC/CCOM also utilizes Bitbucket to facilitate software collaboration between its own members as well as industrial partners and other academic colleagues. Bitbucket is a source control management solution that hosts Mercurial and Git software repositories. Atlassian, the company behind Bitbucket, states that Bitbucket is SAS70 Type II compliant and is also compliant with the Safe Harbor Privacy Policy put forth by the US Department of Commerce.

The JHC/CCOM website, re-launched in 2012, utilizes the Drupal content management system as its framework. Drupal allows for content providers within the Center to make changes and updates without the assistance of a web developer. The flexibility of the framework was utilized for the creation of a data content portal, which can dynamically serve any dataset hosted through JHC's ArcGIS Server. Additionally, the website offers a more robust platform for multimedia and other rich content, as well as a polished look and feel.

Work continues on the development of Center-wide Intranet services using the Drupal content management software. The Intranet provides a centralized framework for a variety of information management tools, including the Center's wiki, inventory, purchase tracking, library, data catalog, and progress reporting systems. The progress reporting system is entering its third reporting period and has greatly improved the efficiency and completeness of the Center's annual report. Additionally, development continues on the Center's ArcGIS server. As this resource evolves, more Intranet services will be brought online to assist in the search for Center-hosted data and access to this data through Intranet-based mapping services.



Figure 1-5. Research vessels at the pier in New Castle, NH.

## Research Vessels

The Center operates two dedicated research vessels (Figures 1-6 and 1-8), the 40-foot R/V *Coastal Surveyor* (JHC/CCOM owned and operated) and the 34-foot R/V *Cocheco* (NOAA owned and JHC/CCOM maintained and operated). In 2013, the *Coastal Surveyor* operated for ten months (April through December) with much of its operation focused on collecting data in support of the Summer Hydrography Field Course and the NEWBEX experiment (see the Backscatter Uncertainty discussion under the Data Processing theme). The *Coastal Surveyor* is often used by our industrial partners to test their sonar systems over the well-known Portsmouth Harbor Shallow Survey Common Data Set field area. The *Cocheco* operated for five months, focusing on over-the-side operations such as deploying buoys and bottom-mounted instruments, bottom sampling, and towing instruments. This will be the fifth year that both vessels will be left in the water over the winter at the UNH pier facility in New Castle and will be the first year that we attempt to operate the vessels year-round in support of the NEWBEX Experiment. Winter mooring has reduced the winter costs and added the advantage that the vessels are at the ready throughout the entire year. The vessels are operated primarily in the area of Portsmouth, NH, but are capable of transiting and operating from Maine to Massachusetts. Neither vessel is designed for offshore operations; they are ideally suited to near-shore and shallow water (in as little as four meters depth).

The vessels are operated under all appropriate national and international maritime rules as well as the appropriate NOAA small boat rules and those of the University of New Hampshire. Both boats carry life rafts and EPIRBs (Emergency Position Indicating Radio Beacons), electronic navigation systems based on GPS, and radar. Safety briefings are given to all crew, students, and scientists. Random man-overboard and emergency towing exercises are performed throughout the operating season. The Center employs two permanent captains.

In addition to the two research vessels, the Center also has a personal watercraft equipped with differential GPS, single-beam 192-kHz acoustic altimeter, multibeam sonar system, ADCP, and onboard navigation system (CBASS—see Sensors discussion) and has partnered with the Blodgett Foundation to help equip a hovercraft (R/H *Sabvabba*) specially outfitted to work in the most extreme regions of the Arctic (see Sensors discussion).



**R/V Coastal Surveyor**

(40 ft. LOA, 12 ft. beam, 5.5 ft. draft, cruising speed of 9 knots)

The *Coastal Surveyor* (Figure 1-6) was built by C&C Technologies (Lafayette, LA) approximately thirty years ago on a fiberglass hull design that had been used for U.S. Navy launches. She was built specifically for the purpose of collecting multibeam sonar data, and has a bow ram for mounting sonar transducers without hauling the vessel (Figure 1-7). C&C operated the *Coastal Surveyor* for a decade and a half, then made a gift of her to JHC/CCOM in 2001. She has become a core tool for JHC/CCOM's operations in New Hampshire and continues to be invaluable to the Center. Thanks to improved hydraulic stabilizers (in 2005), the high precision of boat offset surveys and the remarkably stable transducer mount, she remains one of the finest shallow-water survey vessels in the world. A marine survey was completed in 2008, acknowledging that the vessel is sound but beginning to show her age. The main engine, a 200 BHP Caterpillar diesel with over five thousand hours, although running reliably, does not run efficiently. Minor electrical and plumbing issues were identified in the survey and were addressed. In 2010, the ship's AIS transponder and a new Simrad AP28 autopilot were installed and the HVAC seawater pump and manifold and engine room bilge pump were also replaced. In 2011, the Isuzu-powered 20 kilowatt generator terminally failed and was replaced with a 12 kilowatt Northern Lights generator. Additionally, the degraded engine room soundproofing was replaced along with the hydraulic steering piston and several hydraulic hoses. In 2012, leaking hatches, caulking and gaskets were replaced and, in 2013, along with regular maintenance (e.g., painting, cleaning etc.), the POS/MV antennae were replaced and a new AIRMAR weather sensor, a new navigation transducer, and a pier-side webcam were installed.



Figure 1-7. R/V Coastal Surveyor's bow ram lowered.



Figure 1-6. R/V Coastal Surveyor with bow ram.

**R/V Coastal Surveyor Scheduled Research and Educational Operations for 2013**

Month	Days	User
April	2	Other (Maintenance)
May	5	NEWBEX
May	1	ARGUS
June	13	Summer Hydro
June	4	NEWBEX
June	1	L3-Klein
June	2	Maintenance
July	3	Marcroalgae
July	5	NEWBEX
July	4	Training and Maintenance
July	1	L3-Klein
August	6	NEWBEX
August	2	L3-Klein
August	2	NOAA's Klein 5400
September	4	ODOM-MB-1
September	6	NEWBEX
September	1	Eelgrass Survey
September	2	Training and Maintenance
September	1	UNH Police search
October	6	NEWBEX
November	4	NEWBEX
November	1	L3-Klein
December	4	NEWBEX

**R/V Cocheco**

(34 ft. LOA, 12 ft. beam, 5.5 ft. draft, cruising speed of 16 knots)



Figure 1-8. R/V Cocheco.

R/V Cocheco (Figure 1-8) was designed for fast transits and for over-the-stern operations from her A-frame. Several years ago, a hydraulic system and winch equipped with a multiconductor cable were installed making the vessel suitable for deploying or towing a wide variety of samplers or sensors. Upgrades to the UPS-power system, wiring for 220 VAC, and instrument bench wiring for both 24 VDC and 12 VDC were also completed.

In 2009, AIS was permanently installed on Cocheco, her flux-gate compass was replaced, and improvements made to her autopilot system. In addition, Cocheco's 12 VDC power system, hydraulic system wiring and communications wiring were updated. In 2010, a second VHF radio and antenna was installed and several battery banks were replaced and upgraded.

This past year, the Cocheco had an extended yard period that, in addition to the annual maintenance, included engine maintenance to improve performance and limit oily exhaust, repairs to the hydraulic steering system, and replac-

ing the non-skid paint on the aft deck. This winter's maintenance is currently being planned. In addition, a contract has been approved for adding a multibeam sonar mount to Cocheco with the scheduling for this installation being worked out with the contractor.

**R/V Cocheco Scheduled Research and Educational Operations for 2013**

Month	Days	User
May	1	Seamanship Course - buoy operations
June	23	Summer Hydrographic Field Course –SBES, MVP, grab sampling, U/W video,
July	1	NEWBEX – grab sampling, U/W video
July	5	ARGUS work
September	1	Ocean Discovery Day



Figure 1-9. R/V Cocheco off the starboard bow.



Figure 1-10. Cocheco's A-frame.

R/H *Sabvabaa*

Dr. John K. Hall, a visiting scholar at the Center in 2003 and 2004, has been instrumental in the construction of a hovercraft designed to support mapping and other research in the most inaccessible regions of the high Arctic. The construction of the hovercraft, a 13m-long Griffon 2000T called the R/H *Sabvabaa* (Figure 1-11), was underwritten by Dr. Hall’s family foundation, the Blodgett Foundation. The vessel has operated out of UNIS, a University Centre in Longyearbyen, Svalbard, since June 2008 under the supervision of Professor Yngve Kristoffersen of the University of Bergen. Through donations from the Blodgett Foundation, the Center provided a Knudsen 12-kHz echosounder, a four-element Knudsen CHIRP sub-bottom profiler and a six-channel streamer for the *Sabvabaa*. Using a 20 to 40 in<sup>3</sup> airgun sound source, the craft is capable of profiling the shallow and deep layers over some of the least studied and most interesting areas of the ice-covered Arctic—areas that are critical to understanding the origin and history of the Arctic Ocean.



Figure 1-11. R/H *Sabvabaa* measuring wave swell spectra on Yermak Plateau.



Figure 1-13. R/H *Sabvabaa* with 7 m-long dart corer. Note the hovercraft’s ability to operate even on very small floe.

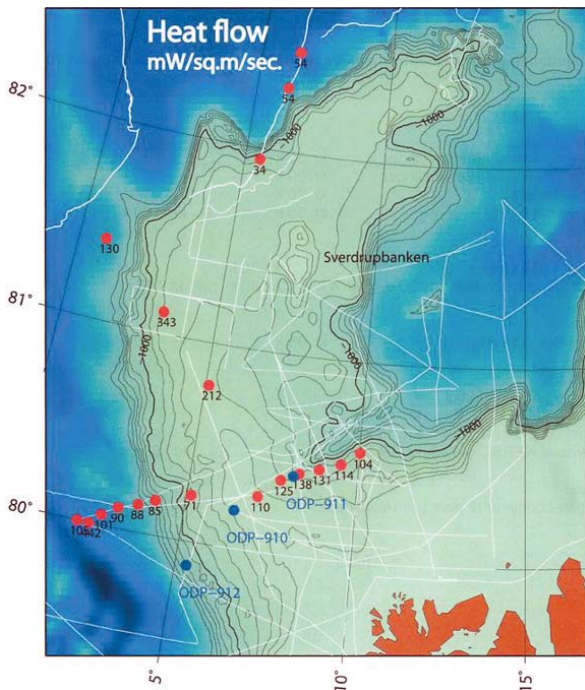

Figure 1-12. R/H *Sabvabaa* heat flow stations on Yermak Plateau in 2013.

In 2012, the *Sabvabaa* spent ten weeks on the ice, including more than five weeks monitoring some 300 earthquakes on the Gakkel Ridge. In 2013, *Sabvabaa* embarked on two expeditions. The first involved ten days on the ice on the Yermak Plateau between 80°N and 82°N measuring the damping of ocean swell with

distance from the ice edge (Figure 1-11) and collecting heat flow measurements using a 7-m long free-fall dart corer equipped with thermistor outriggers (Figures 1-12 and 1-13).

The second expedition involved the deployment of the *Sabvabaa* from the Norwegian naval icebreaker K/V *Svalbard*. Operating as a satellite platform from the *Svalbard*, the *Sabvabaa* took part in the UNDER-ICE-2013 experiment involving an international team deploying numerous ice buoys as well as making acoustic and CTD measurements (Figure 1-14). While a broken clutch eventually disabled the *Sabvabaa*, the successful deployments from the *Svalbard* demonstrated the value of the hovercraft as a support vehicle for larger ice-breakers.



Figure 1-14. K/V *Svalbard* with R/H *Sabvabaa* deployed over the side during the UNDER-ICE-2013 experiment.



NOAA ROV

The 2010 NOAA cooperative agreement includes a much closer and formalized collaboration with the NOAA's Office of Ocean Exploration and Research (OER). As part of this collaboration, the OER program has chosen to use the facilities of the Center as the staging area for the development of their new deep-water Remotely Operated Vehicle (ROV). In support of this effort, the Center has constructed a large, secure work area in proximity to our deep acoustic test tank so that as development is underway, components or the entire system can be tested in the tank (Figures 1-15 and 1-16).

The NOAA ROV system is a two vehicle system—the ROV and a camera sled. The ROV is connected to a camera sled via a flexible electro-optical tether that is, in turn, connected to the support vessel via a standard oceanographic 0.68" armored electro-optical-mechanical cable. Each vehicle carries separate subsea computers, high-definition (HD) cameras and Hydrargyrum Medium-Arc Iodide (HMI) lighting. Each is controlled independently of the other from a topside control system. The 9200 lb. ROV operates in a traditional manner, employing a large-array of LED lights, six cameras, two seven-function manipulators, thrusters, and other science equipment to explore its surroundings. The camera sled serves three primary purposes: to decouple the ROV from any ship movement, provide an alternative point of observation for ROV operations and to add substantial back-lighting for the ROV imaging. Both systems are rated for operations down to 6000 meters.



Figure 1-15. *Deep Discoverer* ROV being constructed in the Center's high-bay.

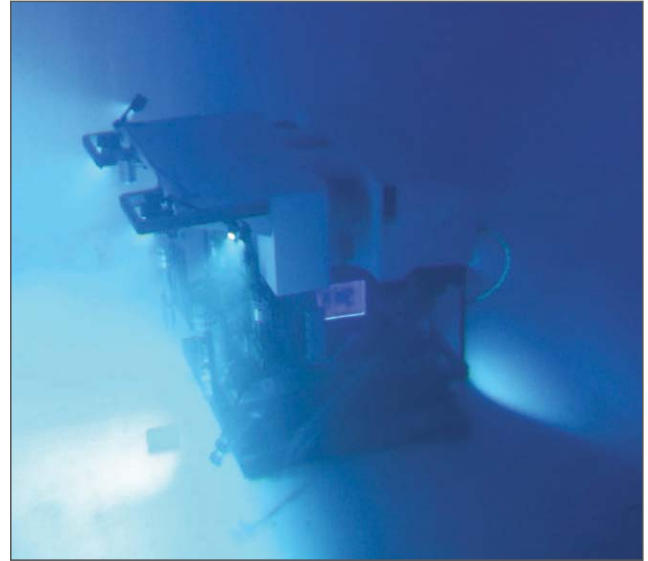

Figure 1-16. *Deep Discoverer* ROV being tested in Ocean Engineering test tank at the Center

In 2011, the camera sled (christened *Seirios*) was constructed at the Center. The Center directly supported the NOAA team in the construction of the sled through machining of parts, assembly of the sled, and supporting testing in the Engineering Tank. *Seirios* was fully tested in the lab and deployed on the NOAA Ship *Okeanos Explorer* where it worked successfully for the entire 2011 season. In 2012, construction of the ROV (now called *Deep Discoverer*) began and by early 2013 it was ready for initial testing. A new 6-ton capable lifting gantry system was installed in the high-bay that allowed for moving the vehicle directly from the work area into the acoustic engineering tank. The ability to work on the ROV in the high-bay and easily place it in the acoustic engineering tank for testing greatly facilitated the completion of the ROV allowing it to be sent to the *Okeanos Explorer* for field testing in April 2013 and to commence mission operations in May.

## Educational Program

### Curriculum Development

At its inception, the Center, under the guidance of Capt. Armstrong, developed an ocean-mapping-specific curriculum that was approved by the University and certified (in May 2001) as a Category A program by the FIG/IHO/ICA International Advisory Board for Standards of Competence for Hydrographic Surveyors. The Center also established a post-graduate certificate program in Ocean Mapping with a minimum set of course requirements that can be completed in one year. This allows post-graduate students who cannot spend the minimum of two years necessary to complete a master's degree the means to upgrade their education and receive certification of completion of the course work.

Although our students have a range of general science and engineering courses to complete as part of the Ocean Mapping Program, the Center teaches several courses specifically designed to support the Ocean Mapping Program. In response to our concern about the varied backgrounds of the students entering our program, we have collaborated with the Dean of the College of Engineering and Physical Sciences and the Department of Mathematics and Statistics to create a specialized math course, taught at the Center. This course is designed to provide Center students with a background in the math skills needed to complete the curriculum in Ocean Mapping. The content of this course was designed by Semme Dijkstra and Brian Calder specifically to address the needs of our students and is taught by professors from the UNH Math Department. In 2008, in recognition of the importance of our educational program, we created the position of full-time instructor in hydrographic science. Semme Dijkstra, who led the effort to revamp our curriculum and renew our FIG/IHO/ICA Cat. A certification (see below), fills this position.

The original FIG/IHO Certification received by the Center at its inception required renewal in 2011 and, in light of the need for a new submission to the FIG/IHO/ICA, the extraordinary growth of the Center (and expansion of faculty expertise), and the recognition that certain aspects of our curriculum were leading to unrealistic demands on our students, the Center, under the leadership of Semme Dijkstra, re-designed the entire ocean mapping curriculum.

The goals of the new curriculum were to:

- Reduce the number of required credit hours for our certificate students,

- Create a keystone, two-semester “Fundamentals of Ocean Mapping” course that would cover all the fundamentals defined by the members of our faculty and the IHO/FIG/ICA,
- Take broad advantage of the expertise available at JHC/CCOM,
- Meet the standards required for FIG/IHO Category A certification, and
- Be modular so that components may be taught on their own at the Center or other locations.

This curriculum was presented to the FIG/IHO/ICA education board by Dijkstra and Capt. Armstrong and was accepted (the board lauded the UNH submission as “outstanding”). Thus, the Center maintains an IHO Category A Certification and continues to be one of only two Category A programs available in North America. The new curriculum (Appendix A) has subsequently been accepted by the College of Engineering and Physical Sciences curriculum committee, approved by the graduate school, and was presented for the first time in 2012.

Initial feedback from students has been good. However, suggestions for improvements were made and, in the academic year 2012-2013, Dijkstra focused on providing the students with a better understanding of the context and order of presentation for each of the teaching modules. A remaining challenge is to better integrate practical exercises within the curriculum. To achieve this goal, Dijkstra is working on two sets of practice exercises—the continued development of the “Tools for Ocean Mapping” course that was completely overhauled in academic year 2012-2013, and the development of a Virtual Ocean Mapping Assignment similar in nature to the existing Virtual GNSS assignment (which was also updated significantly this year). It is expected that the rollout for this set of exercises will take place in the fall of 2014.

“Tools for Ocean Mapping” is now a 21-step practical assignment. As part of this assignment, the students combine data for various data sources including bathymetry, DTMs, video, etc., into a single GIS database and learn to process and manipulate the data (e.g., changing datums) using a variety of software tools. As part of this process, the students need to evaluate various coordinate reference frames used for the data acquisition and QA/QC the data. This exercise involves extensive use of ArcGIS, data manipulation in Excel, programming in Matlab, creating Windows terminal

scripts and Ubuntu Linux scripts. Finally, the students have to use these data to plan future data collection using Hypack, and present the data using the Generic Mapping Tools. New in 2013 were the tighter integration of 3D visualization tools, the inclusion of a scientific writing assignment, and preparation of a poster highlighting the data and tools used in the course.

Thirty-two full-time students are currently enrolled in the Ocean Mapping program (see listing below), including six GEBCO students, two NOAA Corps officers and two NOAA physical scientists. We have produced five Ph.D.s: Luciano Fonseca (2001); Anthony Hewitt (2002); Matt Plumlee (2004); Randy Cutter (2005); and Dan Pineo (2010). This past year, we graduated two new Masters students and six Certificate students, bringing the total number of M.S. degrees completed at the Center to 45 and the total number of Certificates in Ocean Mapping to 54.

## JHC – Originated Courses

### COURSES

Fundamentals of Ocean Mapping  
Ocean Mapping Tools  
Hydrographic Field Course  
Marine Geology and Geophysics  
Acoustics  
Data Structures  
Data Visualization  
Seafloor Characterization  
Geodesy and Positioning for OM  
Special Topics: Law of the Sea  
Special Topics: Bathy-Spatial Analysis  
Special Topics: Ocean. Data Analysis  
Mathematics: For Geospatial Studies  
Time Series Analysis  
Seamanship  
Underwater Acoustics  
Nearshore Processes  
Seminars in Ocean Mapping

### INSTRUCTORS

Armstrong, Dijkstra, Mayer and others  
Dijkstra, Johnson, Monahan, and others  
Dijkstra and Armstrong  
Mayer and Gardner  
Weber  
Ware  
Ware  
Mayer, Calder  
Dijkstra and Wells  
Monahan  
Monahan  
Weber  
Math Department  
Lippmann  
Armstrong, Kelley  
Weber  
Ward  
All

## Modules

Recognizing the need for advanced training for NOAA personnel as well as the need to develop modules for our new “Fundamentals of Ocean Mapping” course. Tom Weber, Andrew Armstrong, Larry Mayer and Semme Dijkstra developed a module to teach the fundamentals of vertical beam echosounding and associated acoustic principles. This module was delivered remotely from the Center (with a Center representative on site) to students in Newport, Oregon in association with the NOAA hydrographic training.

## GEBCO Certificate Program

In 2004, the Center was selected through an international competition (that included most of the leading hydrographic education centers in the world) to host the Nippon Foundation/GEBCO Bathymetric Training Program. UNH was awarded \$1.6 M from the Nippon Foundation to create and host a one-year training program for seven international students (initial funding was for three years). Fifty-seven students from 32 nations applied and in just 4 months



(through the tremendous cooperation of the UNH Graduate School and the Foreign Students Office) seven students were selected, admitted, received visas and began their studies. This first class of seven students graduated (receiving a Certificate in Ocean Mapping) in 2005, the second class of 5 graduated in 2006, the third class of six students graduated in 2007. The Nippon Foundation extended the program for another three years and the fourth class graduated six in 2008, another five graduated in 2009; and six more students graduated in 2010. The Nippon Foundation continued to fund the program beyond 2010 and we graduated another six students in the 2011 academic year and have another six enrolled for academic year of 2012 (see listing below).

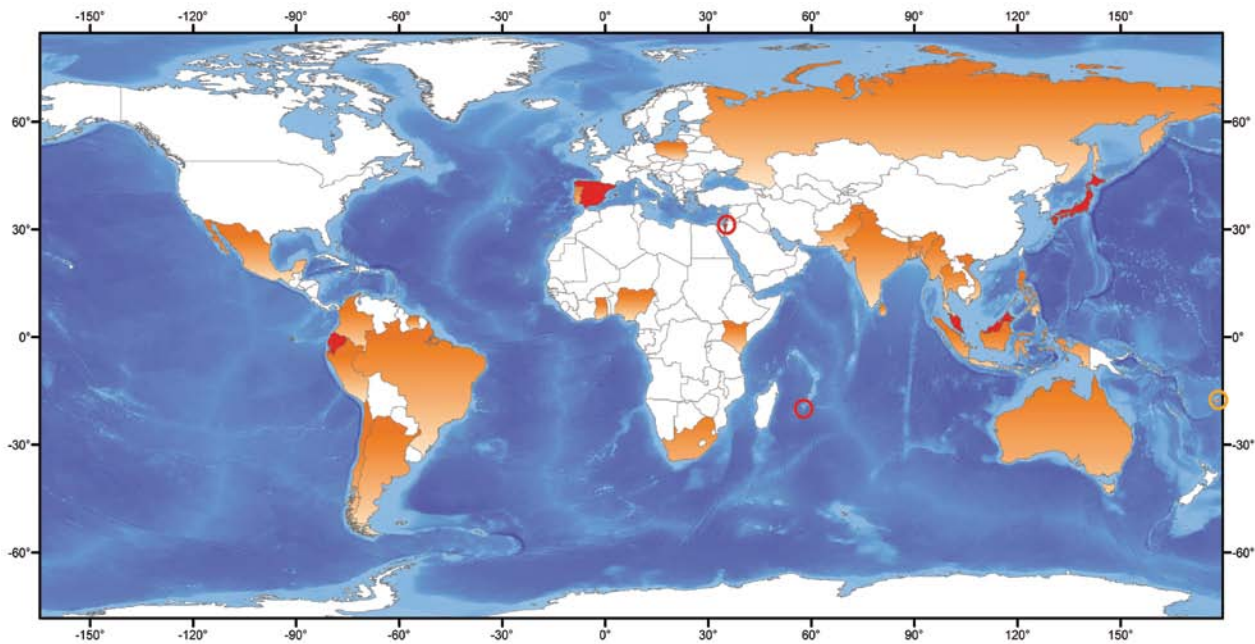

Figure 2-1. Nippon Foundation/GEBCO scholars' home countries. The current 2013-2014 students' countries are highlighted in red.

The Nippon Foundation/GEBCO students have added a tremendous dynamic to the Center both academically and culturally. Funding from the Nippon Foundation allowed us to add Dave Monahan to our faculty in the position of program director for the GEBCO bathymetric training program. Dave brings years of valuable hydrographic, bathymetric and UNCLOS experience to our group and, in the context of the GEBCO training program, has added several new courses to our curriculum. Dave Monahan has supervised three master's students, namely C. Lacerda, A. Abramova and F. Felipe Barrios-Burnett. C. Lacerda unfortunately became ill and a leave of absence was arranged for her.

The networking phase of the 2012-2013 class (i.e., working visits by Nippon Foundation/GEBCO students to other ocean mapping centers and/or participation in hydrographic cruises) included visits by three scholars to NOAA's National Geophysical Data Center (NGDC) and co-located International Hydrographic Organization Data Center for Digital Bathymetry (IHO-DCDB) in Boulder, CO (Figure 2-2), to the School of Earth and Environmental Science of James Cook University (Townsville, Australia), British Oceanographic Data Centre (BODCI in Liverpool, Lamont-Doherty Earth Observatory at Columbia University, Alfred Wegener Institute (Bremerhaven), Integrated Ocean and Coastal Mapping (IOCM) and National Ocean Service (NOS) divisions of National Oceanic and Atmospheric Administration (Silver Spring) and a short survey cruise for bedform parameterization and object detection onboard the R/V *Sharp*.

The 2012-2013 class attended an intense two-day training session at NOAA's National Geophysical Data Center (NGDC) and co-located International Hydrographic Organization Data Center for Digital Bathymetry (IHO-DCDB) in Boulder, CO. Nine Nippon Foundation /GEBCO Scholars attended the GEBCO annual meetings at the Istituto di Scienze Marine in Venice, Italy in October. The scholars participated in all the working groups and sub-committees. Nineteen Nippon Foundation/GEBCO scholars were represented as coauthors during both the presentations and scientific posters display for the Eighth GEBCO Science Day.

**Nippon Foundation / GEBCO Training Program 2012/2013**  
The visit to an international laboratory is included in the training program to round out the students' training, to help them build networks and to deepen some of their newly-acquired theoretical knowledge. This training includes familiarization with the programs the visited organization is engaged in, as well as some directed work under supervision.

**SHARED BENEFITS: Students Lab Visit to  
NATIONAL GEOPHYSICAL DATA CENTER  
MARINE GEOLOGY & GEOPHYSICS DIVISION**

**THE DEVELOPMENT OF A DIGITAL ELEVATION MODEL AROUND PORTSMOUTH, NH**

**Goal of this project:**  
The goal of the project was to build a bathymetric-topographic Digital Elevation Model (DEM) around the area of Portsmouth, NH. A DEM has multidisciplinary applications for ocean engineering and coastal engineering using geographic information systems (GIS) software. The DEM was developed using a number of bathymetric and topographic datasets, allowing us to apply the knowledge gained from the Nippon Foundation/GEBCO training course.

**Work flow of developing DEM:**

- 1. Setting area and Data collection**  
The area around Portsmouth, NH was selected to develop a DEM as this area is surveyed annually during the CCOM Hydrographic Field School. Bathymetric, topographic and bathymetric-topographic datasets covering for this area were collected from the following sources: NOAA's National Ocean Service (NOS), Center for Coastal and Ocean Mapping/Joint Hydrographic Center (CCOM/JHC) and U.S. Geological Survey (USGS). Figure 1 shows the footprint of datasets used to develop DEM. The shoreline data for Portsmouth area (Fig. 2) was extracted from NOAA shoreline database (<http://www.nps.noaa.gov/NSDB/>).
- 2. Datum conversion**  
Datasets used to build Portsmouth DEM were originally referenced to various horizontal and vertical datums. For example, vertical datums of datasets include Mean Lower Low Water (MLLW), Mean Low Water (MLW) and North American Vertical Datum of 1988 (NAVD88). The datum conversion tool "Datum" (<http://datum.noaa.gov/>) was used to establish common datums in developing the DEM. All datasets were transformed to the horizontal datum of NAD83 and vertical datum of NAVD88.

Fig. 1 Footprint of datasets used to develop DEM

Fig. 2 Source and coverage of shoreline data  
<http://www.nps.noaa.gov/NSDB/>

**Htike Htike** htikeh@gmail.com  
River and Coastal Engineering Department, Myanmar Maritime University

**Takafumi Hashimoto** hashimotakafumi@hotmail.co.jp  
Hydrographic and Oceanographic Department, Japan Coast Guard

- 3. Creating base bathymetric surface in GMT**  
Before building the DEM, a base bathymetric surface which has 1/3 arc second grid cell size, was created by using GMT program surface. Bathymetric datasets and shoreline data were used to create this base bathymetric surface. The depth of shoreline was defined as -1.0 m, in order to divide the land and water areas.
- 4. Building the DEM in MB system**  
In this step, a certain gridding weight was assigned to each topographic and bathymetric dataset based on the data quality to determine the data contribution in creating the DEM in MB system (Fig. 3). The tool "mbgrid" with spline tension were used to interpolate values for data gaps.
- 5. Development of Portsmouth DEM**  
Figure 4 shows the created bathymetric-topographic DEM of Portsmouth, NH. The grid size of 1/9 arc second (11.3 m) was selected to produce this final product.

Fig. 3 Concept of assigning gridding weight

Fig. 4 Digital Elevation Model of Portsmouth, NH

**NATIONAL OCEAN SERVICE  
SIDE SCAN SONAR DATA  
INVENTORY DEVELOPMENT**

**Karolina Chorzewska**  
karolina.chorzewska@gmail.com  
Hydrographic Support Squadron of the Polish Navy

**Aim of the project:**  
The aim of the project was to identify the NOS surveys' datasets with towed Side Scan Sonar data collected, generate mosaics as the new product, based on available data and make them easily available within the hydrographic surveys database, in addition to bathymetry data and other oceanographic information.

**Actions:**

1. Surveys within the NOS surveys' database, where Side Scan Sonar data were collected, were identified using their metadata.
2. Surveys with Side Scan mosaics already posted as a products online were identified using online tools.

Fig. 1 Examination of online data for posted TIFF mosaics - H11762 survey as an example.  
(<http://www.ngdc.noaa.gov/ingeg/bathymetry/hydro.html>)

3. Side Scan mosaics, as geo-referenced images, were generated for those surveys, where side scan data were collected and processed. They will be made publicly available as a new product offered by NGDC.

**Results:**

1. The inventory of 312 surveys containing towed Side Scan data was established.
2. 17 surveys were processed using Caris HIPS and SIPS software.
3. 26 georeferenced TIFF mosaics generated as the new products.

Fig. 2 An example of project product. Side Scan Sonar mosaic, with 1m resolution, 200% coverage, generated from H11338 survey data, displayed over the nautical chart No. 12305.

**Acknowledgements:**

- Thanks to Mr. Nezar Mhann and Mr. Warren Seaberg, 2 Hydrographic Technicians, USNA.
- Prof. Mike Neer, former Executive Director, Center for Coastal and Ocean Mapping.
- Development of Digital Elevation Model of Portsmouth, NH, Mr. Barry Rubin and colleagues.
- Nippon Foundation - GEBCO Training Program for the opportunity provided.

Figure 2-2. Poster based on lab visits by Karoline Chorzewska, Htike Htike and Takafumi Hashimoto to NOAA's National Geophysical Data Center (NGDC) and co-located International Hydrographic Organization Data Center for Digital Bathymetry (IHO-DCDB) in Boulder, CO.

The Nippon Foundation continues to provide funds to GEBCO to develop and deliver projects in which the graduates from the first nine years will be trained to take leadership roles. This funding was used to launch a project to produce an international bathymetric compilation map and grid of the Indian Ocean. The aim of this multi-nation project is to assemble all acoustic bathymetric data from the different research cruises and hydrographic surveys undertaken in the Indian Ocean, combine them with satellite altimetry where necessary, and publish a regional bathymetric map and grid that will stand alone and will also be integrated into the next GEBCO world ocean map and grid. GEBCO has contracted JHC/CCOM to host the project and in response, Dr. Rochelle Wigley, a former JHC/CCOM student and GEBCO Scholar, was recruited to direct the project. Twenty-eight GEBCO graduates of the UNH program from fourteen nations bordering on the Indian Ocean were invited to participate and it is expected that other Scholars from adjacent areas will also contribute. Dr. Wigley has now taken over a greater role in the day to day management of the Nippon Foundation/GEBCO training program as Dave Monahan reduces his schedule and takes on the role of Executive Manager.

## GEBCO Students (2013-2014)

STUDENT	INSTITUTION	COUNTRY
Gustavo Crespo	Spanish Navy Hydrographic Office	Spain
Ravi Hemanaden Runghen	Prime Minister's Office of the Republic of Mauritius	Mauritius
Daishi Horiuchi	Japan Coast Guard Hydrographic and Oceanographic Department	Japan
Tomer Ketter	Israel Oceanographic and Limnological Research	Israel
Ramli Mohd	National Hydrographic Centre of the Royal Malaysian Navy	Malaysia
Nilton Sanchez Espinoza	Oceanographic Institute of the Ecuadorian Navy	Ecuador



## Hydrographic Field Course

The 2013 Summer Hydrographic Field Course brought the R/V *Coastal Surveyor*, R/V *Cocheco*, 12 JHC/CCOM students, and technical staff, all under the supervision of Semme Dijkstra, to the waters offshore of Rye, NH. The primary objective was to extend southwards the survey area covered by the hydrographic field course in 2006.



Figure 2-3. Students in the 2013 Summer Hydrographic Field Course working in the field.

One hundred and twenty-three linear nautical miles of data were collected in water depths ranging from 1 to 10 m below MLLW, resulting in a total areal coverage of 1.5 nm<sup>2</sup> (Figure 2-4). Additionally, nine grab samples were obtained, along with seafloor video coverage of each of the sampling sites.

Data were collected and processed using HYPACK, CARIS and QPS software. A comparison with Charts 13274, 13278 and 13282 was performed and the observed depths generally matched the charted depths, but differences were observed in proximity to a number of rocky outcrops. In these areas, shoaler depths were observed resulting in 39 DTONS (affecting eight charts) that have been reported to NOAA.

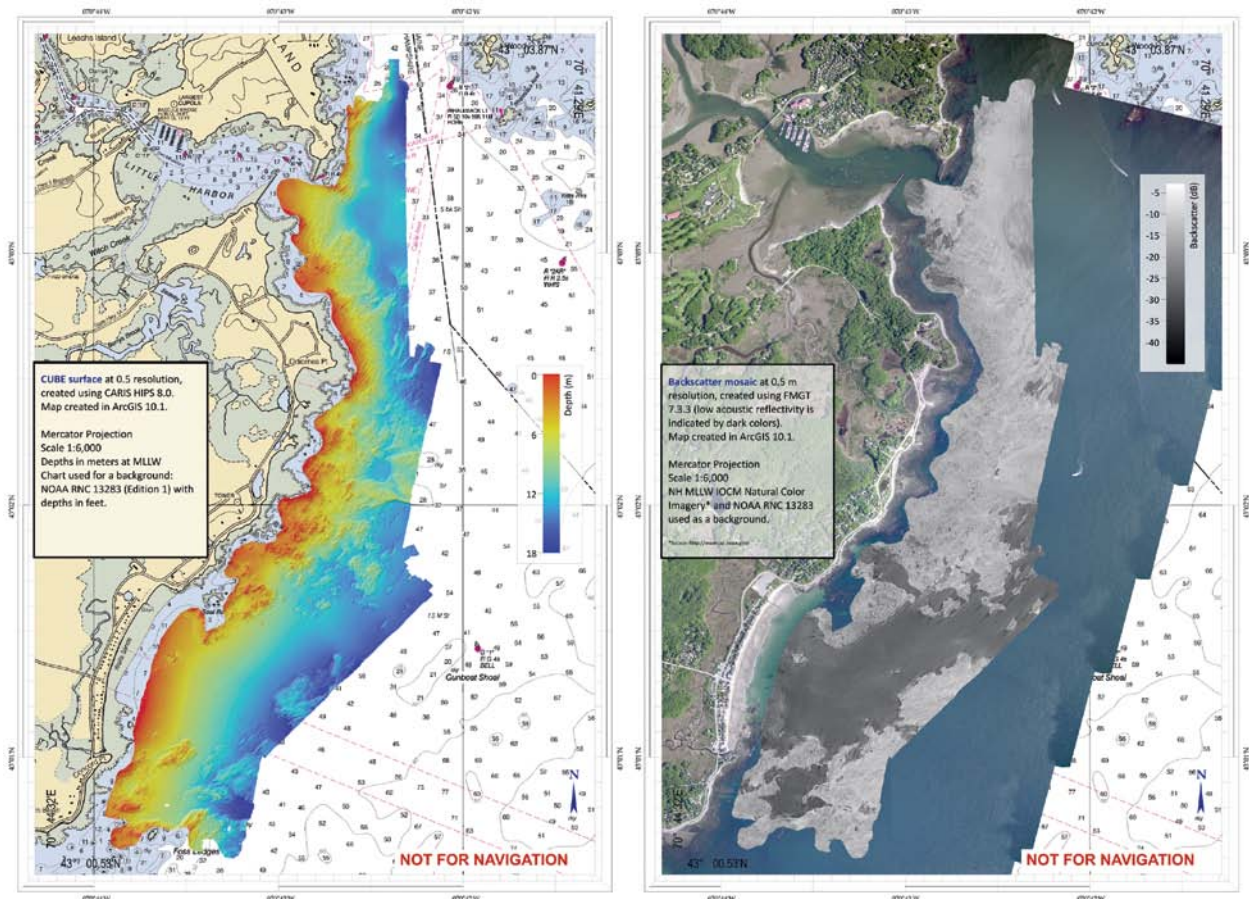

Figure 2-4. Bathymetry and backscatter products of the 2013 Hydrographic Field Course off Rye, NH.



## Extended Training

With our fundamental education programs in place, we are expanding our efforts to design programs that can serve undergraduates, as well as government and industry employees. We have begun a formal summer undergraduate intern program we call SURF (Summer Undergraduate Research Fellowship—see below). Additionally, we have begun hosting Hollings Scholars (see below) and we continue to offer our facilities as a venue for industry and government training courses and meetings (e.g., CARIS, Triton-Elics, SAIC, Geoacoustics, Reson, R2Sonic, IVS, ESRI, GEBCO, HYPACK, Chesapeake Technologies, ATLAS, IBCAO, SAIC, the Seabottom Surveys Panel of the U.S./Japan Cooperative Program in Natural Resources (UJNR), FIG/IHO, NAVO, NOAA, NPS, ECS Workshops, USGS, Deepwater Horizon Sub-surface Monitoring Unit, and others). This has proven very useful because our students can attend these meetings and are thus exposed to a range of state-of-the-art systems and important issues. Particularly important have been visits to the Center by a number of members of NOAA's Coast Survey Development Lab and National Geodetic Service in order to explore research paths of mutual interest and the visits of many NOAA scientists to discuss NOAA priorities for multibeam-sonar systems and surveys as part of a series of NOAA Multibeam Workshops and the developing Intergovernmental Working Group for Integrated Ocean and Coastal Mapping (IWG-IOCM).

## SURF Program and Hollings Scholars

The Summer Undergraduate Research Fellowship (SURF) program was initiated in 2012. The SURF program is designed to create research experiences for undergraduate students who are interested in pursuing graduate work. SURF is aimed primarily at students who are working toward a degree in science, engineering, or math and are completing their junior year. Students accepted into the program spend up to ten intensive weeks (normally early-June to mid-August) working under the guidance of a faculty member. They conduct research related to acoustics, bathymetric mapping, habitat mapping, lidar, marine geology and geophysics, optical imaging, sonar signal processing, or data visualization. Research activities include laboratory experiments, field work, a research cruise, data analysis, model development, or instrument development. The research conducted by the fellows is presented to Center faculty and staff at the end of the summer and summarized in a written report.

### 2013 SURF Fellows and Projects

- Fellow:** Kacper Augustyniak, Poznan University of Technology, Poland
- Advisor:** Brian Calder
- Project:** Hydrographic Data Processing on a Robust, Network-Coupled Parallel Cluster
  
- Fellow:** Matthew Birkebak, University of New Hampshire
- Advisor:** Shachak Pe'eri
- Project:** Spectral Characterization of Digital Cameras
  
- Fellow:** Julien Ogor, ENSTA Bretagne, France
- Advisor:** Brian Calder
- Project:** Robust Surface Construction and Slope Estimation from Hydrographic Data

In 2013, we also hosted two Hollings Scholars, recipients of prestigious fellowships offered by NOAA to talented undergraduates to work with NOAA researchers at an appropriate research facility.

### 2013 Hollings Scholars and Projects

- Scholar:** Mali'o Kodis
- Advisor:** Adam Skarke
- Project:** U.S. Atlantic Margin Methane Plumes Identified from Water Column Backscatter Data Acquired by NOAA Ship *Okeanos Explorer* (Mali'o won the AGU best student poster award for her presentation of her summer internship work.)
  
- Scholar:** Matthew Sharr
- Advisor:** Christopher Parrish
- Project:** Coastal Lidar Vertical Uncertainty Analysis in Hurricane Sandy Impact Region

## Academic Year 2013 Graduate Students

STUDENT	PROGRAM	ADVISOR
Bajor, Eric	M.S. Mech. Eng.	Weber
Borba, Caesar	M.S. E. Sci. Ocean Mapping	Armstrong
Barrios Burnett, Felipe	M.S. E. Sci Ocean Mapping	Monahan
Englert, Christopher	M.S. E. Sci. Ocean Mapping	Mayer
Fandel, Christina	M.S. E. Sci. Ocean Mapping (rec'd 2013)	Lippmann
Flinders, Ashton	M.S. OE Mapping	Mayer
Freire, Ricardo	Ph.D. OE Mapping	Alexander
Guo, Xiao	M.S. OE Mapping	Parrish
Heaton, John	M.S. Mech. Eng.	Weber
Hu, Han	M.S. OE Mapping	Rzhanov
Humberston, Joshua	M.S. E. Sci. Ocean Mapping	Lippmann
Jerram, Kevin	M.S. OE Mapping	Weber
Loranger, Scott	M.S. Oceanography	Lippmann
Manda, Damian (NOAA)	M.S. OE Mapping	Armstrong
McKenna, Lindsay	M.S. E. Sci. Ocean Mapping (rec'd 2013)	Lippmann
Miao, Dandan	M.S. OE Mapping	Calder
Mihtsentu, Mezgeb	Ph.D. Comp. Sci.	Ware
Nifong, Kelly	M.S. E. Sci. Ocean Mapping	Armstrong
Norton, Ashley	Ph.D. NRESS	Dijkstra
Rice, Glen (NOAA)	Ph.D. OE	Armstrong/Calder
Sowers, Derek	Ph.D. NRESS	Mayer
St. Jean, Carmen	M.S. Comp. Sci.	Ware
Welton, Briana (NOAA)	M.S. E. Sci. Ocean Mapping	Armstrong/Weber
Wyllie, Katrina (NOAA)	M.S. E. Sci. Ocean Mapping	Armstrong
Wolfson, Monica	Ph.D. NRESS	Boettcher
Yao, Fang	M.S. E. Sci. Ocean Mapping	Parrish
Yin, Qian	M.S. OE Mapping	Rzhanov

## Status of Research: January–December 2013

When the Center was established in 1999, four primary research directions were identified:

1. Innovative sensor design—understanding capabilities and limitations;
2. New approaches to multibeam and sidescan sonar data processing;
3. New approaches to data visualization, fusion, and presentation;
4. Tools and approaches for seafloor characterization.

Within each of these themes, projects were chosen with long-range research goals designed to make fundamental contributions to the fields of hydrography and ocean and coastal mapping, and with short-term objectives designed to address immediate concerns of the hydrographic community in the United States. Over the years, in response to the needs of NOAA and others, several new research themes were added:

5. Electronic Chart of the Future;
6. Water-column mapping;
7. Capabilities and limitations of lidar for bathymetry, seafloor characterization and shoreline mapping;
8. Coastal process studies—very shallow water mapping;
9. Understanding the capabilities and limitations of AUVs as hydrographic tools;
10. Developing innovative approaches for mapping in support of Law of the Sea.

As our research progressed and evolved, the boundaries between these themes became more blurred. For example, from an initial focus on sonar sensors we expanded our efforts to include lidar and recently, satellite-derived bathymetry. Our data-processing efforts merged into our data-fusion and Chart of the Future efforts. The data-fusion and visualization projects have blended with our seafloor characterization and Chart of the Future efforts as we began to define new sets of “non-traditional” products. This is a natural (and desirable) evolution that slowly changes the nature of the programs and the thrust of our efforts.

With the transition to the new cooperative agreement (2011-2015), the research themes have been re-defined. The request for proposals for the new cooperative agreement prescribed seven thematic headings:

1. Improving the sensors used for hydrographic, ocean and coastal mapping (sonar, lidar, AUVs, etc.) with emphasis on increasing accuracy, resolution, and efficiency, especially in shallow water; (SENSORS)
2. Improving and developing new approaches to hydrographic, ocean and coastal mapping data processing with emphasis on increasing efficiency while understanding, quantifying, and reducing uncertainty; (PROCESSING)
3. Developing tools and approaches for the adaptation of hydrographic, coastal and ocean mapping technologies for the mapping of benthic habitat and exploring the broad potential of mapping features in the water-column; (HABITAT AND WATER COLUMN MAPPING)
4. Developing tools, protocols, non-standard products, and approaches that support the concept of “map once – use many times,” i.e., integrated coastal and ocean mapping; (IOCM)
5. Developing new and innovative approaches for the 3- and 4D visualization of hydrographic and ocean mapping datasets, including better representation of uncertainty, and complex time- and space-varying oceanographic, biological, and geological phenomena; (VISUALIZATION)
6. Developing innovative approaches and concepts for the electronic chart of the future and e-navigation, and; (CHART OF THE FUTURE)
7. Being national leaders in the planning, acquisition, processing, analysis and interpretation of bathymetric data collected in support of a potential submission by the U.S. for an extended continental shelf under Article 76 of the United Nations Convention on the Law of the Sea. (LAW OF THE SEA)

These new thematic headings do not represent a significant departure from our previous research endeavors. However, inasmuch as our efforts since 2011 have been conducted under these new thematic headings, our 2013 research efforts will be described in the context of these seven themes. As with the earlier themes, many of the projects areas overlap several themes. This is particularly true for HABITAT, IOCM, and PROCESSING efforts. In this context, distribution of projects among the themes is sometimes quite “fuzzy.”

As we report on the status of research in 2013, it is important to note that 2013 was a year of severe budget cuts. Between sequestration and hold-backs, the funding available to the Center from the grant was 16% less than the amount originally budgeted for FY2013. With this level of reduction, we have had to reduce efforts on several fronts. In 2013, the reductions were accommodated mostly by non-replacement of personnel (Gardner, Weber, Alexander and Lippmann have gone to half-salaries and we have not filled a faculty line in the field of Habitat Mapping) resulting in reduced efforts on the Habitat Mapping, Law of the Sea, and Chart of the Future research themes.



# Theme 1 – Sensors

## Improving the Sensors Used for Hydrographic, Ocean and Coastal Mapping (Sonar, Lidar, AUVs, etc.) with Emphasis on Increasing Accuracy, Resolution, and Efficiency, Especially in Shallow Water

The Center's work in understanding and improving ocean mapping sensors has steadily grown and encompassed new dimensions. A key component of many of these efforts is our access to, and continued development of state-of-the-art sonar and lidar calibration facilities that allow us to better understand the performance of systems and to develop new approaches to their calibration. Included in our discussion of sensors are our efforts to better understand the behavior of several new sonar systems (both traditional multibeam and phase measuring bathymetric sonars) being offered by our industrial partners, to better understand the performance of lidar and satellite sensing systems for shoreline mapping, bathymetry and seafloor characterization studies, to explore the potential of AUVs as platforms for bathymetric and other measurements, and to make better measurements of the temporal and spatial variability of sound speed in the areas where we are working.

### Sonars

#### Sonar Calibration Facility

##### Developing Approaches to Calibrate MBES in the Field

We continue to make progress in the upgrades to the Center's sonar calibration facility (originally funded in part by NSF), which is now one of the best of its kind in New England. The facility is equipped with a rigid (x, y)-positioning system, computer controlled transducer rotor (with resolution of 0.025 degree) and custom-built data-acquisition system. Measurements that can now be completed include transducer impedance (magnitude and phase) as a function of frequency, beam patterns (transmit and receive), open circuit voltage response (receive sensitivity), and transmit voltage response (transmit sensitivity). In addition, the A/D channel inputs have been optimized as a function of beam angle and the cross-correlation and r.m.s. levels of the transmitted and received channels can be computed in real-time.

In 2013, an automatic positioning mechanism to control the position of calibration spheres in the acoustic tank was designed and tested. This mechanism will make possible the complete the automation of 3-D radiation beam pattern measurements in the acoustic tank using target spheres, minimizing calibration time. The mechanism includes a stepper motor to move the target sphere which is attached to a motor pulley by a braided monofilament line. The line passes through another pulley connected to a rotary encoder which provides feedback position information to PC-based controller. This system has an angular resolution less than  $0.01^\circ$  compatible with the resolution of the Yuasa rotator at the acoustic tank. Figure 3-1 shows the block diagram of this system.

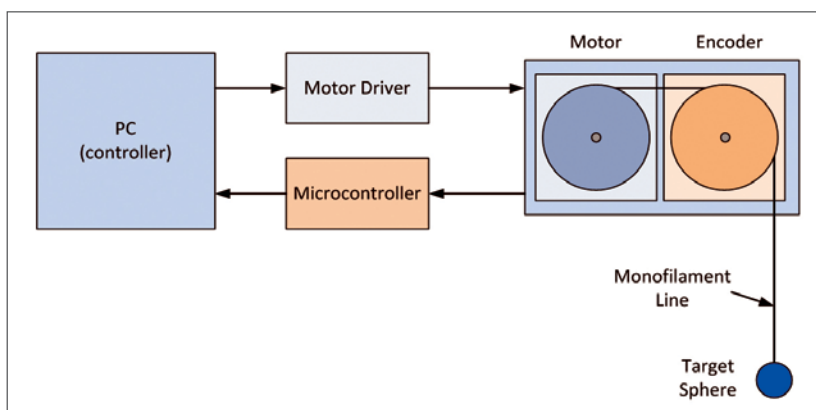

Figure 3-1. Vertical positioning mechanism for target in the acoustic tank.

Carlo Lanzoni (now working as a research engineer), Tom Weber, NOAA Corps officer and student Briana Welton, Glen Rice, and Jonathan Beaudoin were the prime users of the calibration facility in 2013, calibrating systems that will be used on NOAA launches, looking at the capabilities of several new systems, and continuing the work started as part of Lanzoni's M.S. thesis aimed at developing field-calibration procedures for multibeam echosounders (MBES) using a Simrad EK-60 split-beam echosounder and a target calibration sphere. The idea of this approach is that the split-beam

echosounder provides precise information about the target sphere position allowing beam pattern and other calibration measurements to be made on the MBES in the field while it is mounted on the vessel (Figure 3-2). This procedure can reduce the time necessary for a MBES calibration compared to the standard indoor tank methods and allow systems to be calibrated as installed on the vessel on which they are being used.

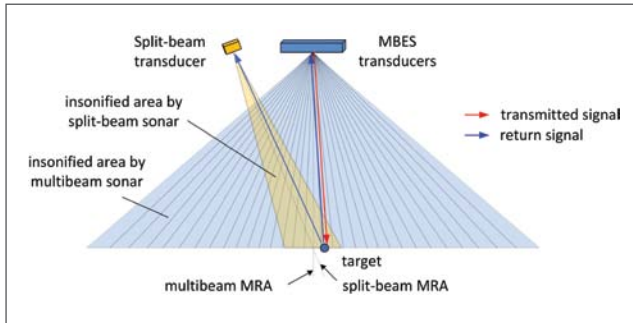

Figure 3-2. Field calibration of multibeam echosounder methodology.

The calibration methodology uses a high-resolution rotation mechanism on the split-beam EK60 system mount to provide coverage of the whole range of beams of the MBES under calibration. The rotation mechanism utilizes a high-resolution stepper motor that allows the positioning of the split-beam transducer with an angular resolution of  $0.1^\circ$ .

Components of the system were tested in the tanks in 2012 and, in 2013, the system was tested in the field using a Reson 7125 multibeam. Unfortunately, electronic issues with the MBES prevented a complete test of the approach (the system had hard drive/firmware problems), however, the general viability of mechanical components were verified (Figure 3-3).

In support of these, and other efforts that take advantage of the split beam capability and standardized

calibration approaches for the EK60 (e.g., the NEWBEX project—see below), we also calibrated our EK60 in the tank this year. Measurements for a high-resolution, three-dimensional combined transmit/receive beam pattern were conducted using a standard target and the two high-resolution rotation mechanisms: the Yuasa rotator (already installed in the acoustic tank) and the recently built rotator (the one used in the multi-beam field calibration methodology project described above). LabVIEW code was designed to incorporate the new rotator with the existing equipment from the tank, providing automated calculation of the radiation beam pattern in just one run and significantly reducing the time required to make beam pattern measurements. The approach also allowed for the assessment of athwartship and alongship angular errors from EK60 data corresponding to the target position.

### Calibration of Reson 7125 MBES from NOAA Launches

In support of the thesis work of NOAA Corps officer and graduate student Briana Welton, two Reson 7125 multibeam echosounders (on loan from the NOAA Ship *Fairweather*) were calibrated in the acoustic tank over the past two years (the calibration of the second one was completed in January 2013). Measurements were performed for combined transmit/receive beam pattern using the standard target method, comparison of source level settings with actual source levels, receive gain calibration and determination of receive gain offset, pulse length/pulse shape of transmitted and received signals, and nonlinearities assessment with the system configured for operating frequencies of 200 kHz and 400 kHz. These calibrations have enabled Welton (working with Jonathan Beaudoin, Tom Weber and Carlo Lanzoni) to develop field procedures along with data reduction and analysis tools for the relative calibration of the Reson 7125 MBES used on NOAA

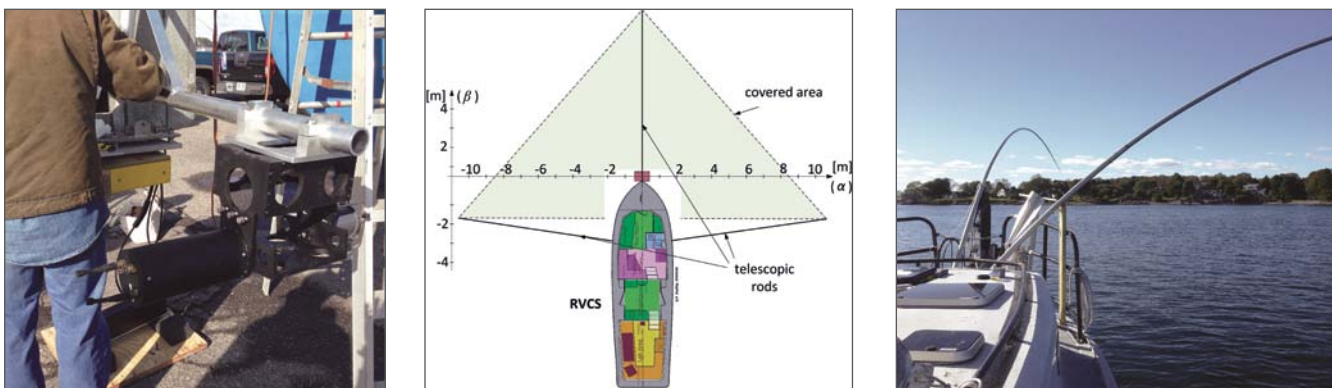

Figure 3-3. EK60 rotation system mounted on R/V *Coastal Surveyor* (left); overall calibration setup (middle) and outriggers for moving target sphere through area insonified by both EK60 and MBES (right).

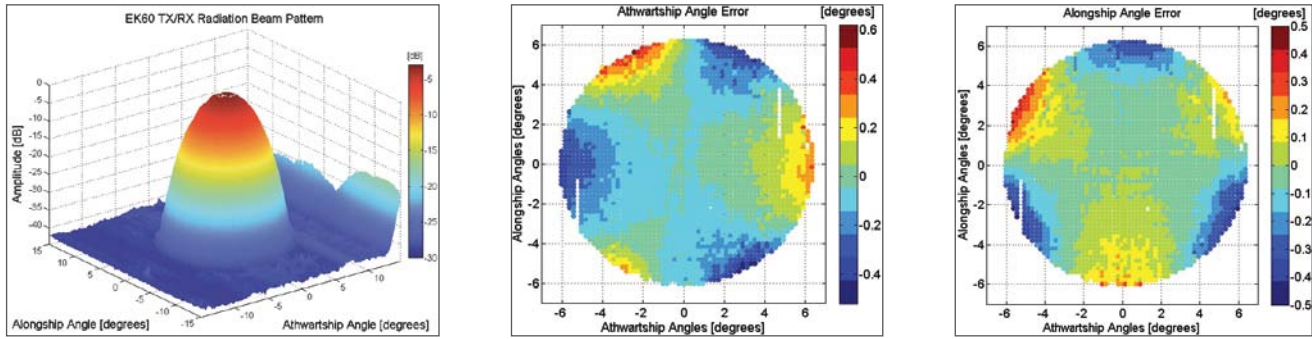

Figure 3-4 shows the results from the beam pattern measurements and the athwartship and alongship angular uncertainties.

launches. The basic idea is to survey standard areas with a calibrated system (i.e., those calibrated in our acoustic test tank) and then bring uncalibrated systems to these areas and develop a relative calibration table (and associated uncertainty values) for all settings that will adjust the non-calibrated system to the calibrated values. Specifically, the field procedure aims to estimate values and/or correctors at least for the following:

1. A calibration constant that allows for conversion of raw digital output into sound pressure level (SPL),
2. Source level calibration curve,
3. Gain level calibration curve.

Additional testing will address the feasibility of establishing other correctors for parameters such as beam patterns and pulse lengths. Preparatory work done to date includes programming of backscatter processing routines that allow for application of the various correctors required in computing seafloor backscatter from Reson 7125 raw seabed imagery data. Follow up work will include establishment of uncertainties associated with the corrector estimates derived from the field calibration. Initial results were presented by Beaudoin on behalf of Welton at the 2013 U.S. Hydrographic Conference. Welton also presented results at the RESON Underwater Technology Seminar in Denmark in September 2013. Output from this work will include development of a standard representation for various system correctors that can then be included in software products such as Geocoder.

The approach is being evaluated using data collected from three NOAA launches operated by the NOAA Ship *Fairweather* in Newport, Oregon during September 2013 (Figures 3-5a and 3-5b). The goal of this work is to improve the consistency of backscatter measurements made from multiple MBES systems in general and to improve the quality and utility of backscatter mosaics created from Reson 7125 systems, in particular, as these are the most common shallow water

system currently being used by NOAA hydrographic field units. The approach is unique in that it determines corrections for most of the terms in the sonar equation pertaining to sonar operation and performance so that they can be applied during processing for any sonar setting combinations, removing the need for setting-specific or survey-specific data or data product manipulation (Figure 3-6).



Figure 3-5a. NOAA launches with identical Reson 7125 MBESs preparing for inter-calibration.

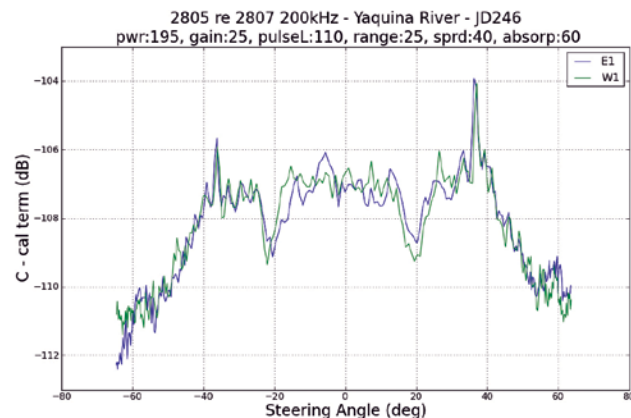

Figure 3-5b. Correction factors (uncalibrated system relative to calibrated system) as a function of beam angle determined for one of the systems for a particular suite of system settings. Green and blue lines represent two crossing of same seafloor (in opposite directions) indicating repeatability of measurements.



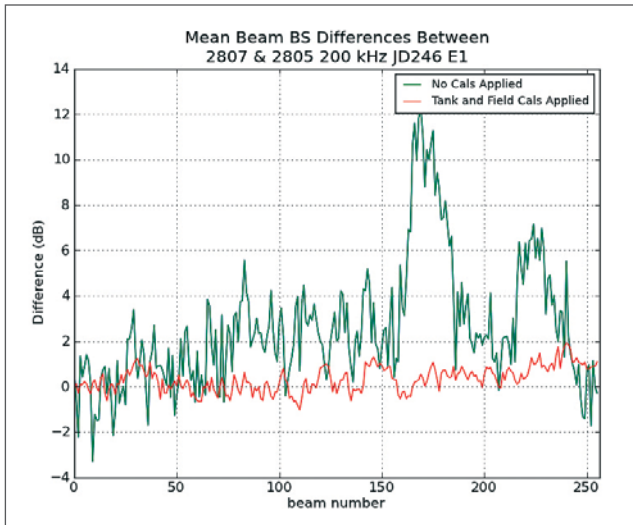

Figure 3-6. Difference between mean beam backscatter data from one coincident line run by two Reson 7125s MBESs when calibration data are not applied to either Reson 7125, and when both the respective tank and field calibration data are applied to the Reson 7125 data from Launches 2805 and 2807. Mean difference between the two systems when tank and field calibrations are applied is 0.32 dB, and 2.58 dB when no calibrations are applied.

### Calibration Site Index Map

As an outgrowth of our activities focused on helping NOAA develop tools for the calibration and assessment of their sonar systems, Paul Johnson has been working with NOAA's Mark Blankenship on developing Site Index maps showing areas suitable for field calibration and system assessment. This index map is meant to provide a one-stop location for operators looking for sites suitable to run either a patch test or to collect data over a reference surface. Mark provided information on sites that the NOAA Ship *Thomas Jefferson* has used off Norfolk and from this a preliminary web map

interface was developed that allows users to view each of the sites and then click on a site to view information about it. Work will continue on this project in the spring of 2014, integrating sites that the Multibeam Advisory Committee (see below) has utilized as well as adding more NOAA sites.

### Calibration of Other Sonar Systems

Along with supporting our own research projects, the Center's acoustic calibration facility is also available to NOAA, our industrial partners, and others for use in quantifying the behavior of new or existing sonar systems. In 2013, a number of systems and sonars were tested or calibrated in our facility or in the field including so as to better understand their performance and capabilities:

1. A Teledyne MB1 multibeam echosounder was tested in the acoustic tank for assessment of radiation beam pattern, power level settings versus actual source levels, pulse length/pulse shape of transmitted signals, receive level versus frequency setting, and the sonar software user interface. Although the tests had to be performed in a compressed time frame, the results were satisfactory for an evaluation of the system. A second Teledyne MB1 multibeam echosounder was tested to provide calibration in support of an experiment by Dale Chayes, Tom Weber and Larry Mayer to evaluate the ability of this sonar to survey under ice.
2. Six deep water single-beam electro-acoustic transducers from Edgetech (models 106Short, DW106, DW216, DW424, KT216A2, and Hullmount106) were calibrated for transmit voltage response (TVR) and impedance in the acoustic tank. A WASSP multibeam echosounder was tested in the acous-

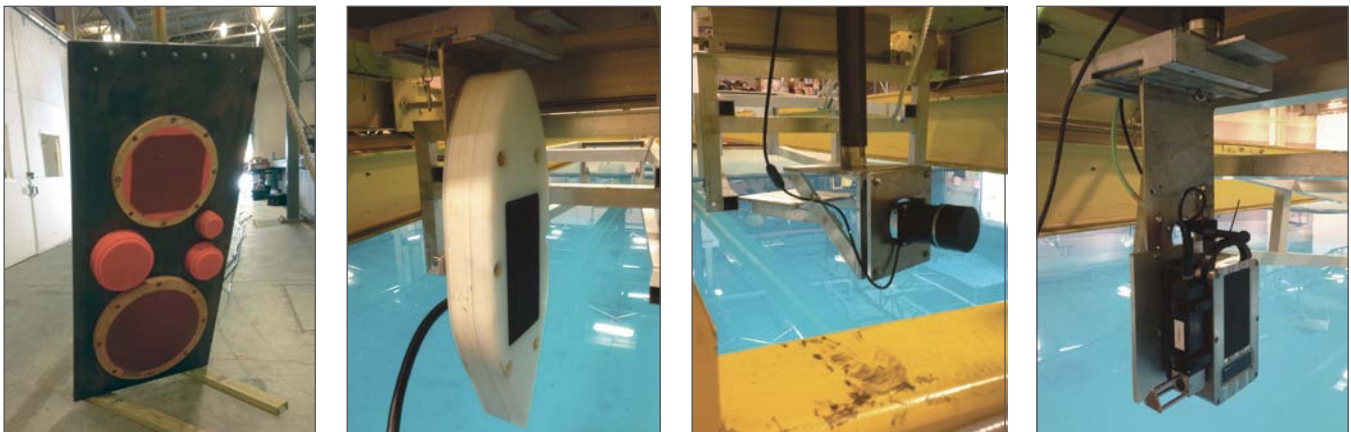

Figure 3-7. Some of the transducers tested in the acoustic tank in 2013. From left: EK60, WASSP, 7125, MB1.

tic tank for evaluation of radiation beam pattern, power level versus actual source level, and pulse length settings.

3. Simrad split-beam transducers (including models ES18/18 kHz and ES38/38 kHz) were tested in the acoustic tank for assessment of radiation beam pattern, source level, and receive level using linear frequency modulation pulses (LFM).
4. Val Schmidt and Christy Fandel worked with Industrial Partner L3/Klein to do field evaluations of the Klein Hydrochart Phase Measuring Bathymetric Sonar; the results of this study will be presented under the DATA PROCESSING theme. Figure 3-7 shows some of the transducers tested in the acoustic tank.

We have also begun a collaborative effort with industrial partner Kongsberg, NOAA fisheries scientists, and scientists at the Woods Hole Oceanographic Institution to look at the capabilities of Kongsberg's new wideband transceiver (WBT), the EK80. Wideband acoustic echosounders offer great promise for characterizing several phenomena, e.g., the seafloor, marine organisms, gas bubbles, as well as very high precision range measurements using pulse compression techniques. A handful of wideband acoustic systems have been previously built, but have not been readily available on the commercial market. This appears likely to change with the introduction of the new Kongsberg EK80 wideband transceiver, which is intended to interface to Kongsberg's fisheries echosounder transducers (one of which JHC is using on the NEWBEX project). In support of this effort, we tested the EK80 in the acoustic tank and, in early December, we had the opportunity to collect broadband acoustic data (160-260 kHz) over the standard NEWBEX line in Portsmouth Harbor.

Prior to running the standard line, we calibrated the WBT with the 200 kHz split-beam echosounder using a 38.1 mm calibration sphere in the Portsmouth Naval Shipyard Boat Basin, a quiet, deep location that is convenient for these type of calibrations. This sphere, which is large compared with the wavelengths used, exhibits several nulls in its theoretical target strength (Figure 3-8), and these nulls are closely matched in the field data indicating that the calibration procedure was appropriate. The difference between

theoretical and empirically observed target strength (TS) curves provides a frequency-dependent calibration that can then be applied to seafloor backscatter data.

After calibration, wideband data was collected on the standard NEWBEX line. A preliminary analysis of wideband seabed scattering strength is shown in Figure 3-9. The initial results suggest that the frequency response (acoustic "color") provide additional information that may be helpful for seabed characterization. For example, rather than strictly using the difference in seabed response at a single frequency to identify that the substrate in locations A and B are different, it may be possible to exploit the frequency response of the seafloor (e.g., the spectral slope) to separate and identify substrate types with higher fidelity. This research is only just getting underway, but suggests a promising avenue for a variety of mapping constituents (e.g., habitat classification, geology).

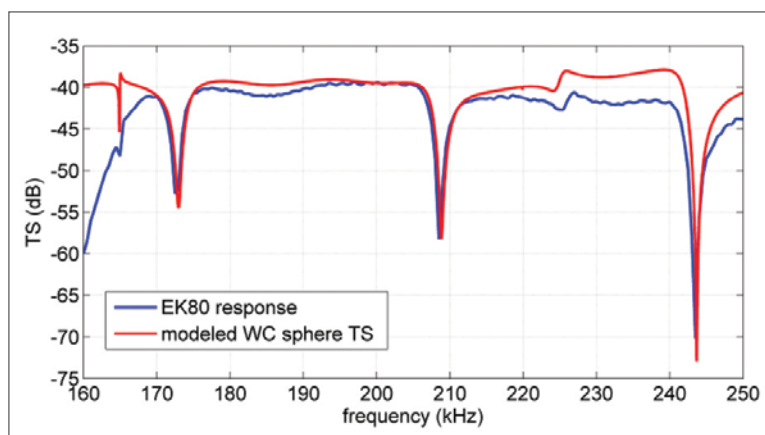

Figure 3-8. Comparison between 38.1 mm WC sphere target strengths: theoretical (red) and measured in the field (blue).

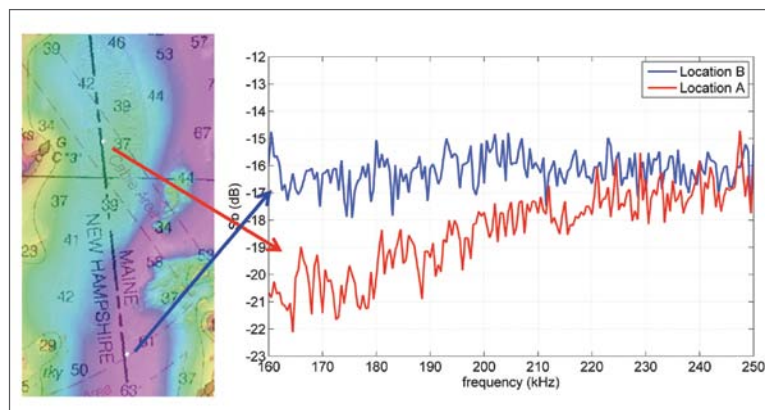

Figure 3-9. Wideband acoustic backscatter collected from two locations along the NEWBEX standard line.

## Very Shallow Water Surveying—CBASS

Tom Lippmann has focused his efforts on mapping bathymetry around shallow harbor entrances and inlets, a region of particular concern to mariners because it is often characterized by rapidly shifting sands, bed-forms, and submerged shallow-water hazards. It is also a region of high scientific interest because sediment fluxes through inlets are often high, playing a role in contaminant transport and in determining the rate of organic carbon transmitted to the continental shelf by rivers. Difficulties working in shallow hazardous waters often preclude accurate measurement of water depth both within the river channel where high flows rapidly change the location of channels, ebb tide shoals, and sand bars, and around rocky shores where submerged outcrops are poorly mapped or uncharted.

To address these issues, Lippmann has developed the CBASS (Coastal Bathymetry Survey System) (Figures 3-10a and 3-10b). In 2012, numerous upgrades were made to the CBASS, including the development of full-waveform capabilities for the 192 kHz singlebeam echosounder on board, the integration and field use of a hull-mounted 1200 kHz RDI Workhorse Acoustic Doppler Current Profiler (ADCP) for observation of the vertical structure of mean currents in shallow water, particularly around inlets and river mouths where the flows are substantial, and, most importantly, the addition of a 240 kHz Imagenex Delta-T multibeam echosounder (MBES) with a state-of-the-art inertial



Figure 3-10a. CBASS in action surveying in New River Inlet, NC.

measurement unit (IMU). RIVET (The Inlet and River Mouth Dynamics Experiment), sponsored by the Office of Naval Research (ONR), tested the system over a four-week period in May 2012 at New River Inlet, NC. During RIVET, bathymetric maps were produced at 10-20 cm resolution from multiple overlapping transects in water depths ranging from 1 to 12 m within the inlet. Ultimately, the noise floor of bathymetric maps obtained with the CBASS (after incorporating CUBE uncertainty analysis) was found to be between 2.5 and 5 cm, with the ability to resolve bedforms with wavelengths greater than 30 cm, typical of large ripples and megaripples.

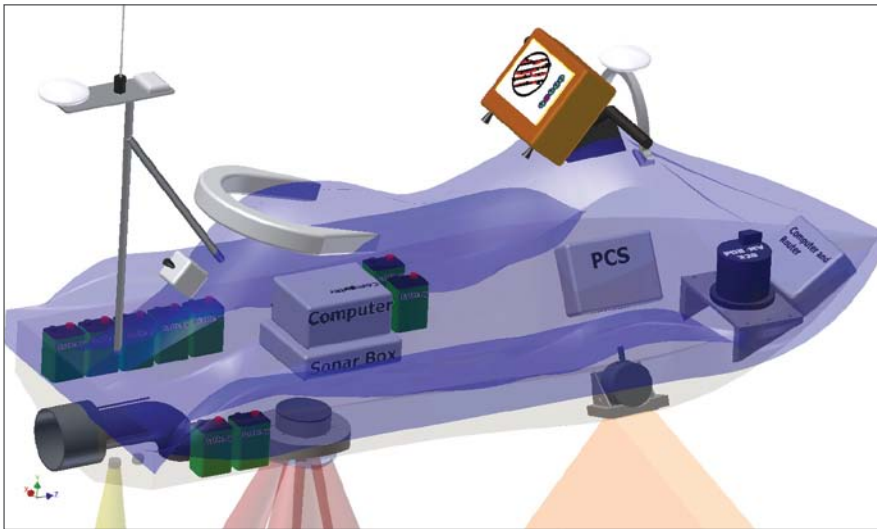

Figure 3-10b. CBASS CAD drawing showing the location of the MBES (peach), SBES (yellow), ADCP (red) with acoustic beam patterns on the CBASS. Also shown are the location of the POS MV IMU and PCS, onboard computers and LAN router, internal battery packs, GPS and RTK antennae, and navigational display monitor.

A leak and subsequent battery fire in the CBASS late in 2012 kept it out of the field for most of 2013. Since then, Jonathan Hunt has been working hard to bring it back to operational status. Improvements being made include waterproof housings for the batteries, hull reinforcements, improved mountings for the sonars, and new display monitors. In the interim, Lippmann focused his shallow water mapping efforts on the use of single beam echosounders in Little Bay and the analysis of these data for seafloor characterization. This work will be discussed under the HABITAT MAPPING theme later in the report.



## Sea Acceptance Trials—Multibeam Advisory Committee

(For information—funded by non-NOAA sources)

The expertise of the researchers at the Center has been sought of late to help ensure that new multibeam sonar systems being installed by the U.S. academic fleet are working properly. In 2010, Jonathan Beaudoin, Val Schmidt, and Jim Gardner participated in acceptance trials of two multibeam systems. Beaudoin participated in the sea acceptance trials (SAT) for the USCGC *Healy*'s new EM122 multibeam sonar, testing achievable swath coverage, accuracy and precision of the system. Beaudoin and Val Schmidt also participated in the SAT for the University of Washington's EM302 on the R/V *Thomas Thompson*. Jim Gardner participated in the sea acceptance trial of the Kongsberg EM122 newly installed on the University of Hawaii's R/V *Kilo Moana*, testing noise levels and swath-width issues. In all cases, Center researchers were able to offer valuable advice on the operational status of the systems.

This role of the Center in evaluating the performance of the academic communities MBES systems was formalized in 2011 with the funding of Jonathan Beaudoin and Paul Johnson (along with Vicky Ferrini at LDEO) to establish a Multibeam Advisory Committee (MAC) with the goal of ensuring that consistently high-quality multibeam data are collected across the U.S. academic research fleet (UNOLS vessels). The strategy is to create a community of stakeholders, including representatives from operating institutions, funding agencies, and key outside experts from the user and technical/engineering communities that can assist in providing guidance on a broad array of multibeam issues. A part of the MAC effort is the development and dissemination of best-practice documentation and quality assurance software as well as collaboration on maintenance agreements and a spare parts pool.

MAC activities to date include ship visits by several of the team members. Acoustic noise profiling tests of R/V *Melville* (by Tim Gates, part of the MAC team) found that the *Melville* is a relatively quiet platform with the anti-roll tank transfer pumps being the only mechanical source of acoustic interference. In March 2012, Beaudoin and Johnson took part in R/V *Kilo Moana*'s transit from Portland, OR to Honolulu, HI to document the EM710 and EM122 installations and to provide preliminary assessments of the sensors' performances. Additional activities included installation of, and training for, Beaudoin's SVP Editor software (see the DATA PROCESSING section below), as well as the establishment of an automated data backup system.

As part of the MAC initiative and the general collaboration between the Center and IFREMER, an experimental implementation of a real-time multibeam performance prediction model that uses sonar run-time parameters (e.g., source level, beam patterns, pulse widths), and environmental data to drive a sonar equation-based range performance prediction model has been developed (Figure 3-11). The performance prediction model that deals with frequency encoded multi-sector MBES has been developed and used by Xavier Lurton on many occasions. Beaudoin implemented it as a real-time tool with some minor augmentations such as accounting for refraction effects during the maximum range estimation process, using position information to lookup oceanographic temperature/salinity properties to better estimate attenuation effects, and computing attenuation effects over the refracted ray path.

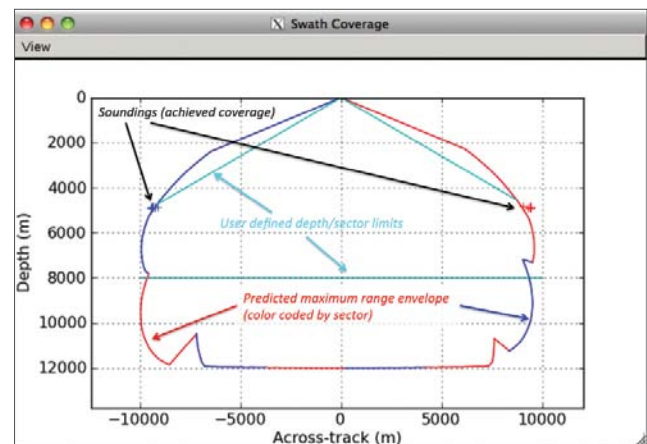

Figure 3-11. Example of real-time coverage performance prediction tool showing expected coverage from a Kongsberg Maritime EM122 12 kHz multibeam echosounder running in DEEP mode.

The tool enables MBES operators to quickly determine whether their system is underperforming by comparing the achieved coverage to that predicted by a continually updated performance prediction model. This is particularly useful during sea acceptance trials (SATs) to help explain discrepancies between expected and achievable coverage that can result from unrealistic expectations that are often informed by experience with other systems in other environmental conditions. This tool can also be used during SATs to predict coverage performance as a function of depth when it cannot be explicitly tested during trials due to lack of suitable candidate sites or logistical reasons. Another potential

application is to use the discrepancy between predicted and achieved coverage as an indicator of overall system performance over its lifetime to monitor for things like transducer degradation over time or sudden changes in self-noise level associated with changes in the vessel's machinery operations.

The tool's real-time predictions depend heavily on being able to determine many of the sonar equation parameters from a real-time data feed provided by the sonar. Still at the proof-of-concept stage, this first implementation is designed to work with Kongsberg Maritime (KM) MBES though it can easily be extended for use with systems from other manufacturers that provide real-time network data subscription services. Remaining work includes verification of the implementation of the IFREMER model and improvements to the user interface. This will also allow operators to determine optimum depth to switch modes for a given system and optimum choice of systems when multiple systems are available.

During the *Kilo Moana* cruise, the MAC established the conventions to be used for documenting system status, acquisition parameters, and operational protocols for a properly functioning multibeam. As the MAC develops a database of best operating practices, documentation of system setups, and learns new ways of handling data this will be a benefit to all operators of multibeam systems since this knowledge will be shared through the MAC's website (<http://mac.unols.org/>).

In 2013, as part of the MAC effort, Johnson and Beaudoin conducted a shipboard visit to assess the *R/V Roger Revelle's* EM122 systems. This assessment was conducted during a transit from San Diego, CA to Anacortes, WA. During the ship visit, the UNH team ran the full suite of MAC multibeam system assessments including, system geometry verification, a patch test, system performance evaluations, and worked on the generation of "cookbooks" to aid users with the operation of the system.

As part of the software upgrades, Paul generated a new virtual machine (VM) that can be distributed to users of other multibeam systems looking for tools to evaluate their systems. This VM is based on an Ubuntu virtual machine with several open source software packages loaded onto it (Generic Mapping Tools, MB-System, and GDAL) to provide interaction with various types of data. A series of multibeam system performance testing scripts have also been ported to work in this environment. These scripts will take user-specified raw files and generate a grid (Figure 3-12, left), will remove all topography that exceeds certain slope criteria (to assure that a flat seafloor is being evaluated) and then use cross-line survey files to calculate performance curves (Figure 3-12, right) including one for Depth Standard Deviation (% Water Depth) vs. Angle and one for Depth Bias (% Water Depth) vs. Angle. To run these scripts, users simply copy their raw multibeam files into a defined directory structure and the script will then take care of the rest.

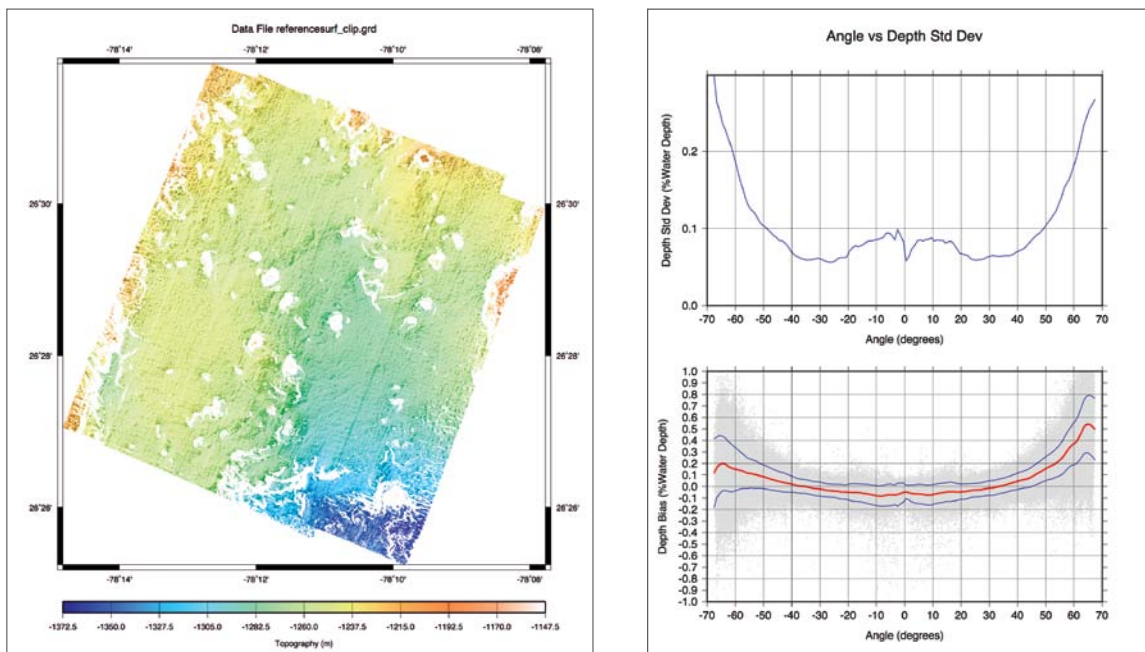

Figure 3-12. Automatic cross-check tool. Grid generated from selected files with sloping surfaces removed (left) and Depth Std. Deviation (% water depth) vs. beam angle and Depth Bias (% water depth) vs. beam angle (right).

These scripts are designed for users who wish to assess their multibeam systems, but have little experience or knowledge of working with programs in a Linux environment. The VM will work on both Windows and Macintosh platforms and, as an added benefit, users of the VM have access to fully compiled and ready-to-use versions of MB-system, GMT, and GDAL for their own work.

Throughout the year, Beaudoin and Johnson were also busy with the MAC's helpdesk, a web application designed for tracking issues and questions that operators of multibeam systems of the U.S. academic fleet submit through email. Questions concerning SIS stability, proper setup of acquisition parameters, requests for identifying issues with data, and many more come in frequently. Amongst the queries was a request from the R/V *Langseth* to aid with a patch test since they needed to calibrate their EM122 system prior to a fall mapping cruise. To aid in this effort, Beaudoin developed a program to strip out all but the essential information that is necessary from a raw Kongsberg file to work up static offset values. Beaudoin and Johnson then independently processed the data transmitted from the *Langseth* from a patch test site designed by Beaudoin, determined new static offset values, verified that each processing method yielded the same results, and then transmitted the values back to the *Langseth* for entry into SIS. The *Langseth* reported that this worked very well for them and this method could provide a roadmap to future remote patch test support for other vessels.

Institutions outside of the UNOLS fleet have also come to us for assistance with their MBES systems. The Center, in collaboration with colleagues from IFREMER in France, assisted the Schmidt Ocean Institute (SOI) with the harbor and sea acceptance trials of all acoustic systems on their newly refitted vessel *Falkor* and has entered an agreement with SOI for long-term assistance in maintaining technician skill sets, monitoring acoustic system health, etc. In March 2013, Johnson, Beaudoin and Center graduate student Ashton Flinders sailed aboard the R/V *Falkor* to inspect the EM302 and EM710 installation, setup and calibrate each system, and assess their performance as compared to the data collected during the sea acceptance trials the previous year. SOI has asked to have this multibeam checkup service performed yearly in order to monitor each system for change and to also make sure each system is collecting the highest quality data possible. Opportunities like this also allow Johnson and Beaudoin to further develop the protocols, tools, and techniques for full assessments of a ship's multibeam echosounder. On the *Falkor* cruise, for example, tools for BIST evaluation,

impedance monitoring, and noise monitoring, were developed along with general improvements on scripts handling the plotting of the data.

The Center has also been contracted by Dr. Robert Ballard's Ocean Exploration Trust to provide similar multibeam sonar installation guidance and long-term support for their vessel of exploration *Nautilus*. In August 2013, Johnson and Beaudoin sailed with a team from IFREMER and the Ocean Exploration Trust aboard the E/V *Nautilus* to conduct sea acceptance trials on a newly installed EM302 multibeam echosounder and a Knudsen 3260 Sub-Bottom Profiler. Johnson worked with the team as they conducted the multibeam acceptance tests including validating the system's installation geometry, performing a patch test in order to determine static offset values, evaluating overall system performance and calibrating backscatter.

## Collaborative Support of NOAA Sonar Systems

Several opportunities arose in 2013 for the Center staff to assist NOAA in troubleshooting various MBES systems aboard three different vessels. NOAA Ship *Rainier* is equipped with a Kongsberg Maritime EM710 whose data quality has been suboptimal since installation due to what would eventually be diagnosed as a software flaw in the Kongsberg Maritime Sound Velocity Correction (SVC) module that prevented the correct application of Applanix TrueHeave. Beaudoin and Rice, along with Burns Foster and Karen Hart from Caris, visited *Rainier* in May of 2013 to re-configure (and recalibrate) the system in a manner that worked around the software flaw. Workflow testing was done to verify that the new hardware and software configurations would continue to provide high quality data using the traditional workflows employed by the vessel. A detailed report was generated and provided to the ship and other NOAA staff (Appendix F).

The Kongsberg Maritime EM122 system aboard NOAA Ship *Ron Brown* was found to have systematic data artifacts after a 2012 ECS survey off the east coast. Jim Gardner identified an asymmetric, refraction-like artifact during post-processing analysis. This was corroborated by Beaudoin in follow up analysis with results being provided to the manufacturer. Initial results indicated that all ancillary sensors were operating as expected and that the curl-like artifact was likely associated with the MBES hardware or electronics. The manufacturer sent a technician to join the vessel, during which the problem has reportedly been resolved after swapping out some of the processing boards in the system's TRU.



During a ship visit to NOAA Ship *Thomas Jefferson*, Beaudoin had the opportunity to assist with a problematic Reson 7125 system that was exhibiting significant bottom mistracking artifacts. With remote guidance from Rice, Beaudoin was able to reconfigure the Reson system to acquire element level data for troubleshooting and to program a basic reader that allowed for quick visualization of the data in post-processing. Up until this troubleshooting stage, ship personnel felt that the system was suffering from an intermittent hardware failure due to potential damage to transducers. Between Beaudoin and Rice examining the element level data, it was quickly determined that the transducers were fine and that the problem appeared to be electrical in nature. The topside electronics were swapped out and the problem was rectified. This quick troubleshooting saved the time associated with removing the wet end and shipping it back to the manufacturer for what would have turned out to be a fruitless investigation.

Additionally, Beaudoin has participated with Glen Rice in NOAA's Sonar Acceptance Project. The echosounders used by NOAA have developed considerably over the past few decades, and OCS continues to adapt to the changing technology, capability, and data volume as new systems are acquired. But as new systems join the fleet, OCS also needs to assess if these new echosounders meet the manufacturer's specification and the needs and requirements of OCS. Historically, OCS has only completed simple tests to make sure the echosounder is operating properly. The purpose of this HSTP project is to update and improve the tests that are performed on new echosounders, to ensure that OCS is buying the right systems and that they are operating properly when purchased. An additional anticipated benefit is to have a baseline against which deterioration or changes in system performance can be compared.

## Lidar

We have long recognized that one of the greatest challenges presented to the hydrographic community is the need to map very shallow coastal regions where multibeam echosounding systems become less efficient. Airborne bathymetric lidar systems make it possible to rapidly collect bathymetric (and other) data in these very shallow regions, but there remains great uncertainty about the accuracy and resolution of these systems. Additionally, lidar (both bathymetric and terrestrial) offer the opportunity to extract other critical information about the coastal zone, including seafloor characterization and shoreline mapping data. We have thus invested heavily in lidar-based research, led by Shachak Pe'eri and Chris Parrish, and will report on this research under the HABITAT theme later in the report.

## Sound-Speed Sensors

One of the fundamental requirements for making accurate bathymetric measurements is a detailed understanding of the spatial and temporal distribution of sound speed. Our inability to capture the spatial and temporal distribution of sound speed at high enough resolution is ultimately one of the largest contributors to uncertainty in our bathymetric measurements. Thus, the Center has given much effort to exploring new and better ways to make sound-speed measurements, and ways to predict the variability in the sound speed field when no measurements, or not enough measurements, are available (see PROCESSING theme).

## CastTime

One of the most exciting recent developments addressing the question of the spatial and temporal variability of the sound speed structure of the water column is the ability to rapidly collect closely spaced sound speed profiles through the use of automated underway profiling systems. One of the key questions facing those using these systems is the profiling interval needed for capturing the true variability of the water column. Too few profiles can lead to poor data quality and too many can lead to degradation and possibly loss of the instrument. This problem was originally addressed by the directed study of NOAA physical scientist Matt Wilson under the supervision of Jonathan Beaudoin (see 2012 progress report). The product of this effort was a software product called CastTime that is able to determine the optimal spacing of sound speed profiles needed to maintain a given level of hydrographic accuracy. Beaudoin and Wilson (who has now returned to NOAA) also collaborated with the manufacturer of Moving Vessel Profiler (MVP) system to implement algorithms that monitor refraction-based sounding uncertainties and provide automated feedback mechanisms that allow for the adjustment of the sampling interval of the underway profiling system. The algorithms first proposed by Beaudoin in 2008/09 have been implemented by Wilson in a standalone software application that communicates with the Rolls Royce MVP controller software to assess the MVP measurements and to prescribe a sampling interval based on the cast-by-cast comparison assessment. The algorithm uses the measurements of the MVP system itself to provide guidance on whether or not to increase or decrease the sampling interval in reaction to the oceanographic conditions observed by the MVP system. The aim of the algorithm is to strike a balance between these two scenarios and to guide the user of the MVP system to collect a sufficient number of sound speed casts such that a desired sounding accuracy is maintained while minimizing wear on system

components and reducing risk of fouling or loss of the towfish. The protocols established in this work provide Center researchers, and other MVP users, the ability to rapidly develop, test and deploy algorithms to enhance the functionality of MVP systems, allowing for streamlined deployment of research ideas into the field.

Originally, Wilson's software was successfully tested in the field by Wilson and Beaudoin with an MVP100 system on NOAA Ship *Ferdinand R. Hassler* in September 2012. Since Wilson's graduation from UNH and subsequent return to NOAA AHB, he and Beaudoin have worked with NOAA HSTP to develop a testing and implementation plan to add CastTime as an operational tool in the NOAA hydrographic survey fleet. The NOAA Ships *Thomas Jefferson* (MVP100) and *Rainier* (MVP200) both offered their platforms as test beds for CastTime in the 2013 field season. Prior to testing, it was decided to disable the feedback loop until the manufacturer had more time to further test the stability of the remote control protocols. Further refinements included adding a pass-through functionality to enable CastTime to share the network delivered MVP data stream to other applications such as Beaudoin's SVP Editor.

Beaudoin and Wilson joined *Thomas Jefferson* in Long Island Sound in March of 2013 to install and test CastTime, and to train survey personnel on its use. Wilson later joined *Rainier* dockside to install CastTime along with Beaudoin's SVP Editor software (see below) and provide training. Unfortunately, *Rainier's* sailing dates were delayed and the software could not be tested while underway. Beaudoin later joined *Rainier* and had an opportunity to improve the communications protocols between CastTime and SVP Editor to allow the full CTD profile information data stream to be passed through to the MBES acquisition system such that it could be used to enable improved seabed imagery radiometric corrections. Initial impressions from the ships are that CastTime works well in the areas that *Thomas Jefferson* operates, i.e., on the east coast where seafloor depths (and thus casting depth) are similar in a given work area, but the algorithm logic needs further refinement to adequately treat the wide range of depths encountered on a cast-by-cast basis during nearshore work done by *Rainier* in Alaska.

Wilson and Beaudoin's work was presented at the 2013 U.S. Hydrographic Conference where it was well received. Colleagues from the US Naval Oceanographic Office (NavO) expressed interest in CastTime and efforts are currently under way to provide source code, installation files and documentation to NavO for testing and potential use in their 2013 field season.

## AUV Activities

In 2006, the Center began an effort to explore the applicability of using a small Autonomous Underwater Vehicle (AUV) to collect critical bathymetric and other data. We teamed with Art Trembanis of the University of Delaware to obtain use of his Fetch3 vehicle. We purchased, calibrated, and integrated a small multibeam sonar (Imagenix Delta-T) into this AUV and, throughout 2007, began to explore its applicability for collecting both hydrographic-quality bathymetric data and seafloor-characterization data. Unfortunately, the Fetch 3 vehicle suffered a catastrophic failure during a mission in the Black Sea. Fortunately, the system was fully insured and we were able to replace the Fetch and Delta-T with a Gavia AUV with a 500-kHz GeoAcoustics GeoSwath phase-measuring bathymetric sidescan and a Kearfott inertial navigation system. Additional capabilities include sensors for temperature, sound-speed, salinity (derived), dissolved oxygen, chlorophyll and turbidity, a downward-looking camera, and a Marine Sonics 900 kHz/1800 kHz sidescan sonar. The new system is a much more mature AUV than was the Fetch, with imagery, bathymetry, and, particularly, positioning capabilities far beyond the original vehicle. We have also purchased a WHOI acoustic modem for the new vehicle that allows enhanced positioning and two-way communication.

Val Schmidt is providing support to both the Center and the University of Delaware AUV operations. He has established a series of standard procedures and checklists for AUV operations and has written a considerable amount of software to monitor and support the Gavia, including code to explore an alternative, and hopefully improved and more deterministic, pipeline for processing phase-measuring bathymetric sonar data.

In 2013, Schmidt continued to refine our efforts to produce hydrographic-quality surveys from autonomous underwater vehicles and, in particular, to look more closely at the pressure sensor and its effect on the resulting depth measurements. In the past, we have identified that surface waves can influence the vehicle's estimate of its own depth, and hence the depth of the total water column, producing artifacts in seafloor surveys from AUVs. We have since successfully removed these artifacts by careful blending of depth estimates from both the pressure sensor and the inertial navigation system. More recently, we have begun to consider other adverse influences on the pressure sensor-derived depth estimates and in particular, the influence on the pressure sensor from local changes in barometric pressure. This has never been quantified with respect to the effect on hydrographic surveys from AUVs,

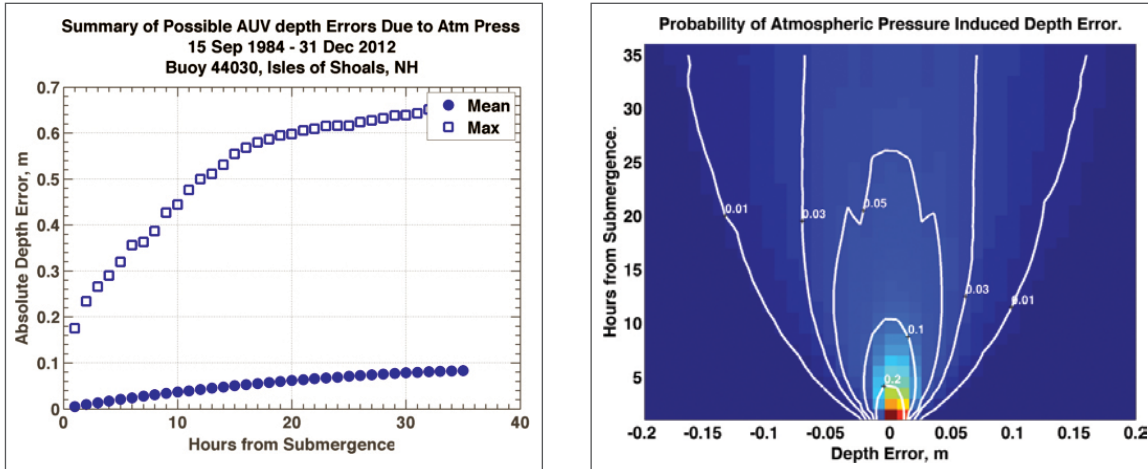

Figure 3-13. (left) The maximum and mean depth uncertainty that might result as a function of time after AUV submergence based on 28 years of hourly pressure data from the Isles of Shoals, NH. Contours of the probability that a depth uncertainty of a given size will occur X hours after submergence (right).

given the nominal duration and horizontal extent of their operations. In an effort to do so, a desktop study was undertaken to look at variations in atmospheric pressure and their potential impact to surveys over 36 hours after submergence under the assumption that no post-processing correction was undertaken.

A 28-year pressure record was used as an input and, over this period, the average depth error that might be induced over a 36 hour period is nearly 0.1 m (Figure 3-14) while over some 36-hour intervals, the depth error could have been as high as 0.65 m. The events that cause these large errors are infrequent, but they can occur. In an attempt to quantify the chances of an error of any given size occurring, the data were used to generate the probability of an error as a function of its size and duration after submergence. Figure 3-13 illustrates, for example, that there is a probability of 0.05 (or 1 in 20 chance) of a 5 cm depth error occurring due to changes in atmospheric pressure during a 10-hour mission.

We continue to take advantage of the ONR-funded "Bedforms Project" where numerous repeat deployments of the Gavia AUV have allowed us to explore the hydrographic and positional accuracy of AUV-collected data. The ONR project is an effort to study the evolution of bedforms and methods of change detection in a littoral environment. The focus of the work is the Redbird Reef site off Delaware where hundreds of subway cars and other manmade objects were submerged to form an artificial reef. Six bathymetric surveys using the Geoswath Phase Measuring Bathymetric Sonar (PMBS) and a singlebeam echosounder on the AUV and a surface-ship mounted Reson 7125 MBES were completed over the site (three in 2012, and three in 2013), including a survey just three days before and a survey seven days after Super Storm Sandy (Figure 3-14).

Navy objectives are to quantitatively characterize changes in seafloor bedforms, but the combination of both surface ship and AUV navigated surveys also affords us an opportunity to compare survey quality

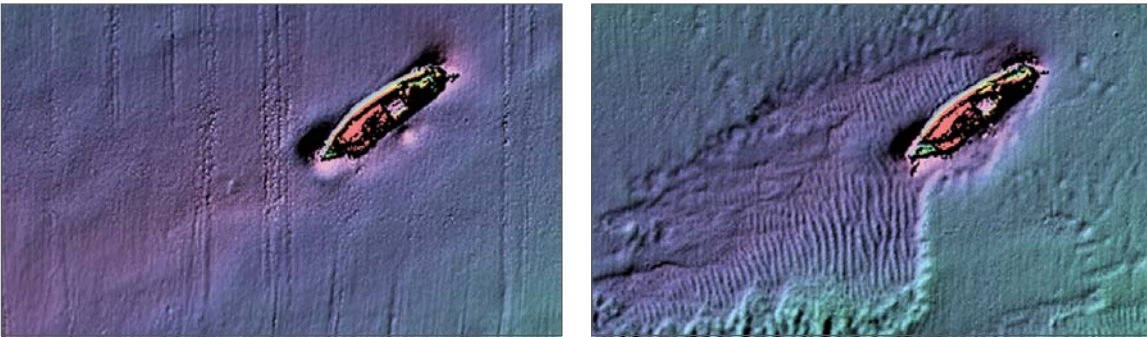

Figure 3-14. Before and after images of impact of Superstorm Sandy on submerged object at Redbird Reef site.



and to consider alternative methods for the processing of AUV collected data. Figure 3-15 shows data from the R/V *Sharp's* RESON 7125, the AUV's Geoswath, and the difference between the two. The *Sharp* data were navigated by a POS/MV with PPP post-processing and ellipsoidal referencing. The AUV data was navigated with a WAAS capable receiver and Kearfott T-24 inertial navigation system and tidal zoning. The bulk of the difference between the surfaces results from navigation errors. The rms difference between the surfaces is 0.17 m, giving an upper bound to the vertical uncertainty of the AUV echosounder relative to that of the ship's. In 27 m of water, the IHO Special Order 2-sigma depth uncertainty requirement is 0.32 m, indicating that the AUV survey may meet Special Order requirements if positioning and processing are carefully done.

Navy objectives are to quantitatively characterize changes in seafloor bedforms, but the combination of both surface ship and AUV navigated surveys also affords us an opportunity to compare survey quality and to consider alternative methods for the processing of AUV collected data. Figure 3-15 shows data from the R/V *Sharp's* RESON 7125, the AUV's Geoswath, and the difference between the two. The *Sharp* data were navigated by a POS/MV with PPP post-processing and ellipsoidal referencing. The AUV data was navigated with a WAAS capable receiver and Kearfott T-24 inertial navigation system and tidal zoning. The bulk of the difference between the surfaces results from navigation errors. The rms difference between the surfaces is 0.17 m, giving an upper bound to the vertical uncertainty of the AUV echosounder relative to that of the ship's. In 27 m of water, the IHO Special Order 2-sigma depth uncertainty requirement is 0.32 m, indicating that the AUV survey may meet Special Order requirements if positioning and processing are carefully done.

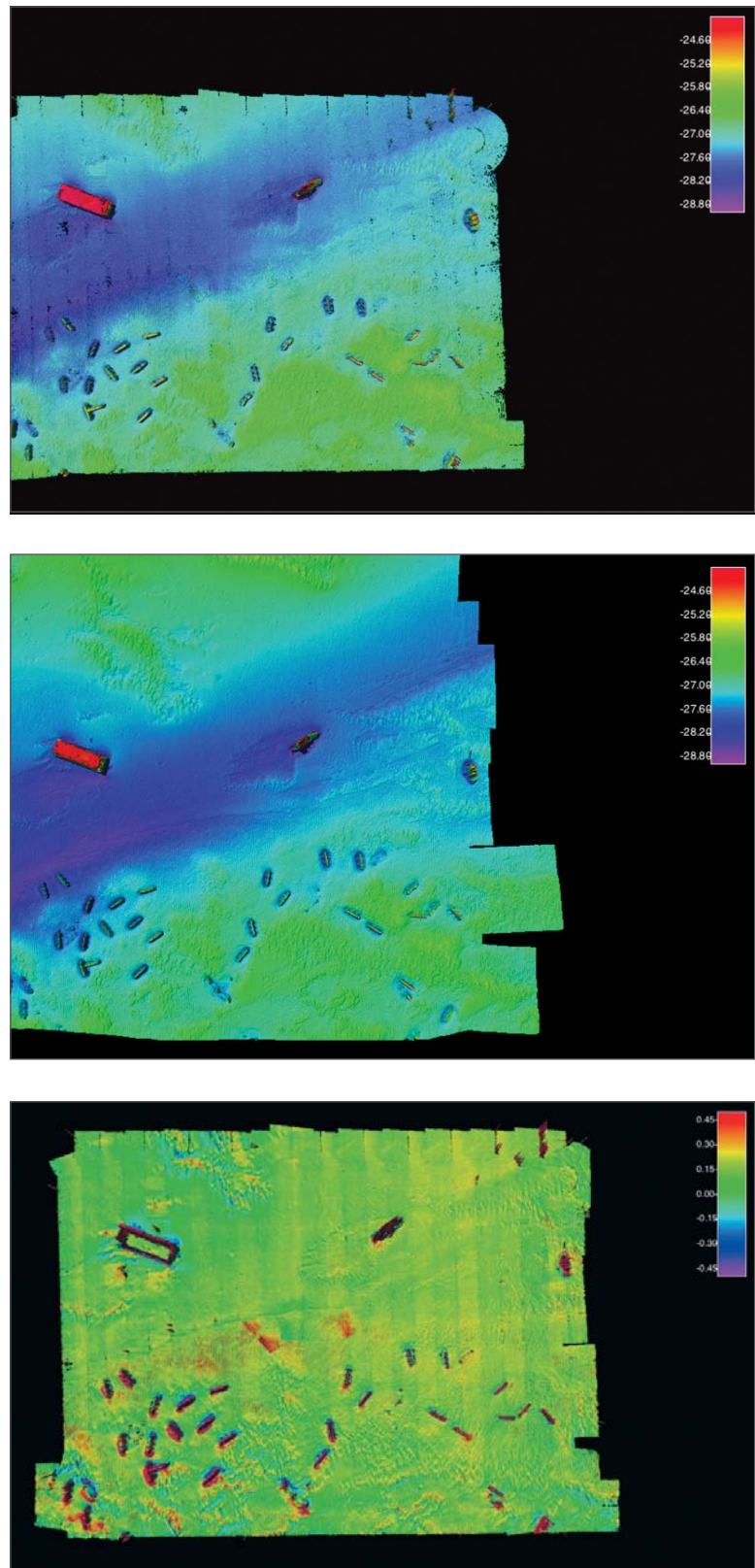

Figure 3-15. Bathymetry from Reson 7125 surface ship-navigated survey (*top*), Geoacoustics Geoswath AUV navigated survey (*middle*), and the difference between the two (*bottom*). The rms difference is 0.17 m.

## Theme 2 – Processing

### Improving and Developing New Approaches to Hydrographic, Ocean and Coastal Mapping Data Processing with Emphasis on Increasing Efficiency While Understanding, Quantifying, and Reducing Uncertainty

Developing better and more efficient means to process hydrographic data has been a long-term goal of Center activities. As the number and type of sensors that we are involved with increases, and the scope of ocean mapping expands, so does the range of processing challenges facing us. In this section we begin with our “bread and butter”—a discussion of bathymetric processing tools that we have developed and are developing for both traditional multibeam echosounders and phase measuring bathymetric sonars. We then explore processing approaches for minimizing uncertainty associated with the temporal and spatial variability of sound speed in the water column, typically the major source of uncertainty in a modern hydrographic survey, and then look at processing tools being developed to extract bathymetric, shoreline and other data from satellite and other imagery. In parallel with our work on bathymetric data processing, we are investigating approaches to understanding the uncertainty associated with the backscatter provided by swath mapping systems and applying this understanding to efforts to characterize the seafloor. We also introduce a new processing effort—a project aimed to develop tools for the automated detection of marine debris. Finally, we recognize our critical responsibility to manage and deliver the data that we collect in an appropriate fashion and thus discuss our efforts to develop state-of-the-art data management and delivery systems.

#### Improved Bathymetric Processing

##### CUBE and Improved Uncertainty Management

One of the major efforts of the Center has been to develop improved data-processing methods that can provide hydrographers with the ability to very rapidly and accurately process the massive amounts of data collected with modern multibeam systems. This data-processing step is one of the most serious bottlenecks in the hydrographic “data-processing pipeline” at NOAA, NAVO, and hydrographic agencies and survey companies worldwide. After evaluating a number of approaches, our efforts have focused on a technique developed by Brian Calder that is both very fast (10s to 100s of times faster than then contemporary processing approaches) and statistically robust. The technique, known as CUBE (Combined Uncertainty and Bathymetric Estimator), is an uncertainty model-based system that estimates the depth plus a confidence interval on each node point of a (generalized) bathymetric grid. In doing this, the approach provides a mechanism for automatically processing most of the data and, most importantly, the technique produces an estimate of uncertainty associated with each grid node. When the algorithm fails to make a statistically conclusive decision, it will generate multiple hypotheses, attempt to quantify the relative merit of each hypothesis and present them to the operator for a subjective decision. The key is that the

operator needs to interact only with that small subset of data for which there is some ambiguity rather than going through the conventional, very time-consuming process of subjectively examining all data points.

CUBE was subjected to detailed verification studies in 2003 as part of a cooperative research effort with NOAA that compared the automated output of CUBE to equivalent products (smooth sheets) produced through the standard NOAA processing pipeline. Verification studies were done in three very different environments (Snow Passage, Alaska; Woods Hole, Massachusetts; and Valdez, Alaska) involving surveys in various states of completion and comparisons done by NOAA cartographers. In each case, the CUBE-processed data agreed with the NOAA processed data within IHO limits. CUBE processing took from 30 to 50 times less time than the standard NOAA procedures in use at the time.

Based on these verification trials and careful evaluation, Capt. Roger Parsons, then director of NOAA’s Office of Coast Survey, notified NOAA employees, as well as other major hydrographic organizations in the U.S. (NAVO and NGA), of NOAA’s intent to implement CUBE

as part of standard NOAA data processing protocols. As described by Capt. Parsons in his letter to NAVO and NGA, CUBE and its sister development, The Navigation Surface:

*“...promise considerable efficiencies in processing and managing large data sets that result from the use of modern surveying technologies such as multi-beam sonar and bathymetric lidar. The expected efficiency gains will reduce cost, improve quality by providing processing consistency and quantification of error, and allow us to put products in the hands of our customers faster.”*

In light of NOAA's acceptance of CUBE, most providers of hydrographic software have now implemented CUBE into their software packages (CARIS, IVS3D, SAIC (now Leidos), Kongsberg Maritime, Triton-Imaging, Reson, Fugro, GeoAcoustics, HyPack, QPS, and IFREMER). Dr. Calder continues to work with these vendors to ensure a proper implementation of the algorithms as well as working on new implementations and improvements. The progress made in 2013 is described below.

### Multiresolution Grids—CHRT

Calder's efforts with respect to CUBE in 2013 focused on the CHRT (CUBE with Hierarchical Resolution Techniques) algorithm. CHRT is a software architecture for robust bathymetric data processing that takes the core estimator from the CUBE algorithm and embeds it in a system that allows for variable resolution of data representation which is data adaptive, meaning that the density of data collected is reflected in the resolution of estimates of depth generated. The architecture is also designed to be efficient, parallelizable, and distributable over a network. As part of the on-going development of CHRT, Calder has been conducting work in four areas: a fully-distributed version of the algorithm (major effort); transition to practice of the serial and single-processor parallel versions of the algorithm in conjunction with NOAA and Center industrial partners; improvements to the core algorithm to support interactive data analysis in implementation; and extensions to the algorithm to allow first-order slope correction based on preliminary robust estimates of surface parameters.

The CHRT algorithm is an outgrowth of the Center's work on high-speed, robust data processing techniques for high-density hydrographic data, most often collected by multibeam echosounder. The CHRT algorithm extends the CUBE estimator by providing a nested grid data structure that allows the resolution of data representation to adapt to prevailing conditions throughout the survey area of interest, and through robust estima-

tion techniques that predict automatically the required resolution based on the observed data. In a two-pass approach, CHRT starts with a coarse resolution estimate of depth and data, computes the appropriate resolution for data representation at regular intervals across the area of interest, and replaces the coarse grid with piecewise-constant finer resolution grids. A second pass through the data at the (varying) finer resolution completes the process and automatically preserves the appropriate level of detail in the source data for inspection by a human operator. Appropriate metrics are provided to key the operator's attention to areas of the data that likely require further work. In addition to better preserving the details in the source data, CHRT also removes significant amounts of operator interaction and uncertainty in setting up the computational problem, and avoids many common operator errors that could be problematic in CUBE usage. The result is a simpler, more efficient, and significantly more robust environment for computer-assisted hydrographic data processing.

In order to better integrate with modern computational structures for data processing, CHRT follows a client-server design so that the client application (e.g., a graphical user interface on a single workstation) is logically decoupled from the server application, which does the actual data processing. This design simplifies the interfacing requirements for client applications, but also allows for significantly better testability (even after field deployment) and allows for a number of different implementation scenarios for the server application without any modification to the client code.

There are five core problems in network distribution of the CHRT algorithm:

- How should the whole problem be split into segments that can be solved, as independently as possible, on individual computers?
- To what extent can the individual segments be computed in isolation, and how should the partial results be reassembled?
- How should these segments and their associated data be assigned to the available computational resources for maximum efficiency?
- How can the data resources required for computation of the segments be made available across the computational resources?
- How should the nodes in a computational cluster be discovered, managed and marshaled for the most efficient use of resources?



The first two problems were addressed in prior reporting periods through the implementation of a single-computer parallel version of the algorithm (see 2011 and 2012 progress reports). In essence, the design of CHRT is such that any arbitrary area can be sectioned at the scale of the coarse-resolution grid of the first phase of the algorithm and therefore it is a simple matter to determine where to make the split in order to optimize the segments for even balance of expected computational load. The CHRT algorithm uses a constrained data density-weighted branch and bound algorithm to compute the segmentation for a given number of processors (or computational threads if running in parallel on a single machine). Similarly, so long as all required data is available, segments constructed in this fashion do not need to communicate with each other in order to complete their computations; since the segments are disjoint, the results assembly is logically trivial (although complex in implementation). In 2013, Calder has therefore focused on the last three problems: scheduling of the algorithm (major effort), data availability, and the assembly and management of clusters.

### Scheduling of the Algorithm

For CHRT, the scheduling problem occurs in two ways: scheduling which data to process on each available computer for the first phase of the algorithm, and selecting which segment of the second phase to schedule on each available computer. The problems interact with each other and, in a strict sense, there is no means to determine a jointly optimal solution. There is no one algorithm that will provide an optimal schedule of source data lines, or segments of the second phase, to computers and, indeed, the success of any one algorithm is likely to depend strongly on the size and nature

of the data set being scheduled. The CHRT algorithm has therefore been designed to have a flexible scheduler so that multiple algorithms can be used to respond to these complex conditions. As an overall structure, the algorithm attempts to schedule the source data lines for the first phase of the algorithm so as to provide the most even distribution of work over the available computers (work is estimated by the number of source soundings to be processed in each line), taking into account, where possible, spatial adjacency of lines (since lines that are close in space are more likely to be required within a segment during the second phase, and therefore would benefit from being scheduled on the same computer during the first phase). Once the segmentation of the second phase is computed, the algorithm then attempts to assign the segments to the available computers, given their known source data line availability, so as to minimize the potential for a pipeline stall when reading source data for the second phase.

To test the efficiency of the first phase distribution, four different scheduling algorithms were used (in increasing order of complexity): a random scheduling algorithm; a weighted random scheduling algorithm; MULTIFIT—a well-known algorithm for assigning tasks to a known number of bins and; MULTIFIT+COM—an adaption of MULTIFIT used to deal with the placement of algorithms where tasks communicate with each other. The algorithms were tested against each other by scheduling 9.2 million soundings (which comprise NOAA Survey H11825 in the vicinity of Ernest Sound, AK) and using the predicted speed-up (i.e., ratio of time to compute the answer on a single computer to the time taken on the distributed array) as a measure of

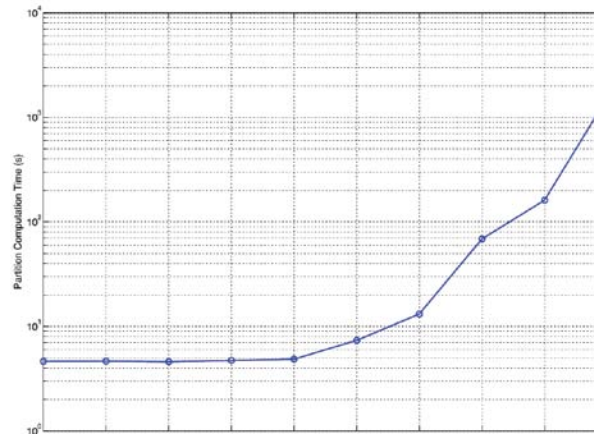
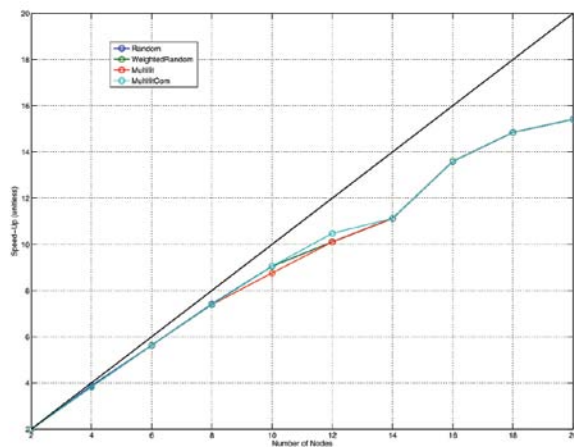

Figure 4-1. (left) Speed-up of overall computation for all four first phase scheduling algorithms and different numbers of computational nodes. The black line indicates ideal speed-up (i.e., linear in the number of nodes). (right) Time to compute the optimal segmentation for the second phase of CHRT for different numbers of threads (in parallel) or computers (distributed). Note the logarithmic vertical scale—the computation cost rises steeply for higher numbers of segments.

efficiency of the scheduling. In all cases, the processing rate and transfer rate for data were determined from experiments with the serial version of CHRT.

For different numbers of computers in the cluster (Figure 4-1, left), it is clear that, although slightly sub-optimal (as is expected—there are always overheads), the speedup is close to the nominal linear speed-up for low numbers of computers, and continues to increase as the size of the distributed cluster increases. This shows that committing more resources to the computational task continues to reduce the overall computation time, although inefficiencies in placement (especially in the second phase) start to have a toll with larger clusters. These findings, in conjunction with the time taken to compute the optimal segmentation for the second phase for higher numbers of computers (Figure 4-1, right), suggest that there may be a practical upper limit for number of computers that can be effectively used for any given computation. An immediate corollary of this is that, for efficiency, the cluster of computers assembled to carry out a computation should be dynamically sized based on the computation to be attempted, rather than being statically assigned.

Additional experiments revealed that computation time for the scheduler is not expected to be a significant problem since it is generally small (although it grows with the number of lines being scheduled) and that the dominant factor in overall performance was the stall time. This suggests that it should be possible to improve matters by ‘pre-warming’ the cache of available source data lines at each computer ahead of the second phase of the algorithm starting by transferring copies of lines likely to be required while the first phase is still being computed. Until the first phase completes, however, there is no indication as to which lines will be required. An approach to this problem is to send the first few biggest lines, since they are the most likely to cause stalls (they take longest to transfer) and are most likely to be processed first due to the policy of sorting the lines according to size before scheduling them. Figure 4-2 shows the results of changing the number of lines sent to all nodes (the ‘pre-warm depth’) on the worst-case stall time observed. Here, the MULTIFIT+COM algorithm, since it uses communications costs to co-schedule lines that are spatially adjacent, is better able to take advantage of the pre-warming to minimize stall times, although the overall performance improvement is modest (order 2-3%) due to the small stall times observed in this case. An improvement in stall time as a function of pre-warm depth is also observed to be significant as the processing rate at each computer is increased (by increasing

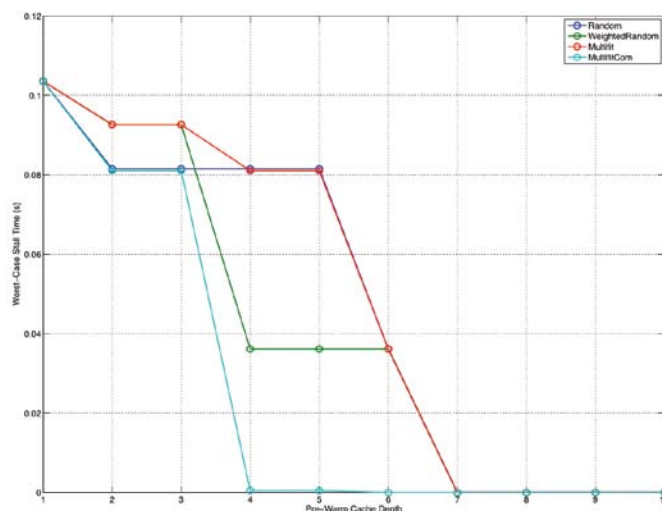

Figure 4-2. Observed worst-case stall time in second phase of CHRT as a function of scheduler and cache pre-warm depth (i.e., number of lines pre-staged on all computers). The more sophisticated algorithm of MULTIFIT+COM can take better advantage of the pre-warming, although the absolute difference in time is small in practice.

the parallelism within each computer). Again, the overall effect is small (order 10-12%).

These observations suggest that the selection of scheduler can have some effect on the efficiency of the computation, although the expected difference is relatively small compared to the overall speed-up. However, there is sufficient evidence to conclude that this outcome is dependent on the size of the computation being scheduled, and the specifics of the data. Consequently, it is likely that an efficient general algorithm will need to be adaptive in choosing the scheduler, with one adaptation possibility being to use simpler schedulers for small problems, and more complex schedulers for larger ones.

The observations from these experiments also have implications for the design and implementation of the overall algorithm. For example, the schedule computation costs resulted in the use of dynamic clusters, where the number of nodes to be used can be set for each computational effort, and allowing sub-computations to be moved from computer to computer in order to rebuild a cluster for further processing if required. Similarly, the algorithm has uncommitted scheduling which can be changed at run-time, and uses databases extensively to track the computation in order to improve robustness to individual computational node failures. The design of the distributed algorithm has been completed.

## Data Availability

The second problem addressed in 2013 was that of data availability. In essence, each computational node must be able to access any source data line in order to be able to support an arbitrary segment of the second phase, but cannot guarantee that the line will be available at the end of the first phase. Consequently, the nodes must be able to fetch source data from suitable hosts; to improve efficiency, and reduce network bottlenecks, this should include their peers. In addition, since clusters are constructed dynamically, partial sub-computations need to be mobile between computational nodes since there is no guarantee that the same set of nodes will be available when the cluster is reformed to carry out further computation on the same survey.

This problem is in essence that of a distributed file system. Although there are a number of possible solutions to this available as open or closed software libraries, availability of cross-platform and low-complexity architectures is limited. Consequently, Calder has designed a heavily simplified algorithm that allows a controller node to track which source data lines are available at which computational nodes, and therefore to instruct the computational nodes where to source data when required. The controller node also acts as the front-end server for client connections, marshaling the computational nodes, computing the schedule for the first phase and segmentation for the second phase, etc., and, therefore, always has the required information

to make the assignments and direct transfer of data. This dual role radically simplifies the implementation of the system so that it becomes, essentially, a pre-fetch task at each node, driven by the front-end server. The preliminary implementation of this has undergone significant development, and is currently being tested with the rest of the distributed CHRT algorithm.

## Composition and Management of a Cluster

An inherent complexity of the CHRT approach is the requirement to discover, and then marshal, the individual nodes in the cluster, manage persistence of partial products and sub-grids, and sequence the events of the CHRT algorithm when applied to a group of nodes (while still preserving the ability to run in parallel on each node, and to run as a single server on one node if required). The design of these features has been completed, and an implementation of the first phase of the algorithm, which includes a new testing environment that simulates a cluster on a local machine, is being tested with the rest of the distributed CHRT algorithm.

## Implementation and Testing of CHRT with Industrial Partners

The CHRT algorithm has been licensed under a cooperative development model that is intended to ensure that what is finally implemented in commercial software is the same algorithm that was tested in research and during development. Under this model, the

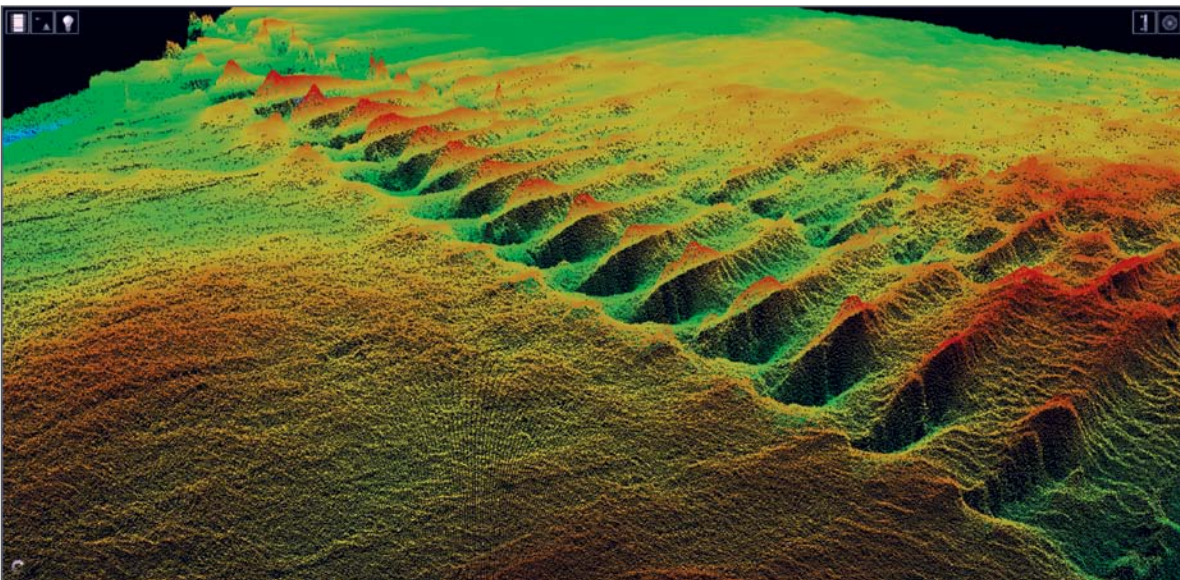

Figure 4-3. Visualization of an early CHRT hierarchical surface in CARIS software (in this case of bridge supports). The co-development model encourages early adoption of software and synergies between developers and testers that can benefit the whole community, and ensure correct transmission of algorithms from research to operations. (Data courtesy of Bill Lamey, CARIS and Jack Riley, NOAA.)



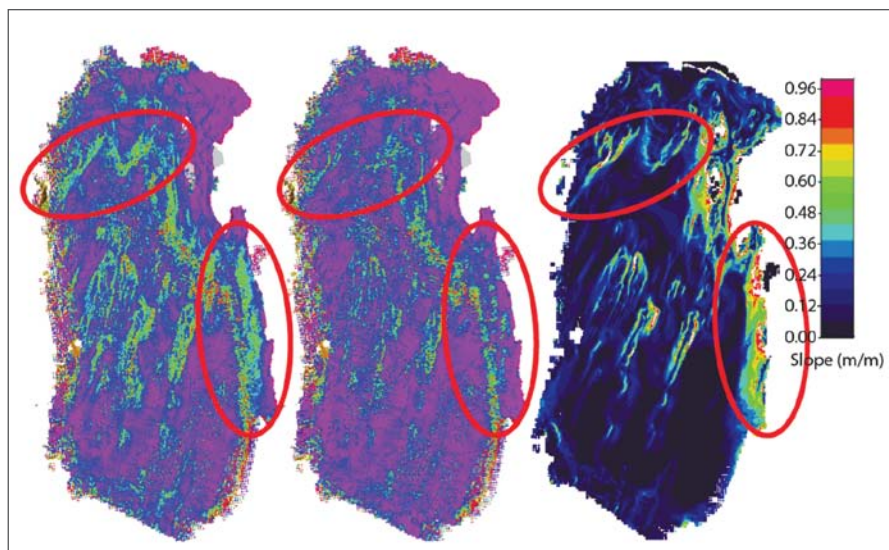

Figure 4-4. Visualization of the effects of first-order slope correction on CHRT depth uncertainty estimates. *Left*: color-coded uncertainty from the current algorithm; *Middle*: color-coded uncertainty from the modified algorithm. *Right*: slope of the estimated bathymetry. Note the significant reduction in estimated uncertainty due to the slope corrections in areas where slope is significant.

Center's Industrial Partners use a common source-code repository as a starting point for their implementation, and agree that any implementation must pass a common test-suite in order to be labeled CHRT.

The co-development model has now been implemented, with IFREMER, CARIS, SAIC (Leidos), Alidade Hydrographic, and QPS as the first five licensees. The source code has also been made available to NOAA/HSTP in order to allow them to test the code and provide feedback on observed difficulties and desired functionality. NOAA/HSTP have a formal testing plan in place, and regular teleconference meetings have been held with Calder and NOAA colleagues to progress the testing. This process has already driven out a number of bugs that had not been exercised with the original small test data set, and has gone some way to proving the utility of the co-development model. Significant developments of the code, in particular supporting better cross-platform compilation (specifically, through better OpenGL handling), better error reporting, and improvements to the resolution determination algorithm that avoids duplicate nodes, have been implemented as a result of interactions with the Industrial Partners. Co-developers have also submitted documentation on best practices, which have been included into the project's wiki, and methods to build the test suite for the code are under investigation.

A side-benefit of the co-development model is that Industrial Partners gain access to the code early so that

they can better schedule and align development of their own products as the CHRT algorithm improves. As a particular example, Calder, NOAA colleagues Riley, Miller and Froelich, and CARIS co-developer Bill Lamey authored a paper for the U.S. Hydrographic Conference in March 2013 that included early visualizations of CHRT hierarchical grids (Figure 4-3) developed by Lamey to assist Riley et al. in their testing of CHRT. As more developers start to be involved, these sorts of synergies are expected to increase.

### Core Data Visibility

The CHRT algorithm attempts to report the 'correct' depth estimate as often as possible, but there will always be cases where this is impossible, and where detailed scrutiny of

the results of the algorithm are required. At the request of the NOAA testing group, Calder has therefore added the ability to extract very detailed information about all hypotheses of depth that CHRT constructs and report it to the user-level interface. This also supports the visualization requirements for commercial implementations.

### First-Order Slope Corrections

At its core, CUBE, and therefore CHRT, assumes a locally flat seafloor. This has implications for the number of hypotheses on true depth that are generated by the algorithm in areas of steep slopes. Attempts at slope corrections in CUBE have been implemented in the past, but the results have always been limited due to the lack of robust information on slope available to the algorithm. As part of the Center's summer intern program, Julien Ogor (a French hydrography student) developed a method for robust surface construction and slope estimation under Calder's supervision, and Calder implemented the necessary infrastructure within CHRT to allow Ogor's surface estimates to be added to the algorithm's estimates. (This included upgrades to the memory management system that were also required to support dynamic re-running of the algorithm under normal circumstances, a key request from the co-developers.) Extensive experiments on algorithm performance showed that the technique significantly improved the uncertainty estimates where slope had a major effect on the algorithm (Figure 4-4), and also

improves the other metrics that the algorithm provides to the user to qualify how good the estimate of depth is believed to be. The experiments also provided useful insight into the appropriate settings for the algorithm parameters that will carry over to all applications of CHRT. The version of CHRT with slope corrections is now available for use, on an experimental basis, by CCOM Industrial Partners who are implementing the algorithm; full adoption into the core code would require rebuilding of Ogor's algorithm in C++ but is, in principle, possible.

## Improvements in Multi-Sector MBES Georeferencing

As manufacturers strive to improve the performance of MBES, the innovations introduced sometimes lead to unexpected (and detrimental) consequences. One example of this is the introduction of multiple sectors across the multibeam swath to permit more precise yaw compensation that has made georeferencing of the soundings much more complex. Beaudoin has been collaborating with colleagues at the University of New Brunswick's Ocean Mapping Group (OMG) to develop an improved multi-sector georeferencing algorithm for the UNB SwathEd software suite. The conic intersection method currently in use in SwathEd introduces bathymetric artifacts at the sector boundaries in cases where the multibeam system is aggressively stabilizing for yaw. This is largely due to the method's simplifying assumption that the transmitter and receiver are co-located in space. This assumption typically introduces negligible error in cases where the total water depth is large relative to the transmitter/receiver separation distance. A UNB graduate student under Beaudoin's supervision has investigated a new approach that circumvents the simplifying co-location assumption by treating the problem as the geometric intersection of hyperbolas on the seafloor. An iterative approach is taken where a model of the sounding geometry is recreated so that approximately scaled transmit and receive hyperbolas are corrected for motion and refraction effects to estimate the 3D beam pointing vector to the intersection point. The scale factor and refraction correctors in the mathematical model are iterated until negligible and the final output is the fully motion corrected and ray traced position of the beam footprint on the seafloor. Initial results are very promising with a very close match to the output of the proprietary Kongsberg Maritime sounding reduction algorithm. This new algorithm is expected to improve the community's ability to apply sounding correctors in post-processing with full knowledge of the underlying algorithm.

## Improved Processing for Phase-Measuring Bathymetric Sonars

Phase-measuring bathymetric sonars (PMBS) (multi-row sidescan sonars that look at the phase differences of the acoustic signals between the rows to derive a bathymetric solution) have the potential of offering much wider coverage in shallow water than conventional beam-forming multibeam sonars. NOAA and other mapping agencies have recognized this potential benefit and have begun to explore the feasibility of using PMBS as a hydrographic tool. One of the immediate results of this is the realization that current hydrographic processing software approaches and tools are cumbersome to use with the very dense, but inherently noisy data produced by PMBS. The Center has committed itself to exploring new approaches to processing PMBS data and, in support of this commitment, has teamed with the University of Delaware in the operation of a 500 kHz GeoSwath PMBS that is mounted on a Gavia Autonomous Underwater Vehicle. This has provided us the opportunity to collect PMBS data and begin to explore the problems associated with PMBS data (as well as AUV-derived data). Our experience in recent years with PMBS expanded to include work with the Klein HydroChart 5000 and the EdgeTech 4600 and also included involvement from Xavier Lurton of IFREMER.

Val Schmidt has taken the lead in exploring problems with (and new approaches to) processing PMBS bathymetric data. Working with data collected by the 500 kHz GeoSwath system aboard the Gavia AUV (see AUV section), he has collaborated with Tom Weber and others to understand the uncertainty associated with PMBS data and develop robust processing tools. GeoSwath data is particularly difficult to process, because no filtering is done during data acquisition that might mitigate the volume and complexity of data. The system produces almost 4000 raw measurements per port/starboard ping pair. It is not surprising that data from phase differencing systems appear to be noisy when compared with multibeam system as MBESs average many measurements with each bottom detection. The volume and quality of PMBS data make the processing task lengthy, error prone and almost impossible to repeat where standard methods are used. Therefore, we have endeavored to create a semi-automated, physics-based processing package capable of filtering the data for outliers, estimating the uncertainty of the remaining measurements, and combining the measurements in an optimal way to produce seafloor sounding estimates similar to that of multibeam systems.

Schmidt's algorithm, written in MATLAB, begins with the Most Probable Angle Algorithm including a despiking routine for filtering. Uncertainty is estimated for each sounding using a method similar to the Quality Factor method proposed by Xavier Lurton (a visiting scholar from IFREMER) for multibeam systems (see discussion above). Finally, given a user-specified maximum depth uncertainty, individual measurements are combined in a weighted mean until their combined uncertainty falls below the desired depth uncertainty. Sounding estimates are then written to GSF files for further processing in CARIS or other similar software packages.

Because data are processed to meet a depth uncertainty requirement, this new model inverts the goals of traditional survey methods. Rather than producing a survey and subsequently inspecting the survey to see what portion meets the desired IHO requirement, one may specify the IHO requirement and process the data to meet it (though it may not meet other requirements such as resolution). Such a method may be extensible to standard multibeam systems and is a subject of ongoing research.

In 2013, our ability to take part in the ONR-funded Bedform Survey Program at Redbird Reef afforded an opportunity to compare the Most Probable Angle Algorithm with a standard bathymetric processing approaches as utilized by NOAA in the Caris processing package. A single phase-differencing sidescan dataset was processed by each of the algorithms and the difference in the two resulting surfaces (MPAA-Caris) was calculated (Figure 4-5). The general trend of green indicates a +0.05 m bulk difference between the surfaces whose cause remains unknown. Troughs of the bedforms appear blue indicating that the MPAA surface is slightly deeper (approximately 15 cm) than the Caris surface. Because the effect is uniform across the surface where bedforms exist and uncorrelated with the geometry of the measurement or track of the vehicle it is likely that MPAA outlier rejection is capturing the seafloor with greater fidelity than the Caris method. Subway cars and wrecks appear as purple features in the plot. Closer inspection of these large objects in a profile view (Figure 4-5) shows a roughly equal number and magnitude of differences between the surfaces above and below zero. The equal number and magnitude of positive and negative differences seems to indicate no clear advantage of either method over potential obstacles to navigation.

Also in 2013, we began to evaluate the L3/Klein Hydrochart 5000 bathymetric sidescan sonar for use

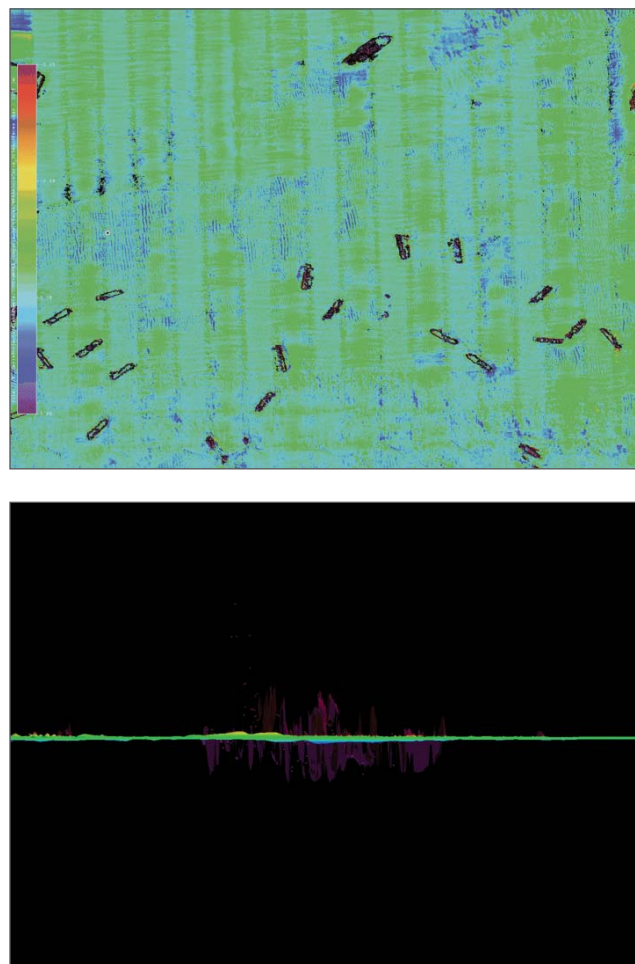

Figure 4-5. Difference surface between data pre-processed with the Center's MPAA algorithm and Caris standard methods (top). Profile view of a sunken trawler in this surface shows roughly equal distribution of differences above and below using the two methods (bottom).

in hydrographic surveys. Val Schmidt, working with Christy Fandel (now a NOAA Office of Coast Survey employee) began a pre-mission planning assessment of the Hydrochart to better understand its capabilities for the purposes of post-storm surveys. Fandel conducted a field trial survey of the system providing a surveyor and data processor's analysis, while Schmidt made a more quantitative assessment of the data itself.

Sounding uncertainty estimates are critical to the quantitative assessment of hydrographic surveys. However, it was found that, while the Hydrochart provides real-time uncertainty estimates for their bathymetric data, these estimates were misinterpreted and misapplied within Caris. This prevents the traditional processing and analysis methods used by NOAA for scrutinizing surveys for IHO compliance and other quality measures. In collaboration with Klein, the Center provided



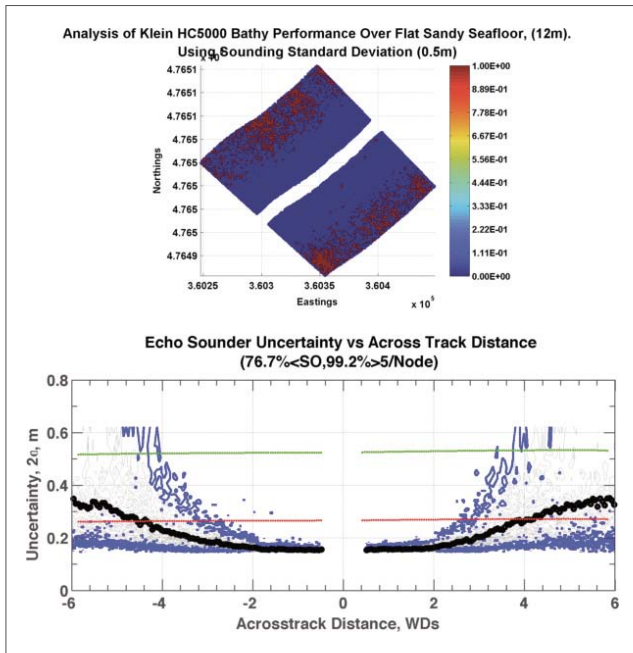

Figure 4-6. Data collected over a flat sandy seafloor of 13 m depth to empirically assess the sounding uncertainty of the Hydrochart 5000. Sounding uncertainty, measured as the standard deviation of the data in each 0.5 m grid cell, is plotted in the lower plot as a function of across-track depth (95% confidence intervals are shown in blue), along with IHO Special Order and Order 1 limits (red and green curves respectively). In the upper plot, a graphical display of which grid cells would meet IHO Special Order is shown (a total of ~78%). Only a gross-outlier filter was applied in post-processing for this analysis.

Caris detailed instructions on the proper use of Klein’s uncertainty information within the total propagated uncertainty library provided by CUBE. Since traditional data processing tools failed to properly interpret Klein data, the data was parsed and analyzed in MATLAB manually. Klein uncertainty estimates were found to follow the general trend of the actual data uncertainty over a flat seafloor, and models of phase-differencing sonar performance published by Lurton and others in recent years were applied and also generally agreed with uncertainty in the actual data.

Under nominal conditions with no filtering, 77% of the grid cells produced from a single 150 m swath of data were found to achieve special order levels (Figure 4-6). With guidance from Megan Greenaway (NOAA employee stationed at the Center) and Katrina Wylie (NOAA survey technician and student at the Center) the results were compared against metrics used by NOAA for evaluating survey data products for IHO compliance and sounding density.

It was noted that Klein systems produce a large nadir gap (+/- 30 deg.), greatly decreasing their survey

efficiency. Ongoing work includes investigation of signal processing methods by both Klein and the Center to produce better nadir coverage, as well as efforts to better understand the impact on seafloor features of smoothing done by Klein to reduce measurement noise.

In addition to work with Klein, Brian Calder and Val Schmidt have begun an effort to review the methods by which sonar uncertainty is estimated in the TPU library frequently distributed with the CUBE algorithm. The intent is to provide to the community clear paths to take when faced with any of several scenarios regarding sonar uncertainty. Legacy sonars typically provided no sounding uncertainty information. Rather, a semi-empirical model for multibeam systems (only) was used to estimate sonar uncertainty. This model was provided by Kongsberg in 1995 for the initial version of the Hare-Godin-Mayer report on bathymetric uncertainty. Modern sonars, however, may provide measurement uncertainty along with their soundings. These may come in the form of angle measurement uncertainty, range measurement uncertainty, or both, or alternatively IFREMER-style Quality Factors and sometimes other proprietary metrics. Our hope is to clarify how these should be used within the TPU algorithm and to revise the semi-empirical model with a more modern understanding of sonar performance generalizing it to encompass phase-differencing sidescan bathymetric systems as well.

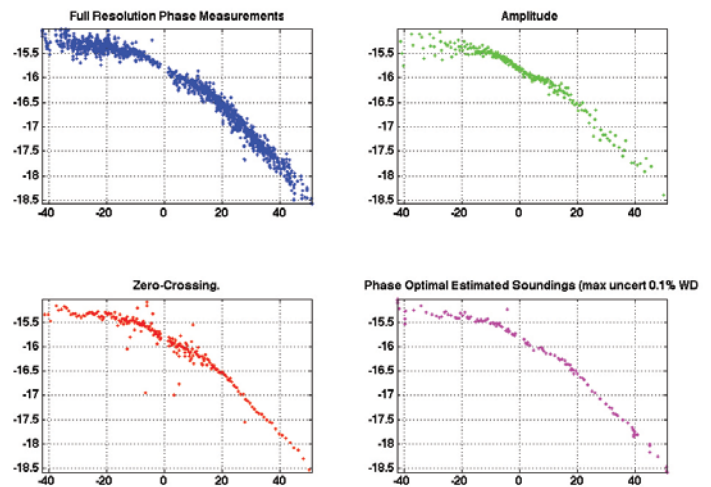

Figure 4-7. Raw I/Q data from a Reson 7125 has been beam formed and processed to produce traditional amplitude bottom detects (green), zero-crossing bottom detects (red). In addition, individual phase measurements of the bottom return within +/- 1/2 beamwidth of the zero-crossing detect in each beam have been stitched together (blue). “Optimal” soundings with a 0.1% depth uncertainty limit have been created from these individual measurements as described in the text (magenta).

## Balancing Resolution and Uncertainty in Bathymetric Sonar Systems

In Schmidt's PMBS processing approach, the uncertainty is first estimated for each measurement and then individual measurements are combined in a weighted mean until their combined uncertainty falls below a user-specified depth uncertainty. Because only enough soundings are combined as are required to meet the uncertainty threshold, across-track resolution of soundings can be optimized for the SNR and environmental conditions automatically. Now this method is being extended to multibeam sonar systems.

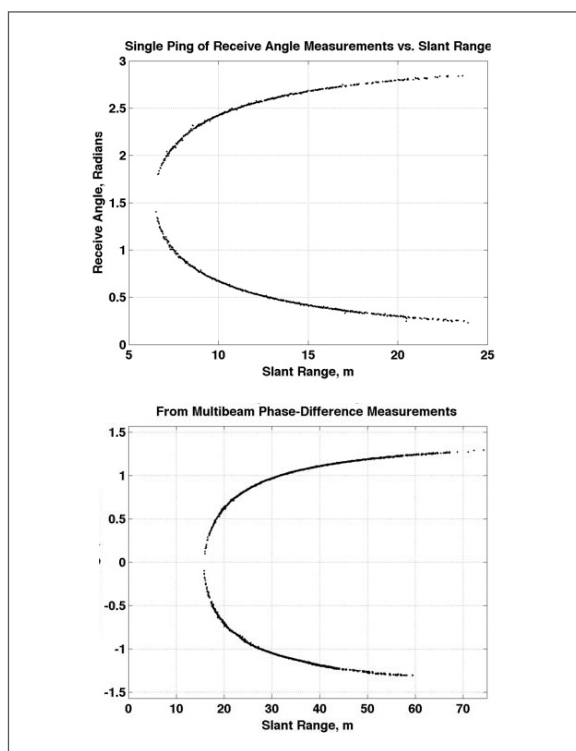

Figure 4-8. Receive angle vs. range is plotted from a ping of phase-differencing sidescan data (*top*) and individual sup-aperture phase-difference measurements stitched together from all beams of a multibeam (*bottom*). Data processed in this way may be optimally combined to maximize the resolution within an uncertainty constraint.

Away from nadir, bathymetric sonars also use phase-difference measurements to determine depth. These phase-difference measurements are identical to those made by phase-differencing sidescan sonar systems and, although not typically done, each individual measurement in the phase-difference ramp indicates the location of the seafloor relative to the broadside of the beam. Therefore, rather than fitting a curve to the phase-ramp to pick a single sounding for the beam,

one can create soundings from each individual phase measurement. The result is noisy, similar to the raw measurements of a phase-differencing sidescan (Figure 4-7). However, the phase measurements can be converted to receive angle relative to the sonar and then combined using a method identical to that used for phase-differencing sidescan systems described above. The results of such an application are shown in Figure 4-8.

Because data are processed to meet a depth uncertainty requirement, this new model requires a reassessment of conventional processing methodology. Rather than producing a survey and subsequently inspecting the survey to see what portion meets the desired IHO requirement, one may specify the IHO requirement and process the data to meet it. In addition, rather than having a fixed number of soundings per ping, the number of soundings and their spacing across the swath automatically adjusts as the uncertainty in the measurements changes. Where the SNR is high and the uncertainty is low, one may achieve the full resolution of the sonar for the given beamwidth, transmitted bandwidth and sample rate. Conversely, where the SNR is low and the uncertainty is high, more measurements must be combined to meet the uncertainty threshold and fewer soundings result.

## Sound-Speed Profile Uncertainty Estimation and Management

It is becoming increasingly apparent that our ability to measure and compensate for the spatial and temporal variability of the sound-speed profile is a fundamental limitation in our ability to collect consistently high-quality seafloor bathymetry data and the largest single remaining source of uncertainty within our measurements. Jonathan Beaudoin has been leading several efforts focused on developing methods to assess the uncertainty in sounding due to the variability in the sound-speed profile (SSP).

### SVP Editor/Server/Refraction Monitor

As part of these efforts, and in conjunction with an NSF-sponsored project to support the UNOLS multi-beam fleet (see discussion of MAC under SENSORS Theme), Beaudoin has developed an "SVP Editor" (Figure 4-9). The SVP Editor is an application that provides pre-processing tools to help bridge the gap between sound speed/CTD profiling instrumentation and multi-beam echosounder acquisition systems. The main goal of the software is to standardize and streamline the processing of oceanographic information that is col-

lected in support of multibeam echosounder refraction corrections. The software, including the source code, is publicly available online (<http://mac.unols.org>). Early testing of the server functionality was done in 2011 by Steve Roberts of USCGC *Healy* and Steve Brucker of CCGS *Amundsen*. Since then, the SVP Editor has been installed on R/V *Kilo Moana*, R/V *Marcus G. Langseth*, R/V *Hugh R. Sharp*, NOAA Ship *Okeanos Explorer*, and R/V *Falkor*, NOAA Ship *Ronald H. Brown* (Armstrong, Calder), NOAA Ship *Pisces* (Weber, Beaudoin, Rice, Wilson) and R/V *Atlantis* (Welton).

Since the last progress reporting period, the SVP Editor has been upgraded to allow sound speed profile transmission to QINSy and reception ability from the Moving Vessel Profiler (MVP). Developments are currently underway to add support for SVP data transmission to Hypack and PDS2000. The SVP Editor was installed on NOAA Ship *Rainier* along with CastTime in early 2013 as an additional tool to improve real-time refraction corrections with *Rainier's* EM710. During troubleshooting investigations with NOAA Ship *Rainier's* EM710, it was determined that the sound speed measurements from the ship's MVP200 were inadequately extended in areas where water depths exceeded the MVP's ability to sample when operating at typical survey speeds. This was leading to systematic refraction artifacts in the real-time ray tracing corrections. The SVP Editor was modified to capture network transmissions of the MVP casts and a suggestion was made that the ship install SVP Editor to allow operators to better visualize and extend sound speed profiles prior to delivery to SIS since the default profile extension that occurs in

SIS was proving inadequate. A set of recommended procedures was provided to the vessel to make the best use of the MVP in a variety of scenarios. Further modifications to SVP Editor allow automated export of the MVP measurements to a Caris HIPS .svp file such that the nightly SVP post-processing benefits from the additional QA and QC steps that are taken in real-time. It is anticipated that the basic cast extension functionality and QA/QC abilities offered by SVP Editor will be discussed with HSTP to see if they can be incorporated into Velocipy.

## Hydrographer's Weather Map

Carrying the approach to using oceanographic models in aid of seafloor mapping one step farther, Beaudoin is working on developing tools to help better understand the "underwater weather" that can severely limit the achievable accuracies of echosounding data, particularly with wide swath multibeam systems. The result of this effort is something akin to a weather map that allows hydrographers to visualize oceanographic models in terms of refraction based uncertainty (Figure 4-10). The basic idea is that oceanographic models of temperature and salinity may be able to provide some idea of where and when spatial variability in the water column can be problematic.

Early work by Beaudoin focused on spatially and temporally coarse oceanographic models such as the World Ocean Atlas (WOA); the same methods have now been applied to time-varying, mesoscale resolution oceanographic models. Beaudoin further developed

the concept by applying his ray tracing spatial variability analysis to the Real Time Ocean Forecast System (RTOFS). The procedure is to express local oceanographic variations in terms of resulting sounding uncertainty through a ray tracing simulation using a set of sound speed profiles derived for a selected location and the immediate neighboring grid cells in an oceanographic model grid. The discrepancy amongst the final ray traced depths indicates the impact of the spatial variability at that location; this value is then computed throughout the spatial domain of the model and presented as a "weather map" which highlights areas of high spatial variability as uncertainty fronts where hydrographers must work harder to sample oceanographic variability.

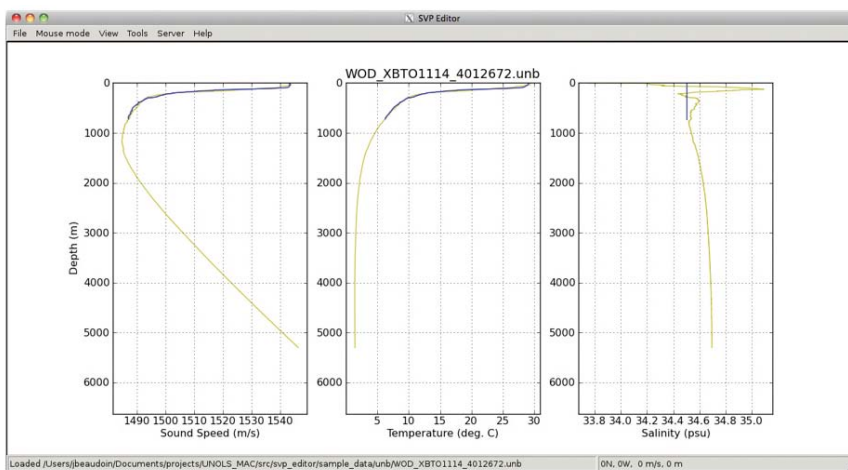

Figure 4-9. SVP Editor main graphical user interface showing plots of sound speed, temperature and salinity versus depth (left to right, respectively) for a CTD (yellow) and XBT (blue). In this particular scenario, the CTD is a reference cast that can be used to augment the XBT measurement with salinity and vertically extend the XBT to greater depth.



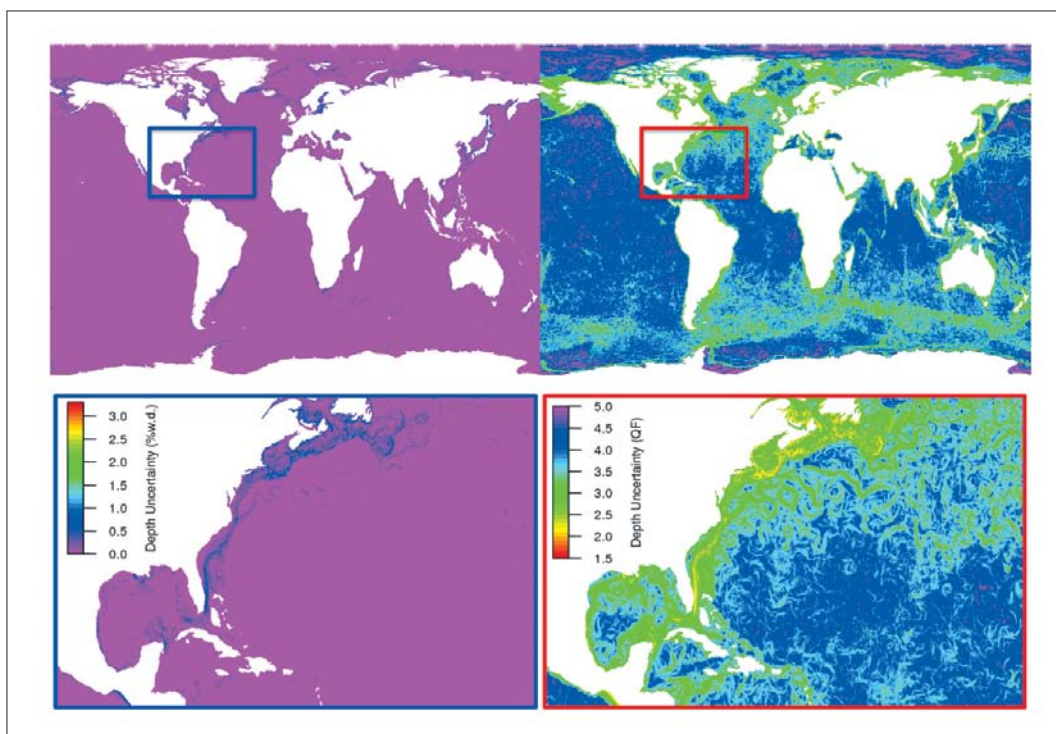

Figure 4-10. Linear vs. logarithmic representation of depth uncertainty (*left* and *right*, respectively). A worldwide analysis gives maximum depth uncertainties of  $\sim 3.5\%$ w.d., however, these locations are in the minority, thus a linear color scale that spans the range 0-3.5%w.d. does not allow for an appreciation of all the information that the analysis could be providing as the majority of the analysis output is below 0.5% w.d. Expressing the depth uncertainty logarithmically enhances the detail in the Weather Map analysis. In this particular example, the variability due to mixing at the continental shelf break dominates the linear image, whereas the meanders of the Gulf Stream are barely discernible, being roughly an order of magnitude weaker. The logarithmic representation enhances both types of variability.

With models such as RTOFS, it is possible to compute forecasts with higher spatial resolution and with, hopefully, increased fidelity over products generated from analyses using models such as WOA that provide only historic monthly means and thus have no nowcasting or forecasting capability.

In 2013, there was continued development and refinement of the SVP Weather Map concept. New developments include the use of the Ifremer Quality Factor scale for improved visualization (Figure 4-11) and automated production of Google Earth KMZ files for improved usability of the Weather Map products in survey planning and acquisition. Other work using the World Ocean Atlas climatologies included examination of the potential for the climatologies to quantitatively determine optimal seasons for hydrographic work in areas where oceanographic variability has a strong seasonal signature.

The Weather Map concept was presented, along with potential applications, at the 2013 U.S. Hydrographic Conference in New Orleans, LA.

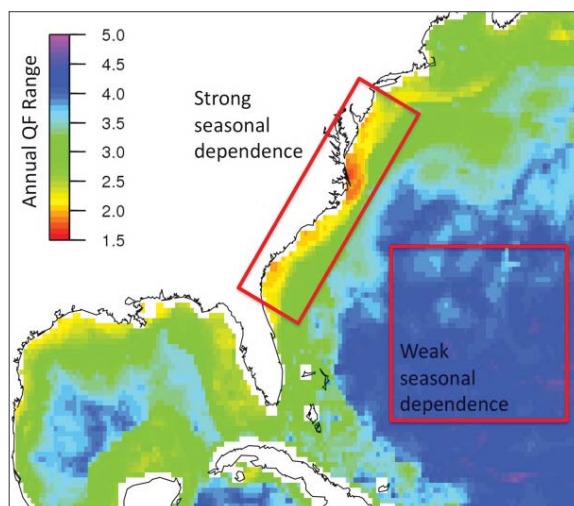

Figure 4-11. Annual range of Quality Factor (QF) based on WOA2001 ( $1/4^\circ$ ) ray tracing monthly analyses. Areas with strong seasonal effects exhibit a large difference between the highest and lowest QF over the course of the year, e.g., the inner shelf along the eastern seaboard. The WOA predicts weak seasonal dependence in the open ocean.

## Evaluation of Uncertainty in Bathymetry, Navigation and Shoreline Data from Photogrammetry or Satellite Imagery

Also covered within the PROCESSING theme are various efforts aimed at developing better ways to extract information about bathymetry, navigation, and shorelines from photogrammetry or satellite imagery.

### Shoreline Uncertainty Analysis

The National Shoreline depicted on NOAA nautical charts serves a multitude of purposes, from supporting safe marine navigation, to legal boundary determination, to use in a variety of coastal management and science applications. To support the accurate depiction of the national shoreline, NOAA's National Geodetic Survey (NGS) needs to understand the uncertainty associated with their determination. Initial collaborative approaches to assessing their uncertainty.

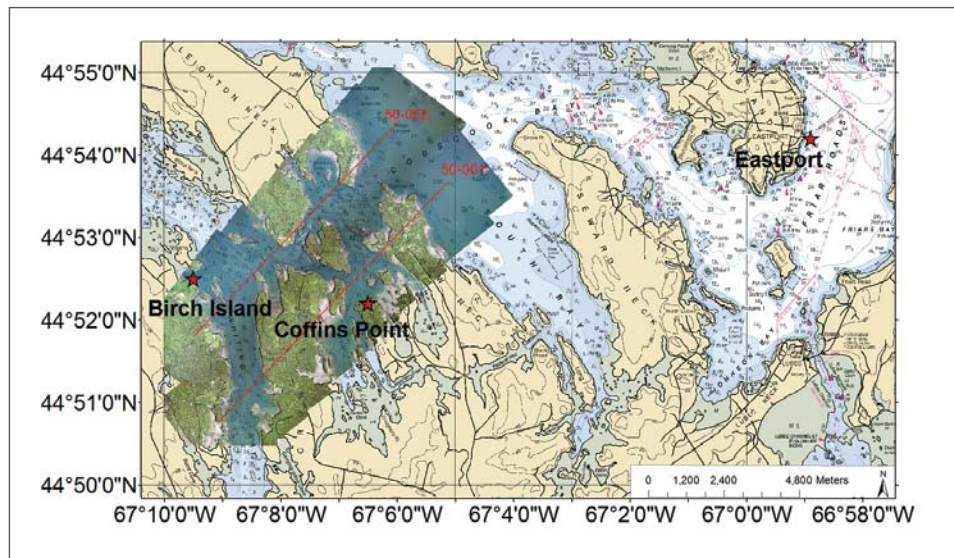

Figure 4-12. Natural color imagery overlaid on NOAA Chart from Downeast Maine region.

One of the most successful examples of research collaboration between the Center and NGS to date is the ongoing work on shoreline uncertainty modeling. The first phase of research collaboration between NOAA/NGS and the Center on shoreline Total Propagated Uncertainty (TPU), conducted in 2010-2011, focused on NGS's lidar-based shoreline mapping workflow. Since then, Parrish and Center colleagues have extended this work to compute the TPU of photogrammetrically-measured fixed points, based on uncertainty in camera position and orientation parameters and image measurement. This work resulted in development of the "EO TPU Tool" and a set of standard operating procedures (SOP) for production use of directly-georeferenced aerial imagery in NGS' Coastal Mapping Program (CMP). At the October 2012 meeting of NGS's Coastal Mapping Board (CMB), these procedures were approved for use in the CMP, enabling use of directly-georeferenced imagery, without aerotriangulation, in certain coastal projects. MP coastal compilers have begun using the new SOPs and the EO TPU Tool, and report that time savings are already being achieved. Simultaneously, LTJg Russell Quintero, NOAA's JALBTCX representative, is adapting the tool for possible use by the U.S. Naval Oceanographic Office.

As part of the graduate research of M.S. student Fang Yao, the shoreline uncertainty work is currently being extended to rigorously model uncertainty in mean high water (MHW) and mean lower low water (MLLW) shorelines mapped photogrammetrically from both tide-coordinated and non-tide-coordinated aerial imagery. A TPU model was developed for a test site encompassing the strait linking Dennys Bay, Whiting Bay and Cobscook Bay in the "Downeast" Maine coastal region (Figure 4-12). A key component of this work involved identifying and modeling the primary component uncertainties in photogrammetric shoreline compilation, including exterior orientation (EO) element uncertainty, water level uncertainty, human compilation uncertainty, and, in the case of tide-coordinated imagery, the offset between the tidal datum and actual water level at the time of imagery acquisition.



Despite the challenging conditions at the test site, which included a wide range of beach slopes and very large tidal range, the estimated shoreline TPU was found to be well within the IHO S-44 standards for uncertainty in positioning the coastline using both the tide-coordinated and non-tide-coordinated imagery. It is anticipated that this work will assist NGS in generating accuracy metadata for photogrammetrically-mapped shoreline, as well as in project planning and decision making. An important characteristic of the TPU model developed in this work is that it is general enough to be extended to other coastal regions and settings.

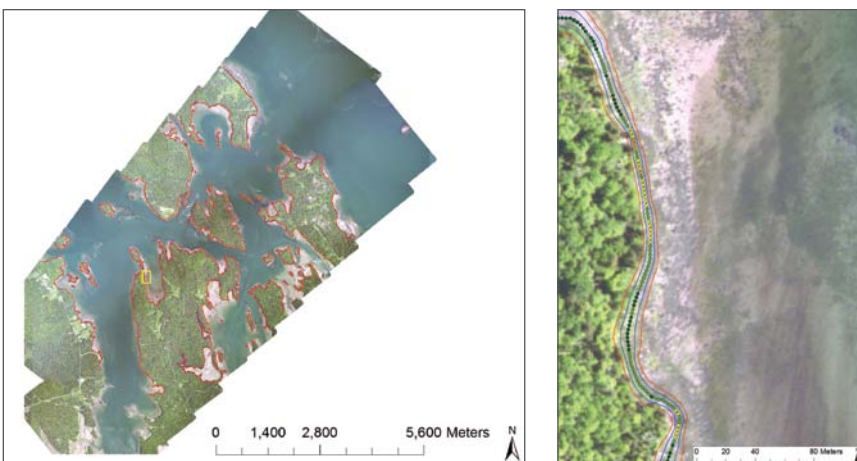

Figure 4-13. Uncertainty boundaries. The blue lines and the red lines represent the standard uncertainty and the uncertainty at the 95% confidence level respectively. The black lines are the MHW shoreline. (Left) the imagery for the whole study area. (Right) the enlarged imagery for the yellow box in the left imagery; the point colors represent the slope in degree.

## Shoreline Change After Hurricane Sandy

*For information—funded by another NOAA grant*

As part of the Center's effort to support post-Hurricane Sandy relief activities, Lindsay McKenna, working with Chris Parrish, Brian Calder and others, has developed a work flow for establishing pre- and post-storm shoreline and erosion maps along the New Jersey coast using EAARL-B topo-bathy lidar collected by the U.S. Geological Survey (USGS). The processing work flow uses open source software to merge raw 'las' files, Fledermaus to grid the data, and ArcGIS to extract the shoreline and create erosion maps. Shorelines referenced to the MHW datum, from both pre- and post-storm EAARL-B data for an area on Long Beach Island, NJ, are shown in Figure 4-14 along with an erosion and deposition map for Barnegat Bay derived from subtracting pre- and post-storm bathymetric lidar grids data. The derived shorelines were also compared to the USGS 2000 MHW shoreline (Figure 4-14).

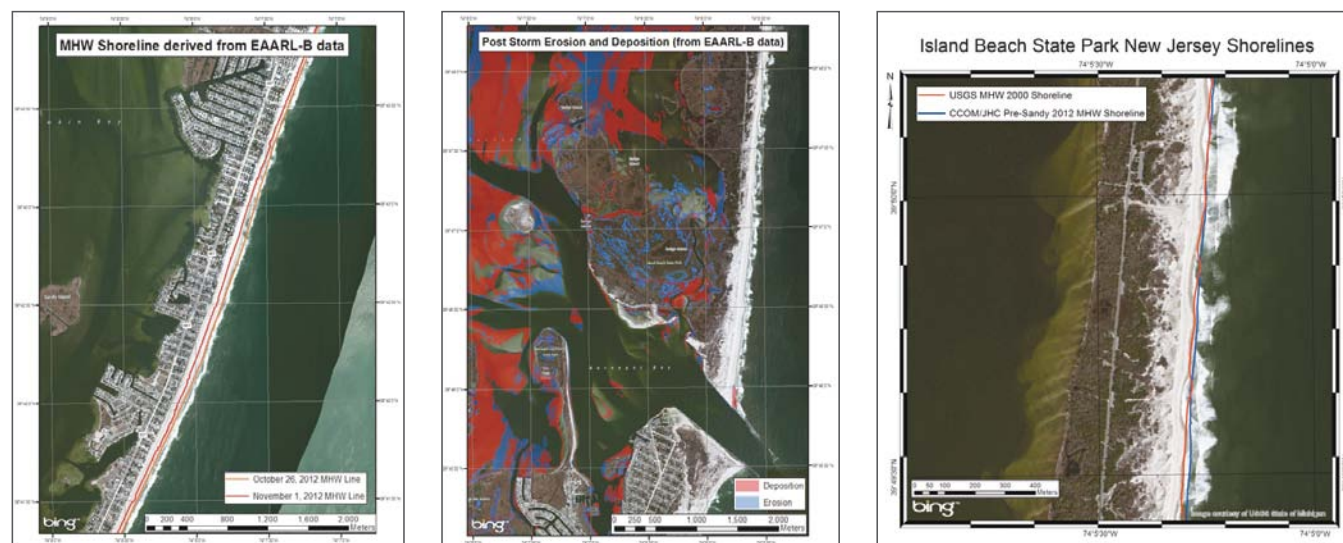

Figure 4-14. Pre- and post-Hurricane Sandy shoreline (referenced to MHW) along 5 km of Long Beach Island, NJ (left). Areas of erosion and deposition in Barnegat Bay caused by Hurricane Sandy (middle). Comparison of shorelines—red is the USGS 2000 MHW shoreline; blue is the shoreline calculated from EAARL-B lidar collected before Sandy impacted the coast (right).



## Bathymetry from Imagery

The ability to derive bathymetry from satellite imagery is of increasing interest to a number of government agencies and private sector firms due, in part, to the reported capabilities of a number of new algorithms and satellite sensors. For example, Landsat 8, WorldView-2, and the planned WorldView-3 have all been reported to provide enhanced capabilities for coastal bathymetric mapping. A Center team, headed by Shachak Pe'eri, has been developing and evaluating approaches to extracting bathymetry from satellite imagery (Satellite Derived Bathymetry—SDB) as well as exploring the applicability of SDB for change analysis, benthic habitat mapping, depth retrieval in remote regions, and hydrographic survey planning (Pe'eri et al., 2013). In the first stage of this research effort, the potential use of Landsat satellite imagery to map and portray shallow-water bathymetry was investigated at three study sites: U.S., Nigeria, and Belize. Publicly-available, multi-spectral satellite imagery and published algorithms were used to derive estimates of the bathymetry in shallow waters. The study determined the most appropriate algorithms based on their performance using different frequency band combinations and spatial filters. Also, the accuracy of the results was modeled using a Monte-Carlo simulation and validated empirically using a reference dataset. Based on the success of this first stage, the procedure is now being documented and will be published in a GEBCO “cook-book” for the use of hydrographic offices world-wide.

In 2013, these techniques were applied to two regions where bathymetric data is sparse (Haiti and offshore of the North Slope of Alaska) in order to better understand their viability as tools for producing useful hydro-

graphic data. As part of the humanitarian aid effort in response to the Haiti Earthquake disaster, NOAA and other hydrographic offices around the world provided support to SHOH (Service Hydrographique et Océanographique de Haiti) by training SHOH personnel, surveying key areas around Haiti and updating the charts. As part of the 2013 NOAA effort to support SHOH, the satellite-derived bathymetry approach was used to evaluate shallow waters in areas that were not surveyed after the earthquake. Commercial multispectral satellite imagery (Landsat 8 and Worldview 2) was used to derive bathymetry (Figure 4-15). This work was done in collaboration with NOAA's Marine Charting division (MCD) and NGA.

The Satellite Derived Bathymetry (SDB) procedure has proven itself as a useful reconnaissance tool in tropical and sub-tropical waters, especially over sandy seafloors. However, the question arose as to whether it can be useful in regions where high levels of sediment input produce low water clarity (such as Arctic coastal areas). Also, the sources of turbidity are not uniform along the coast line and may affect the calculations. As a result, the SDB procedure was further developed to compile multiple satellite images and using only the areas that were identified “clear” by comparison (i.e., minimum water clarity change between two satellite images). This work was done in collaboration with NOAA's MCD (Figure 4-16). This effort is now being evaluated as a potential procedure to be used by NOAA's Hydrographic Survey Division (HSD) over the eastern Aleutian Islands (Bechevin Bay, AK).

As a component of this analysis, Chris Parrish developed a total propagated uncertainty (TPU) model for satellite-derived bathymetry grids. The first phase of

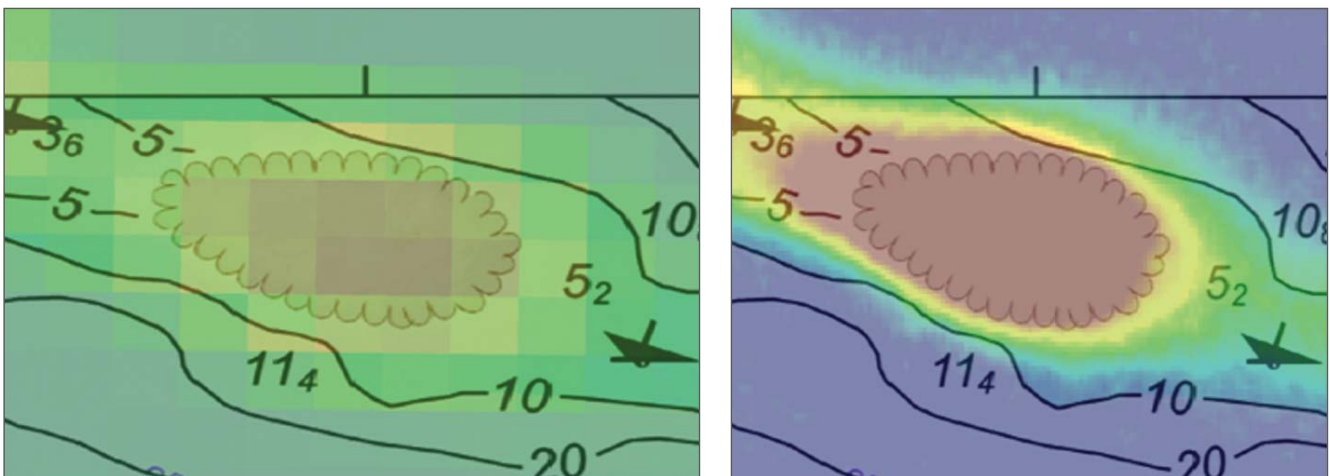

Figure 4-15. Bathymetry derived from Landsat 8 imagery (left) and WV-2 imagery (right) over a shoal in Port-au-Prince, Haiti.

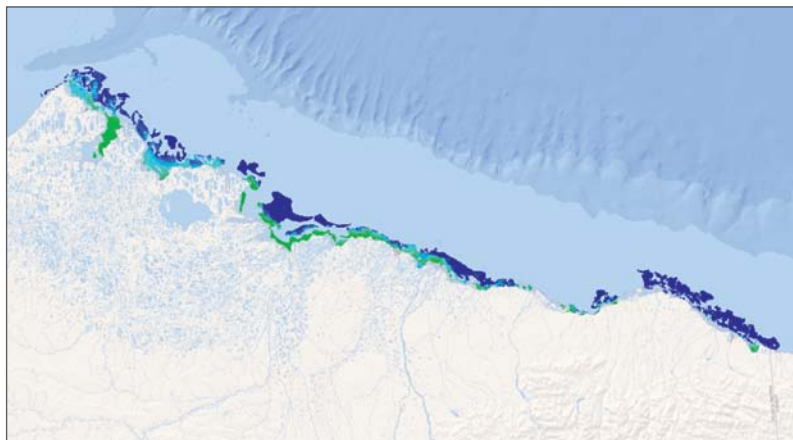

Figure 4-16. Shallow-water bathymetry derived offshore of the North Slope of Alaska using Landsat 7 (1999-2003) and Landsat 8 (2013) imagery.

this work, completed in 2012, involved developing a Monte Carlo algorithm for propagating uncertainties in input images and reference data to uncertainties in final satellite-derived bathymetry data sets. Recent progress included using the model to better understand how uncertainty in satellite-derived bathymetry varies from one project site to another, as well as how it varies spatially throughout an individual project site as a function of depth and other variables. For example, the model was used to assess the range of depths in which the project team's algorithm for estimating bathymetry from satellite imagery would perform best. For our Massachusetts and Belize test sites, this range was found to be 2-3 meters. In deeper areas, the uncertainty increases approximately linearly with depth, up to the extinction depth, at which point bathymetry estimation is no longer possible. Interestingly, uncertainty also increases in the shallowest areas (< 2 m), which may be attributable to wave effects and long-shore currents, which lead to difficulties in bathymetry estimation. The most recent enhancements to JHC's TPU model for satellite derived bathymetry include the ability to output uncertainty surfaces, which enable visual analysis of uncertainty throughout a project site (Figure 4-17).

## Improved Backscatter Processing

In parallel with our efforts to improve bathymetry processing techniques, several processing efforts are aimed at improving our ability to extract high quality, and hopefully quantitative, backscatter data from our sonar systems that can be used for seafloor characterization, habitat and many other applications. Although these efforts are discussed under the PROCESSING theme, it is clear that they are closely related to our HABITAT and IOCM themes.

## Uncertainty of Backscatter Measurements—NEWBEX

As the use of backscatter data becomes more common (and particularly as we begin to use backscatter for seafloor characterization), we must face the same questions we have asked about bathymetric data and now need to understand the uncertainty associated with backscatter measurements. Most simply put, when we see a difference occur in the backscatter displayed in a sonar mosaic, does this difference truly represent a change in seafloor characteristics or can it be the result of changes in instrument behavior or the ocean environment? Mashkooor Malik is completing a Ph.D. aimed at

addressing the very difficult question of identifying and quantifying the uncertainty sources of multibeam echosounder (MBES) backscatter surveys. An evaluation of MBES backscatter uncertainty is essential for quantitative analysis of backscatter data and should improve backscatter data collection and processing methodologies. Sources of error are being examined both theoretically and empirically. The empirical component requires that the effect of each uncertainty source be isolated and observed independently. These efforts began in 2008 as part of Malik's thesis (see the 2008 Progress Report for the full description of these experiments and the update below), but have seen renewed focus prompted by the visits of Xavier Lurton in 2012 and 2013 and a lab-wide decision to refocus on backscatter issues in the light of the needs of NOAA's IOCM program (see below).

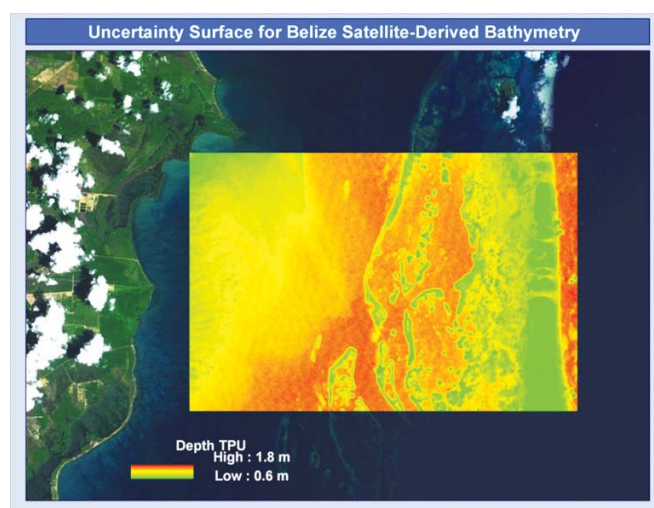

Figure 4-17. The output of the satellite-derived bathymetry TPU model for a portion of the Belize Barrier Reef north of Big Creek was gridded to produce this relative uncertainty surface.

This effort has manifested itself in the “New Castle Backscatter Experiment” (NEWBEX) a new (or renewed, from the laboratory perspective) effort aimed at testing our ability to properly collect and interpret seafloor backscatter data collected with hydrographic multi-beam echosounders. The project is a collaboration of many Center and NOAA participants including Tom Weber, Jonathan Beaudoin, Glen Rice (NOAA), Briana Welton (NOAA), Val Schmidt, Brian Calder, Yuri Rzhonov, Larry Mayer, Larry Ward, and Carlo Lanzoni.

It is important to note that the term “calibrated” takes on multiple meanings in the context of this work, ranging from the calibration of settings to ensure we understand the real effect of a system setting change to a full absolute calibration where the output of the multibeam echosounder can be used as estimates of the true seafloor scattering strength. This project brings together several different existing lab efforts: Malik’s thesis work, Carlo Lanzoni’s work toward an absolute backscatter calibration for MBES, former student and

NOAA Corps officer Sam Greenaway and Glen Rice’s efforts toward field procedures for proper backscatter data collection, backscatter mosaicing (Fonseca’s GeoCoder), backscatter inversion (Fonseca’s ARA algorithms), and backscatter ground truth (e.g., optical imagery, bottom sampling, high accuracy positioning).

Many of the details of the NEWBEX experiment were presented in the 2012 Progress Report. The field program has continued and as we come to the end of 2013, we are nearing the end of a very intense and successful eight-month long field campaign. The short-term objective of the field campaign is to establish a standard backscatter line conveniently located near the UNH pier in New Castle, NH with known seafloor backscatter (at 200 kHz), where ‘known’ equates to an empirically derived absolute seabed backscattering cross section with an associated uncertainty. This data is being collected with a calibrated split-beam echosounder at a launch angle of 45° on a weekly basis. The standard line (Line Segment A in Figure 4-18a), which

was chosen in consultation with NOAA OCS in anticipation of the arrival of the *Ferdinand Hassler*, begins in a gravel area on the north end, traverses a large sand wave field, and ends in an area of clean gravel (see inset seabed images in Figure 4-18a, top row). At regularly spaced intervals along the line, the data have been averaged (the number of samples averaged is typically equal to or greater than 200) to provide an estimate of the mean backscatter level.

Remarkably, the variability in the mean backscatter level over an initial ten-week period of the study is small, with a total spread that is typically less than 2 dB (Figure 4-18b). We will be analyzing the backscatter trends over the entire timeframe, and will also attempt to observe any changes resulting from large storm events, including a storm event that took place at the end of December.

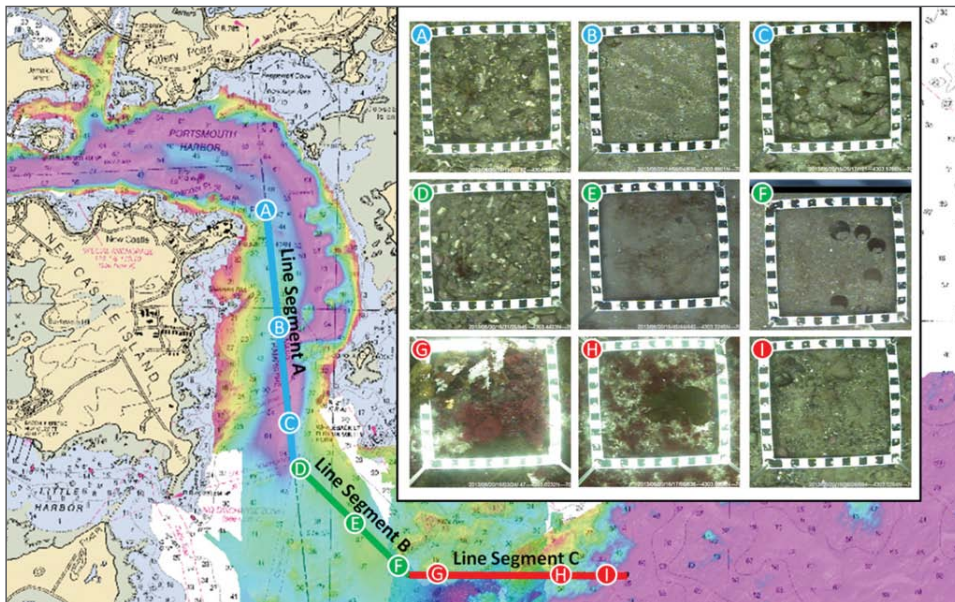

Figure 4-18a. The NEWBEX standard line and field campaign locations. Images from a subset of groundtruth sites are shown.

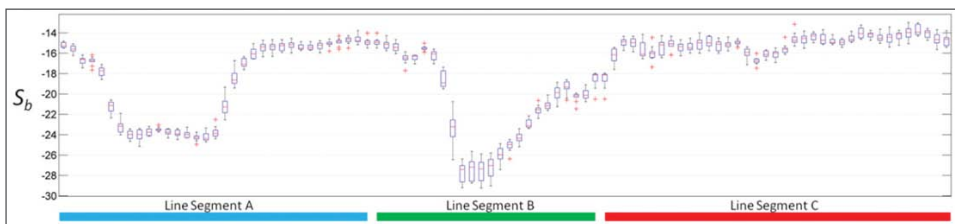

Figure 4-18b. A boxplot describing the distribution of average seabed backscatter,  $S_b$ , collected weekly over ten weeks. The boxes describe the boundaries of the 25<sup>th</sup> and 75<sup>th</sup> percentiles, the central mark is the median, and the whiskers extend to the most extreme data points not considered to be outliers.



In addition to the standard line, the field campaign has added two line segments (B and C in Figure 4-18) that traverse over other bottom types including an area of what appears to be fine sand (middle of line segment B) and an algae covered bedrock area (much of segment C). Two sites (one in the sand wave field and one in the middle of line segment B) are being sampled every week with a small grab sample, and we have twice sampled 15 stations along the line with both a drop camera and a Shipek grab sample. Together, these data represent a unique opportunity to examine the temporal variability of oblique incidence backscatter and relate changes (both spatially and temporally) to knowledge of grain size and substrate type.

The NEWBEX field campaign has the luxury of using a calibrated split-beam echosounder, the purpose of which is to enable us to collect absolutely calibrated acoustic backscatter. We still continue our attempts to provide effective calibration methods for multibeam echosounders. To this end, John Heaton (CCOM graduate student) has been working on a “synthetic” extended target constructed of small chain links to mimic the random scattering from the seafloor. The intent is to generate a fast tank calibration procedure. If this is successful, we may consider options to extend this to the field. Heaton presented initial results from his tank experiments at the Acoustical Society Meeting this past June in Montreal.

All of these efforts support the end goal of helping NOAA OCS and other organizations appropriately understand (from an acoustics perspective) backscatter collected with multibeam sonars. The results of the NEWBEX field work and the tank calibrations are ultimately intended to result in a set of standardized field procedures and data analysis methodologies. This is beginning to be realized in the work of Briana Welton (graduate student and NOAA Corps officer—see SENSORS section), in the collaboration of Jonathan Beaudoin with QPS, and in the planned participation of Glen Rice (NOAA contractor and UNH Ph.D. student) in an international assemblage of experts attempting to write a best practices multibeam backscatter document.

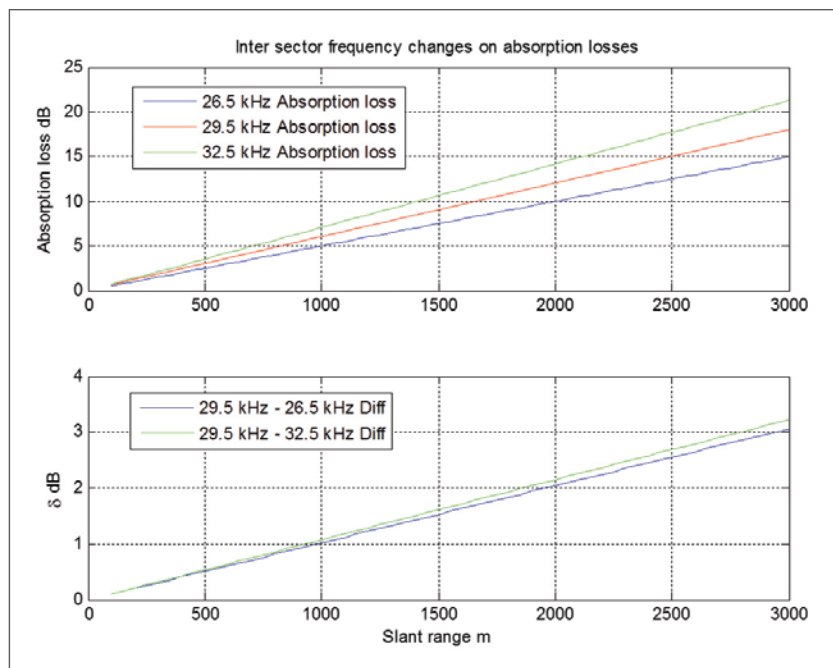

Figure 4-19. Absorption losses expected for various frequencies employed in different transmit sectors in the case of an EM 302. Note the differences in the absorption loss (one way) can be as much as 1-2 dB at 1000 m range for the maximum differences in the frequency sectors (26.5 kHz vs. 32.5 kHz). Lower panel shows the realistic bias obtained during backscatter measurements while using the absorption loss for nominal frequency of 29.5 kHz.

The NEWBEX experiment has built upon Mashkor Malik’s thesis work attempting to identify and quantify the uncertainty sources associated with MBES backscatter survey. Malik’s project has been reported upon in detail in earlier progress reports but, in 2013, Malik benefited from an extended visit to IFREMER to work with Xavier Lurton on aspects of this problem. As a result of this visit, Malik has produced an analytical treatment of the sonar equation with the purpose of deriving backscatter uncertainty equations. This treatment is summed up in Table 4-1.

Malik is now looking in more detail at the impact on uncertainty of many of these components. For example, the transmission loss is affected by the uncertainty in the absorption coefficient which is, in turn, affected by the use of a nominal frequency (instead of the specific frequency in each transmit sector). This effect is system-dependent and depends on the specific implementation of the computation of the absorption coefficient. Estimates of uncertainty that would be introduced in the transmission loss based on the use of nominal frequency in the case of an EM 302 are presented below (Figure 4-19). Similar analyses are being done on other components.

Uncertainty in	Depends on:	Sub-components	First order magnitude
Transmission Loss	Beam steering angle	Ship attitude	Ignored (effect included in error of range to seafloor)
		Sound speed	System dependent
	Range to seafloor	Sound speed Measured propagation time	Up to 2 % of transmission loss
	Absorption coefficient	Model Frequency Temperature Salinity Pressure Bubbles Micro thermal structure	Up to 5 % System dependent Ignored Ignored Need better model Ignored
	Spreading Loss form / shape	SVP	< 0.1 dB- Ignored
Seafloor incidence angle	Beam steering angle	Sound speed at sonar head Ship attitude	Ignored Ignored
	Refraction	SVP	Up to 12° in extreme cases
Seafloor incidence angle Area <u>ensonified</u>	Seafloor slope	Across/along track slope	< 10 deg for 10 deg slopes
	Refraction	Bathymetry errors	Depends on the smoothing and quality of DTM
	Seafloor slope Beam width	Signal footprint scale Seafloor roughness	System dependent Seafloor type dependent
		Frequency Ship attitude	<i>To be developed</i>
Area <u>ensonified</u>	Pulse length	Average sound speed	<i>To be developed</i>
		Effective pulse duration definition	
	Seafloor incidence angle		<i>To be developed</i>
Sonar response	Receive sensitivity	Stave sensitivity	Ignored
		Amplifier gain (electronics temperature)	
	TVG	Saturation, noise floor, Nonlinearity (deviation from the model-imperfect electronics)	Ignored- no effect if TVG is properly accounted for
	Rx Beam Patterns	Intrinsic static directivity	<i>To be developed</i>
		Ship motion	
	Pulse length	Ramping up	System dependent
	Spectrum mismatch	Doppler	<i>To be developed</i>
	Source level	Age, Biofouling, settings, element failure, temperature	Typically less than 1 dB
		Electric power input (electronics temperature)	Ignored
		Nonlinear gains	
	Tx Beam Patterns	Intrinsic static directivity	<i>To be developed</i>
		Ship motion	
	Signal to Noise Ratio		Ignored if better than 10 dB
	Other components	Inherent variability of seafloor backscatter	Azimuth dependence Speckle Vegetation Short-term time fluctuations- current ripples+storm Bio-turbation Heterogeneity...

Table 4-1. Components and subcomponents of the sources of uncertainty in the seafloor backscatter measurement using a multibeam sonar.

## Restructured GeoCoder

With the departure, several years ago, of Luciano Fonseca, the developer of our backscatter processing software, GeoCoder, the Center needed to re-evaluate its approach towards backscatter processing and sea-floor characterization. Research efforts have resumed in full force at the Center this year through collaboration with industrial partner IVS3D (now QPS). In this revitalizing effort, IVS3D has restructured their implementation of GeoCoder and developed a new internal architecture that allows Center researchers (and others) to access data in the backscatter processing path and replace, improve, and add key modules through a plug-in interface. This removes the software engineering overhead from Center researchers and allows us to focus on much smaller scope problems for which we have expertise. It is important to note that in taking this approach, the algorithms and software modules developed by Center researchers will be available to all Center industrial partners. The hope is that this approach will provide a flexible and extensible R&D tool that will enable us to carry on in the field of seabed characterization research.

This year, Jonathan Beaudoin and QPS's Moe Doucet have continued to expand and flesh out the Fledermaus GeoCoder Toolbox (FMGT) "plug-in" architecture. This partnership allows Center researchers to take advantage of QPS's efforts to retool the original GeoCoder software framework into a robust, stable and modular software tool. The key to this partnership is the retooling of the GeoCoder processing pipelines into software modules; these modules honor the algorithms implemented in the original GeoCoder framework but with clear boundaries being set between the various data flows and processing stages such that researchers can investigate and potentially improve upon a single module without the overhead of maintaining the overall software framework or rebuilding (compiling) the entire application.

Doucet and Beaudoin's efforts have focused on better understanding the code from not only a developer's point of view but also a researcher's point of view. An initial visit in November of 2012 started the process with much of the redundant and undocumented code being removed and the remaining code being consolidated into sets of library modules. A second meeting in June 2013 led to the migration of the majority of the CCOM IP into the Geocoder library modules with the QPS plug-in technology only presenting a thin interface between the library and the host application, FMGT. The ultimate aim is to develop a standalone library that

can be used internally at CCOM with a user interface of our own choosing or construction, and be distributed, with or without the source code, to other Industrial Partners for use in their own implementations of the original Geocoder. Beaudoin and Doucet have been iterating towards a phased development approach in which the original Geocoder functionality is re-implemented in phases. At this stage, it is anticipated that the first version of the library will:

- Translate standard file formats (e.g., .all and .gsf) into internal Geocoder structures;
- Perform geometric and radiometric corrections as necessary;
- Provide corrected seafloor backscatter measurements in a suitable output format for further analysis if desired;
- Perform line based filtering, e.g., AVG and beam patterns;
- Assemble seafloor imagery into a slant-range corrected ground trace in a suitable format for mosaicing by third party software.

The current vision is to focus on re-implementing the geometric and radiometric corrections for current Kongsberg, Reson and R2Sonic MBES in the new Geocoder library. Future stages of work will focus on re-implementing the mosaicing engine and seafloor characterization algorithms such as ARA, with these potentially being developed as separate libraries

## Backscatter Working Group

The interest in establishing efficient and optimal workflows for generating high-quality backscatter data has gone far beyond NOAA. At the international Geohab 2013 Conference (a conference that focuses on techniques for mapping habitat), a Backscatter Working Group was formed to define a set of best practices and guidelines for backscatter acquisition and processing using multibeam echosounders. Many members of the Center are represented on this working group—Jonathan Beaudoin, Brian Calder, Mashkooor Malik, Larry Mayer, Glen Rice, Val Schmidt, Tom Weber, and Briana Welton. Glen Rice was selected to represent the Center on the chairing group and will coordinate the backscatter acquisition chapter of the planned document. Work on this document is ongoing, with a final draft planned for the Geohab conference in 2014.



## Marine Target Detection and Object Recognition (MaTaDOR)

As we continue to improve the quality and resolution of the bathymetry and backscatter data we collect, the ability to detect small objects on the seafloor is enhanced. While the military has faced this challenge for many years, the hydrographic community has become acutely aware of the need to detect and identify small objects on the seafloor in the wake of the devastation caused by events like Hurricane Sandy. Much of the coastal infrastructure destroyed by the storm was carried offshore, creating hazards to navigation and grave threats to the health of the ecosystem. We have thus embarked on a new effort, to develop tools for the detection and identification of submerged marine debris. Expanding on work started during his master's thesis, Giuseppe Masetti, who has now returned to the Center as a Post-Doctoral Scholar, will work on this task under the supervision of Brian Calder. In the coming year, these efforts will evolve into a Hurricane Sandy-specific project funded by separate NOAA funds.

Typically, submerged marine debris has been identified through the subjective evaluation of sidescan sonar records by a human operator. Masetti's project explores the use of automated approaches to identification and classification of submerged marine debris, using the techniques developed for the detection of mines, unexploded ordinance and pipelines with the significant difference of a much wider range of potential targets. In order to address this additional complexity, an adaptive algorithm is being developed that appropriately responds to changes in the environment, context, and human skills. The main steps of the process are outlined in Figure 4-20.

Many algorithms have poor performance in practice since the conditions present in test scenarios are often not representative of the conditions used to develop and train the algorithm, violating a fundamental assumption of traditional pattern recognition. Gathering a robust test set that fully explores all parts of the potential object set that will be encountered in the field

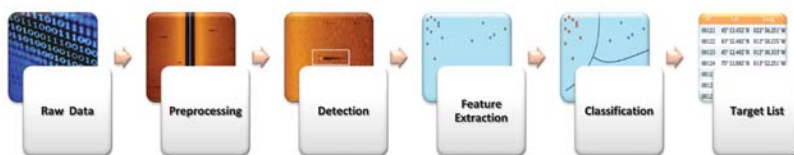

Figure 4-20. Main steps followed by the developing target recognition algorithms. Raw data are properly corrected before the application of one (or more) detection and feature extraction technique. The output of the final classification step is represented by a list of possible targets

is, however, extremely difficult and often time-consuming. The solution, therefore, is in the development of algorithms that can respond appropriately to changes in the environment, detection context, and the skills of human operators. In other words, the algorithms need to attempt to adapt to the new underlying test-data distributions in case they are not sufficiently well represented in the training data.

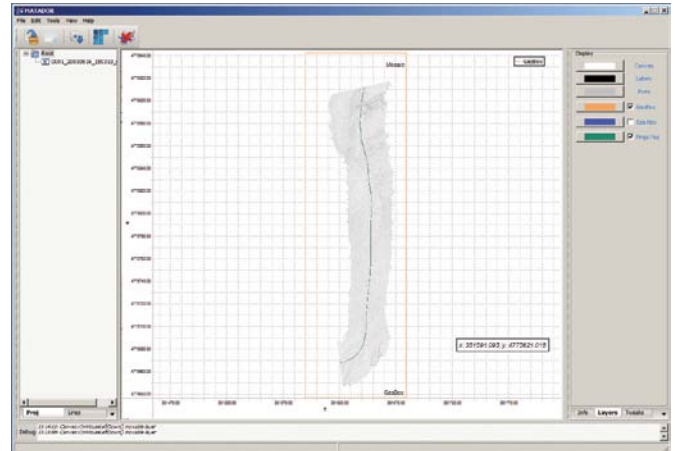

Figure 4-21. Screenshot of Matador's developing GUI showing the output of the mosaic engine applied to acoustic data collected in Great Bay, NH by a Kongsberg EM 3002 MBES.

Before analysis of sonar data, the data must be properly corrected both geometrically and radiometrically. As described earlier in the DATA PROCESSING section, years of effort at the Center have been focused on developing these corrections. After the application of these corrections, the approach being developed manages the fusion of a set of statistical- and physical-based algorithms, working at different levels (swath, beam, snippet, and pixel) and using both predictive modeling and a phenomenological approach.

Identification of individual targets is an important aspect of tackling the marine debris problem, but working on individual targets is only part of the problem. To be effective, the techniques developed must be able to handle aggregations of targets, enabling the analysis of spatial distributions, meta-analysis, and inventory.

The research will enable the construction of a marine debris inventory through the use of a spatial relational database. The attribute fields will be defined from a survey of possible useful and commonly available information. Having the results of object detection and filtering activities available as a spatial database will allow us to consider the feasibility of a relevant marine site risk index for marine debris prioritization, developing some of the ideas of a previous project

focused on potentially polluting marine sites (PPMS). The output of the tool will be a marine debris list stored in a geodatabase with information organized using ISO Geographic Markup Language schemas, ready to be used in web GIS (using ERMA and GeoPlatform implementations) and environmental databases (e.g., NOAA RULET/RUST) through a process of automatic translation. The code is currently in early stages of testing (Figure 4-21).

## Data Management

After five years of searching for an appropriate data manager for the Center, we are delighted to report that, in 2011, we filled the position with the very capable Paul Johnson who comes to us from the University of Hawaii's Mapping Research Group. Paul has made tremendous progress in ensuring that our data holdings are protected, documented, organized and easily accessible to our researchers and to any others who need them. Working with Johnson, Tianhang Hou has been focusing on creating appropriate metadata and areal coverage polygons for two our largest databases—the eight seasons of Arctic multibeam sonar data collection (see LAW OF THE SEA theme), as well as 12 years of hydrographic field camp surveys). Hou has also been working with Johnson in developing automated ways of bringing our multibeam data into the ArcGeodatabase.

## ArcGIS Data Server

During the spring of 2013, the Center transitioned from a Linux-based ArcGIS server to a Windows Server 2008R2-based system. This process was partially driven by the availability of a high quality server machine which had become underutilized following the migration of the Center's data stores from its older SAN units to new storage systems (see IT Section). The change to a Windows-based machine for the Center's GIS server has led to simpler system administration, and given the Center much better processing and serving speed due to the improved hardware.

Once the new server was in place, Johnson began moving the existing web mapping services away from a model that relied on ESRI's web mapping services to being directly served through a combination of the Center's webserver and the GIS server. This changeover

allowed for the implementation of many needed improvements to the web-based dynamic maps. Figure 4-22 shows a comparison of a previous generation web map and a new locally hosted map.

Improvements include a widget-driven interface where users are able to interact with the data; "brand" the web maps to identify the Center as the source of the data; select which base maps, including custom sources, are made available for users to overlay the Center's data on; to customize the interface to best suit the mode of presentation (embedded, full screen, mobile, etc.); and the ability to now serve the Arctic Law of the Sea data in a proper polar projection with a basemap (see <http://ccom.unh.edu/theme/law-sea/arctic-ocean> and discussion in LAW OF THE SEA section).

The improvements to the interface continued during the fall of 2013, where Johnson began to work on switching the dynamic web maps to the new interface style being developed for the Great Bay Estuary and Gulf of Maine datasets (see discussion below). This migration should be complete by early spring 2014 and is designed to integrate the bathymetry and backscatter into a single dynamic web map for each site. This new style will also give the user the ability to toggle between datasets and adjust the transparency of the datasets on the fly.

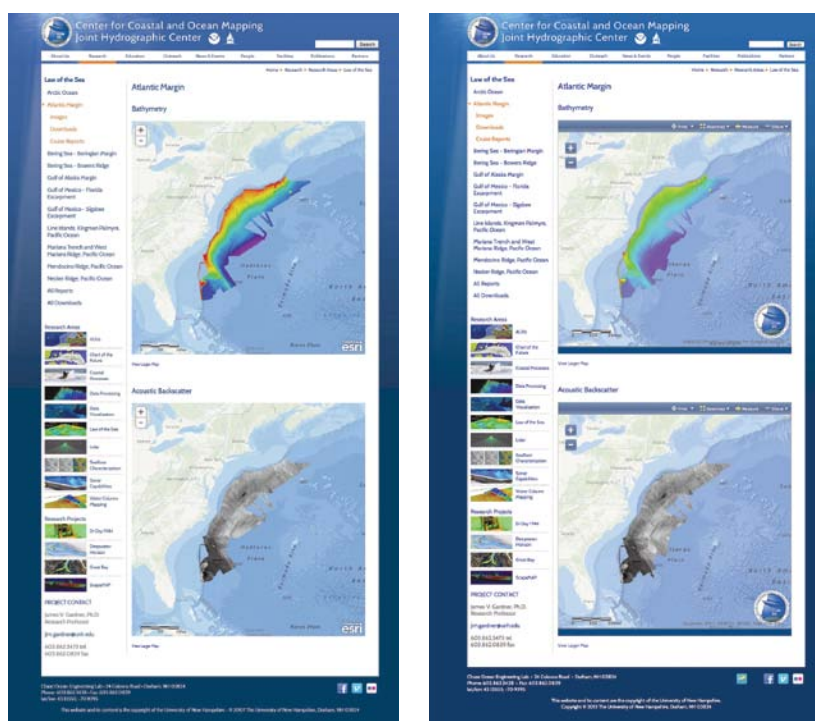

Figure 4-22. Comparison of web maps generated by ESRI mapping services (*left*) and those generated locally (*right*). Local delivery provides much greater speed, interactivity, branding, and customization.

## Organization, Visualization, and Distribution of Bathymetry and Backscatter Data from Portsmouth Harbor, Great Bay Estuary, and the Gulf Of Maine

Many of the field activities of the Center are focused on the local waters of Portsmouth Harbor, Great Bay, and the Gulf of Maine resulting in the collection of many years of data from the region and numerous requests for these data. Fourteen years of collecting these data have resulted in multiple data sets, in various forms, scattered throughout our storage systems. This has made it challenging at times when faculty, students, staff, or people from outside the Center have sought to determine what data is available for different areas and what the quality of that particular dataset is. In order to streamline this process and make it easier for both the users and for the data manager, Johnson began organizing these datasets into geodatabases, which were in turn linked to a GIS project and mapping services.

An initial start was made on this effort during the spring of 2013 when Johnson identified any data and documentation available for these areas on the Center's data storage devices. Where documentation was lacking, Johnson queried the center's personnel for any information that they might have, in order to generate as much metadata as possible for each dataset. The identified and documented datasets were then made available locally to the Center's personnel through two different paths. Currently, the first path is through an ESRI ArcMap project (.mxd file) hosted on an openly shared resource available to all users in the lab. This project links to all available coverage maps, bathymetry grids, and backscatter grids loaded into geodatabases hosted by the Center's GIS server (Figure 4-23).

This GIS project has greatly aided and sped up the process of determining the availability of data for different areas, identifying that data, and then making maps. In 2013, the project was used many times including supplying maps to users doing a lobster breeding grounds project around the Isle of Shoals, providing researchers bathymetry and backscatter data for geologic interpretation of structures within the Gulf of Maine, generating maps for users planning a cable

for a wave buoy off the Isle of Shoals, and aiding the Center's Summer Hydro students during their survey planning.

The data have also been made available through a currently under-development web interface. At present, Paul has loaded outlines and grids for all summer hydro programs into the web mapping interface (Figure 4-24). Users may interrogate the individual layers to determine surveys for the area they are interested in. They may then open up the data in a web-based GIS interface ([com.unh.edu/gis/summerhydro\\_2012\\_gis.html](http://com.unh.edu/gis/summerhydro_2012_gis.html)) where they can query location, measure areas, create PDF maps, and save views. Work on this project continued through the fall with the continued development of the GIS server back end, the integration of more data into the geodatabases, the generation of syntheses of data with common color pallets and shaded relief, and, finally, the optimization of the JavaScript responsible for generation of the dynamic maps.

## A Hydrographic Universal Data Description Language (HUDDL)

A fundamental operation in any data processing environment is the management of the binary file formats in which data is supplied, processed and archived. Changes to these formats are not always well documented, however, and writing the format library to read and write data is tedious and error prone. Previous work by Brian Calder has resulted in a simple data format compiler which translates an ASCII description of typical hydrographic data formats into C-code to read

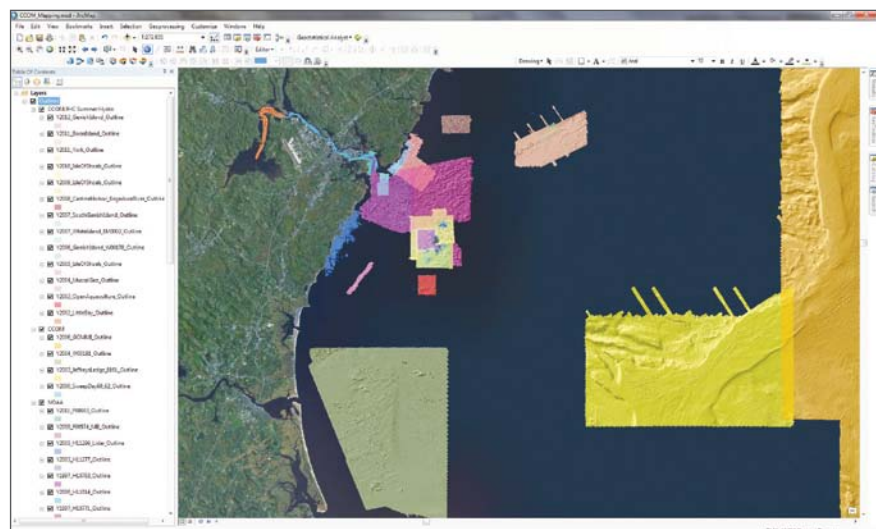

Figure 4-23. ESRI ArcMap Project depicting JHC data holdings in the vicinity of Portsmouth, NH.



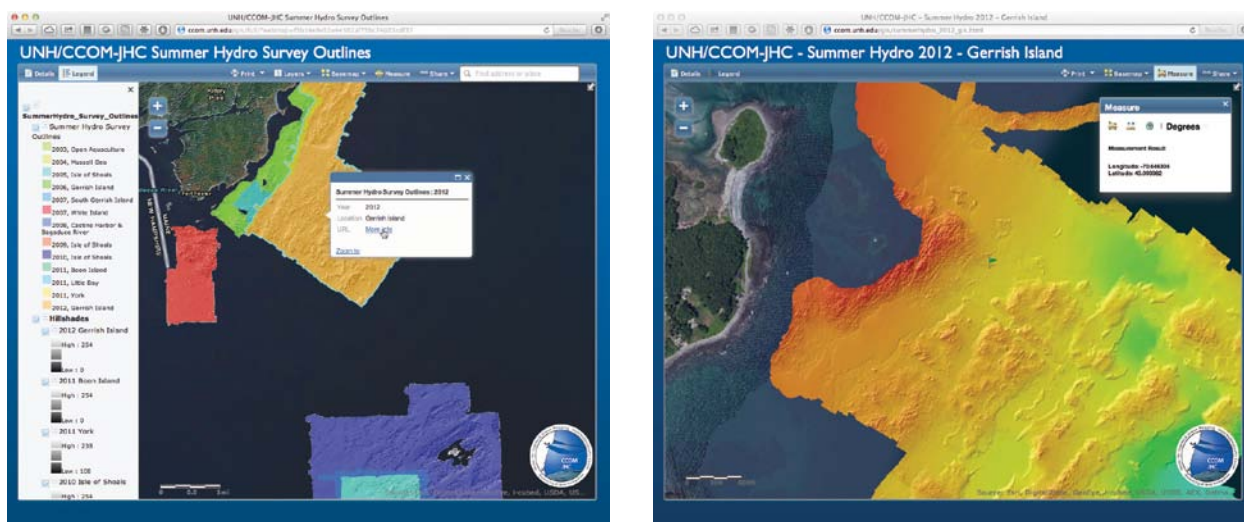

Figure 4-24. Newly developed web interface for serving local JHC data bases (left). Extraction of data set from web-based data-base into web-based GIS tool for data queries (right).

the data, but this code is aging, and does not take advantage of newer description languages, such as XML, which allow for more expressive description of data structures with better error checking, better distribution mechanisms and improved visibility.

Giuseppi Masetti and Calder have therefore started a project to upgrade and significantly extend the previous methods, using XML schemas to describe core and extended data objects in the sorts of binary data files used in hydrographic practice (a Hydrographic Universal Data Description Language—HUDDL). The ultimate goal is to convince hardware manufacturers to provide schemas that describe their data formats, and provide a repository of those schemas to which users and software vendors could refer when faced with a new data format. The core architecture includes schemas to describe the data formats, a compiler to generate I/O libraries from them, XSL stylesheets to translate the descriptions into human-readable documentation for the file format, and a demonstration repository for the schemas with push updates for changes (Figure 4-25). The project design also includes a multi-language back-end so that native code can be constructed in a number of different languages, taking advantage of the features in that language to improve the API or performance of the code. The initial target implementation will be C++, with MATLAB and Python being added if the project proves successful.

Another aspect of HUDDL is that it provides a powerful tool for data archiving centers that store data in their native formats, rather than converting them to a standard format. Since the creation of an XML schema

describing a data format requires minimal effort in terms of time and computer science knowledge, legacy datasets will acquire a renewed accessibility, and scientists will be able to efficiently and easily retrieve data. In addition, the creation of a unique Web repository for the HUDDL descriptive schemas can provide a safe and easy-to-check common point to look for data format specifications, and widely used systems (e.g., RSS, an open-subscription mailing list) can for rapid updates. Thus, HUDDL represents a solution for both software and hardware manufacturers, providing a strong and universal mechanism for version control of hydrographic data formats.

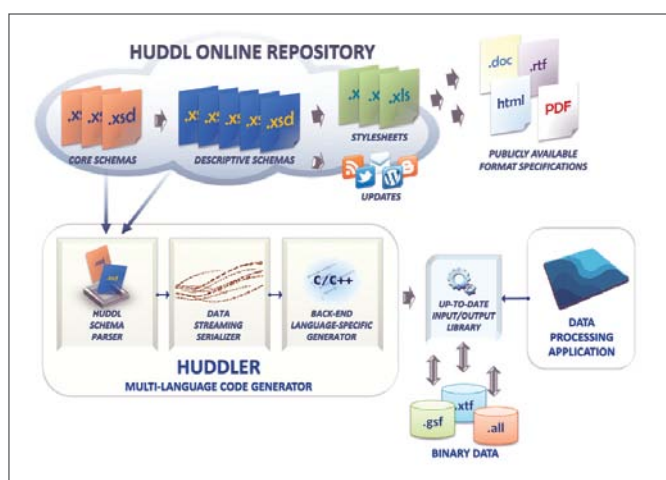

Figure 4-25. HUDDL framework: the online repository is used both for providing format specifications (in different formats) and as source for code generators. Data processing applications can thus rely on this library to access the binary data.

## Theme 3 – Habitat and Water Column Mapping

### Developing Tools and Approaches for the Adaptation of Hydrographic, Coastal and Ocean Mapping Technologies for the Mapping of Benthic Habitat and Exploring the Broad Potential of Mapping Features in the Water Column

The initial focus of early multibeam echosounder development was the collection of dense, high-resolution bathymetry in support of chart-making and other aspects of safe navigation. With the evolution of sonar development came the simultaneous collection of backscatter (amplitude) information, initially from the seafloor and, most recently, from both the seafloor and the water column. This backscatter information offers a wealth of additional information beyond the depth data initially provided by the time-of-flight measurements of the multibeam echosounder. The Center has long pursued research focused on trying to better understand and calibrate the backscatter measurements provided by the various sonar systems available (see Backscatter section of PROCESSING theme). Understanding the nature of the backscatter produced by the sonar systems is an essential component of any seafloor characterization research. In parallel with these efforts, we are also developing approaches to apply backscatter measurements to problems of benthic habitat determination and the mapping of water column targets. All of these applications also have direct relevance to our IOCM Theme.

#### Habitat Mapping

While habitat mapping is a desired end product of many seafloor mapping efforts, just what habitat mapping means is not well defined. Our response to this question is to focus on developing approaches for characterizing the seafloor through the analysis of data we can derive from the sensors with which we work (sonars, lidar, satellite imagery and hyperspectral scanners). As we perfect these techniques (which are currently far from perfect), we work closely with biologists and fisheries scientists to see how the data we provide can be used to answer the critical questions they face. From a seafloor perspective, the key parameter that offers the best chance for quantitative characterization of the seafloor is acoustic backscatter. If sonar backscatter data are to be used to correctly characterize seafloor properties, however, the measured backscatter must represent changes in the seafloor rather than instrumental or environmental changes. Although many system and geometric corrections are applied by the manufacturers in their data collection process, some corrections are not applied (e.g., local slope), and for others, many questions remain about how and where the corrections are applied. As described under the SENSORS theme and in the Backscatter Processing section of the DATA PROCESSING theme, we have been working closely with NOAA and the manufacturers to fully and quantitatively understand the nature of the backscatter data collected and to develop tools (e.g., GeoCoder) that can properly make the needed

adjustments to the data. At the core of this effort is the NEWBEX experiment (described previously). Once such corrections are made, the resulting backscatter values should be much more representative of true seafloor variability and thus provide an important component of efforts to remotely characterize the seafloor.

#### Multibeam Mapping to Support Habitat-Based Groundfish Assessment and Deep-water Coral Research in the Gulf of Alaska

As part of our IOCM activities (see IOCM theme), we are also exploring means of extracting multiple datasets from a single sonar survey/system. To this end, Jodi Pirtle and Tom Weber are collaborating with the NOAA Alaska Fisheries Science Center (AFSC) to map groundfish habitat in the Gulf of Alaska (GOA) using the Simrad ME70 fisheries multibeam echosounder (ME70) with the primary goal of distinguishing between trawlable and untrawlable areas of the seafloor using multibeam acoustics. This information will ultimately improve efforts to determine habitat-specific groundfish biomass and to identify regions likely to contain deep-water coral and sponge communities that may be considered Habitat Areas of Particular Concern (HAPCs). This research supports NOAA's efforts to identify and describe Essential Fish Habitat (EFH) for harvested species, and to improve fisheries stock assessment methods for locations and seafloor types that are not easily

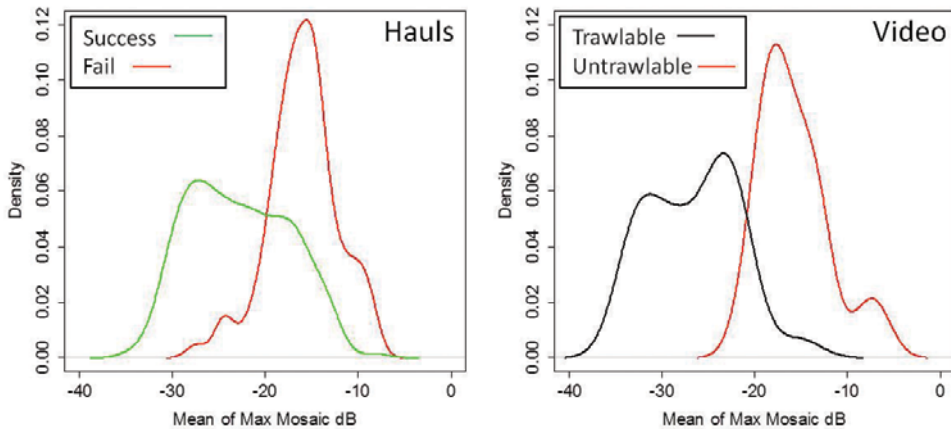

Figure 5-1. Histograms describing the distribution of seafloor backscatter strength ( $S_s$ ) (mosaic values normalized to oblique incidence angles of 30-50°) at locations in the GOA previously sampled (1996-2011) by the AFSC bottom trawl survey and classified by performance as successful (success) or marginally successful and failed due to gear damage (fail) (left) (right).

accessible. The ME70 installed on the NOAA Ship *Oscar Dyson* was originally designed for mapping pelagic fish schools but, in the spirit of IOCM, the ME70 is now routinely being used for seabed mapping purposes, using software developed over the last few years at the Center (in collaboration with NOAA Fisheries).

The 2012 progress report detailed the analysis of ME70 data collected in 2011 and 2012 by the AFSC during their GOA-wide biennial acoustic-trawl survey for walleye pollock from the *Oscar Dyson*. During these surveys, the ME70 was opportunistically used for bathymetric mapping and to collect absolute seafloor scattering strength. Pirtle participated in two of the three cruises, during June and August 2011; Pirtle and Weber provided support remotely from the Center during the winter 2012 surveys. In this study, ME70 data were matched to the spatial location of previously conducted AFSC bottom trawl survey hauls from 1996-2011 to discriminate between trawlable and untrawlable seafloor types in the region of overlap between the trawl path and ME70 data. Hauls had been previously classified as successful, marginally successful, or unsuccessful (failed) by AFSC researchers based on the level of gear damage sustained from contact with the seafloor. The ME70 survey data corresponded with the location of 582 hauls, including 487 successful hauls and 95 marginal or failed hauls. From this work, Pirtle and Weber were able to demonstrate that the angle-dependent seafloor backscatter strength ( $S_s$ ) from the ME70 data was significantly higher in untrawlable seafloor than areas with trawlable seafloor. The three haul performance categories show separation in  $S_s$  across incidence angles, with successful haul locations having

lower values overall, corresponding to finer grain size, or the lack of strong scatterers such as boulders and rock on the seafloor. Likewise, areas of trawlable seafloor at camera stations generally have lower  $S_s$  values across the range of incidence angles sampled by the ME70.

Retaining and analyzing the full angular dependence of the backscatter is complex and not commonly done, so Pirtle and Weber have also evaluated the use of the commonly generated backscatter mosaics as a tool for discriminating trawlable vs. untrawlable habitats and demonstrated that the distribution of backscatter strength

from the normalized mosaic values were also able to separate trawlable from non-trawlable seafloors (Figure 5-1).

Other backscatter and bathymetric metrics have also been extracted and combined in a general linearized model (GLM) to provide a best estimate of trawlability from ME70 derived products (e.g., oblique incidence backscatter, bathymetric position index, seafloor roughness). The percent deviance explained for the best model is approximately 60%. A draft manuscript is currently being prepared by Pirtle.

### Seafloor Characterization and Habitat Studies—Jeffreys Ledge and Little Bay Estuary

Jeffreys Ledge, a major morphologic feature in the Gulf of Maine, is extremely important to regional bottom fisheries (a large portion of Jeffreys Ledge is inside the Western Gulf of Maine Closure Area). Knowledge of the seafloor characteristics and controlling geologic processes are important for evaluating bottom habitats on Jeffreys Ledge, which in turn are important to fisheries management. In addition, insights into the morphology and sedimentology of Jeffreys Ledge are important to the overall understanding of the evolution and geology of the Gulf of Maine. Previously (2002-2005), a significant field campaign by a multidisciplinary group was conducted at Jeffreys Ledge including high-resolution bathymetry, extensive bottom sampling for sediment and benthic in fauna analysis, and videography for assessment of bottom type and benthic epifauna. A significant portion of this work was presented in a



master's thesis and two scientific journals (Malik 2005, Malik and Mayer 2007, and Grizzle et al. 2009). As a result of these studies, a rich database including high resolution bathymetry, sediment grain size, videography, and subbottom seismics exists for Jeffreys Ledge. In the past year, a significant effort was invested in continuing the analysis of the Jeffreys Ledge data including a review and upgrade of the sediment sample database (~125 locations) and re-analysis of bottom video from ~150 stations for seafloor characteristics and grain size classification. During this reporting period, bottom images were extracted from the video from each station to enhance the seafloor coverage. From this effort, an archive of nearly 700 images was developed to directly accompany the seafloor classifications and descriptions from the sediment and video. This database, now complete, provides a clearer understanding of the seafloor characteristics of the study area and associated habitats and provides an excellent test bed for future habitat studies.

We have also focused on exploring techniques for collecting habitat data in the very shallow waters of Little Bay Estuary, NH. For these efforts, Tom Lippmann and graduate student Joshua Humberston have been using a dual frequency (24 and 200 kHz) single beam echosounder mounted on either the CBASS (see SENSORS section) or a small survey launch. A comparison between sediment samples and the echo-sounder bathymetry and backscatter intensities allowed a first-order evaluation of the distribution of mud fraction in the Little Bay Estuary. Particle size distribution was characterized by the fraction of silts and clays (muds) of the surficial sediments and ranged from 1-75% silt/clay, indicating regions of predominantly mud or sand, and areas with a mixture of the two. The bathymetry data show a reasonably strong (logarithmic) relationship with mud fraction with increasing mud content as the depths shallow (with skill of 0.44). This is not surprising considering that the strong currents down the center portion of the deep channel tend to winnow out the fine particles and deposit them on shallower mud flats that border the Bay. Comparisons between sediment mud fraction and the 24 kHz intensities do not show any appreciable correlation, most likely a result of volume scattering effects of the lower frequency acoustic pulses, but the 200 kHz signal—with much lower volume scattering—correlates more closely with the sediment type, particularly for the maximum and total intensity return from the bottom (Figure 5-2). In this case, there is a logarithmic relationship between mud fraction and maximum backscatter intensity (with skills of 0.25 and 0.54, respectively).

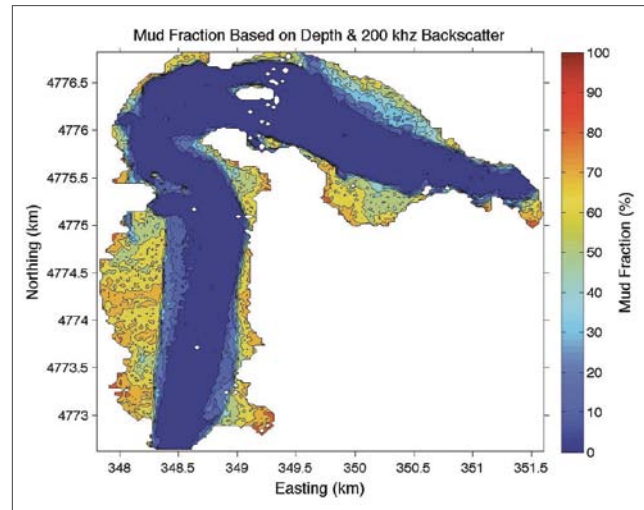

Figure 5-2. Distribution of mud fraction based on an average logarithmic model that includes depth,  $I_{tot}$ , and  $I_{max}$  and all sediment samples of the Bay. These data provide a gross, first order approximation of the mud fraction in the surficial sediment of the Bay.

## Lidar, Hyperspectral and Optical Approaches to Habitat Characterization

In addition to using sonar backscatter for the characterization of the seafloor, we are also looking at the potential of using lidar, hyperspectral and optical imagery to derive critical seafloor and habitat information.

### Benthic Habitat Mapping from Lidar

Remotely-sensed data sets that can be used to generate benthic habitat maps and other products are becoming increasingly available for a number of environmentally-sensitive coastal areas around the U.S. The source data can include lidar bathymetry, lidar-derived seafloor reflectance (or pseudo-reflectance), and aerial imagery, in addition to acoustic data, such as MBES and calibrated backscatter. These data are of great interest to a number of NOAA program offices and their partners, but there are several challenges that currently inhibit their wide-scale use in generating the required products, including:

- Demand for the products currently exceeds resources and capabilities needed to generate them.
- Downstream users typically lack specialized software and training to be able to generate end products.
- Existing procedures are specific to certain sensors or sensor types.

- Lidar return amplitudes have not been fully radiometrically-calibrated.
- Products often contain a number of artifacts.

To address these challenges, Center researchers have initiated a research project in collaboration with Steve Rohmann of the NOAA Office of National Marine Sanctuaries (ONMS) to develop tools and workflows that will enable wide-scale use of remotely-sensed data for producing the required habitat-relevant products without the need for expensive, specialized software, training, or additional resources. The primary goal of this work is to build upon existing benthic habitat mapping procedures developed by the NOAA National Centers for Coastal Ocean Science (NCCOS) and overcome the challenges listed above. In particular, we seek to develop and test standardized, sensor-independent (e.g., LADS, SHOALS, CZMIL, EAARL-B, VQ-820-G, Chiroptera) processing procedures, based on open-source and/or low-cost COTS software, for producing benthic habitat maps to support conservation and management of marine ecosystems and associated organisms. The procedures must be designed to work with readily-available data and must not assume access to data types that would not typically be provided (e.g., raw lidar waveforms or interim downstream products). Another key goal is ensuring that the products generated from these procedures are consistent with existing benthic habitat maps developed by NCCOS and others so that change analysis can be performed.

Working with Steve Rohmann and under the supervision of Chris Parrish, Shachak Pe’eri, and Jenn Dijkstra, graduate student Xiao Guo is currently conducting a project to address these challenges. The project focuses on a ~1600 km<sup>2</sup> site in the Marquesas Keys, a chain of mangrove islands in the National Wildlife Refuge ~40 km west of Key West, Florida. The available data for this site include SHOALS lidar bathymetry, lidar-derived relative reflectance imagery (uncalibrated), aerial multispectral imagery, and ground truth data consisting

of underwater video imagery and seafloor reflectance spectra obtained by divers. The goals of the project are to develop methods of further correcting the lidar relative reflectance products and to combine them with the other available data sets to generate benthic habitat maps, following a NOAA CCMA hierarchical habitat classification scheme. To facilitate use of the procedures by the coastal management community, a primary objective is to ensure that they can be implemented in readily-available GIS software without specialized tools or training.

Progress to date on this project has included developing and documenting a new method for classification of geographic zones based on lidar relative reflectance, lidar-derived bathymetry, seafloor slope and rugosity, and Landsat 7 imagery. Additionally, the project team has demonstrated the ability to remove seamline artifacts from lidar relative reflectance data through processing applied in the Fourier domain using commercially-available image processing software (Figure 5-3).

## Lidar Waveforms for Salt Marsh Mapping

To further evaluate the potential use of lidar for habitat mapping we also are exploring the behavior of the returned lidar waveform as an indicator of substrate type. Recent lidar research conducted at the Center has focused on generating and testing shape-based lidar waveform features that are proving to have a number of important uses. These features include statistical moments, integrals, and other computationally-simple

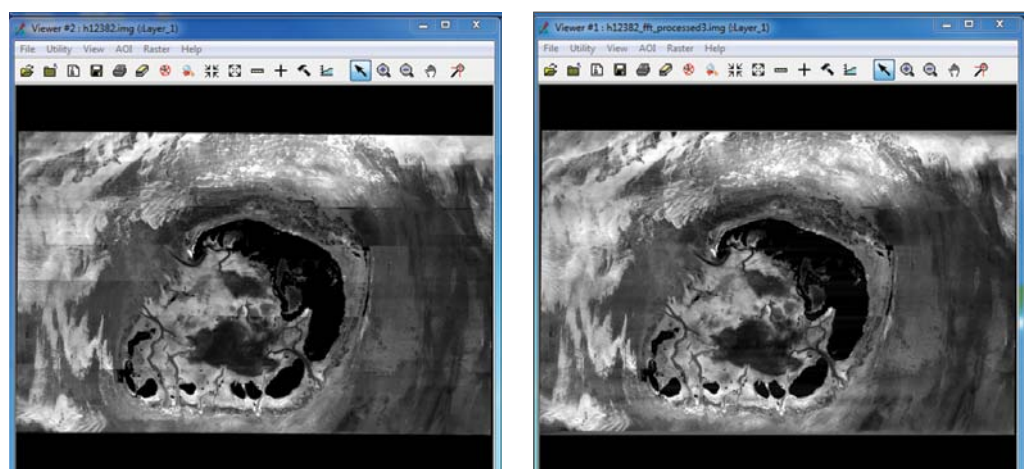

Figure 5-3. Results of the procedure to remove seamline artifacts in lidar relative reflectance data to facilitate coral reef habitat mapping. *Left*: input to Fourier-domain seamline removal procedure; *right*: output. It can be seen in the output image that many of the seamlines between adjacent flightlines (oriented east-west in the original image) have been greatly reduced or even eliminated.

metrics. Because many characteristics of the coastal zone (e.g., presence, species, and height of vegetation; substrate type; etc.) influence the size and shape of return lidar waveforms (Figure 5-4), analysis of these waveform features may enable estimation of biogeophysical parameters that are of interest to the coastal management community and other users of NOAA coastal lidar data. Additionally, it is anticipated that this work will enable users of coastal geospatial data to derive the benefits of full-waveform lidar, without requiring access to the actual waveforms, which are often either unavailable or treated as proprietary information by data providers.

A project team, including Chris Parrish, Jeff Rogers (a current NRESS Ph.D. student), Brian Calder, and Larry Ward, first demonstrated the ability to use waveform features in assessing vertical uncertainty variation in lidar-derived digital elevation models (DEMs) of coastal salt marshes (Parrish et al., 2013). An important finding of this work is that simple estimates of return pulse width alone were able to explain nearly 60% of vertical uncertainty variation in three salt marshes on Cape Cod, Massachusetts. This variation in elevation uncertainty throughout a marsh is important to scientists and managers, since elevation differences of just a few centimeters can affect marsh migration and loss in response to sea level rise. An example of a relative uncertainty surface computed from waveform features

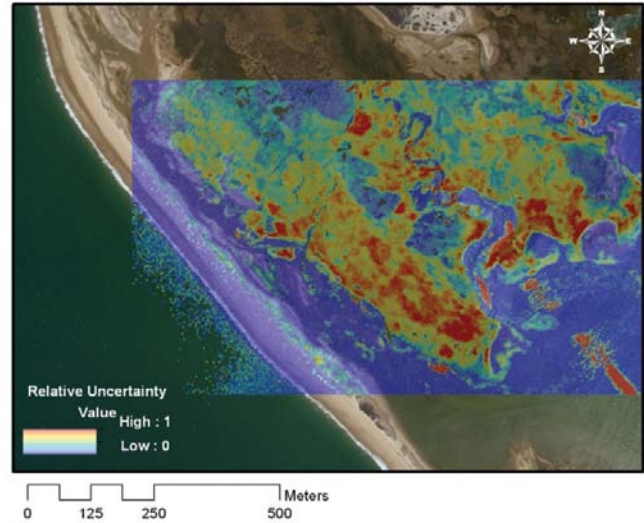

Figure 5-5. Relative uncertainty surface (arbitrary scale of 0-1 relative uncertainty units) for Moors marsh on Cape Cod, MA. If these types of surfaces can be provided as a standard output of future NOAA lidar projects, they may enable coastal managers to better understand the relative quality of elevation information across a marsh and assist in decision-making.

for a portion of Moors marsh on Cape Cod is shown in Figure 5-5. A current phase of this work, which is being led by Rogers as part of his dissertation research, involves using these waveform features to predict salt marsh vegetation biophysical parameters (Rogers et al., 2013).

Recently, Parrish worked with NOAA colleagues, Lt. Russell Quintero and Stephen White, and the American Society for Photogrammetry and Remote Sensing (ASPRS) on enhancements to ASPRS's LAS file format to support topographic-bathymetric (topo-bathy) lidar. These enhancements will enable JHC lidar research to benefit the broader lidar user community by providing simple mechanisms to store and retrieve information extracted from return waveforms in coastal lidar data.

## Habitat Mapping and Change Analysis in Sandy-Impact Area

*(For information—funding through another NOAA grant)*

Ongoing research at the Center is enabling topo-bathy lidar data collected by NOAA and partner agencies in the region impacted by Hurricane Sandy to serve the needs of many users, including coastal zone managers. A Center research team, including Chris Parrish, Jenn Dijkstra, and Lindsay McKenna, is investigating the use of NOAA topo-bathy lidar data to assess eelgrass

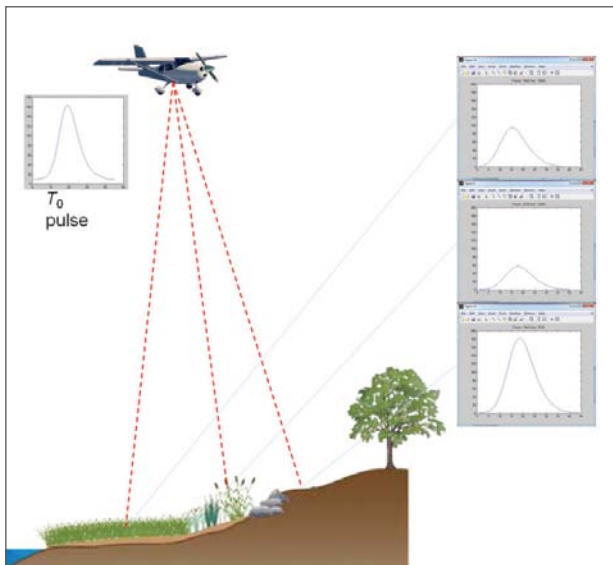

Figure 5-4. Analysis of return waveform shapes may enable prediction of biogeophysical parameters of interest to coastal managers and other users of NOAA coastal lidar data (Parrish et al., 2013; Rogers et al., 2013). The graph in the top left is a typical transmit ( $T_0$ ) lidar pulse, while, on the right, are examples of return waveforms from different locations within a salt marsh.



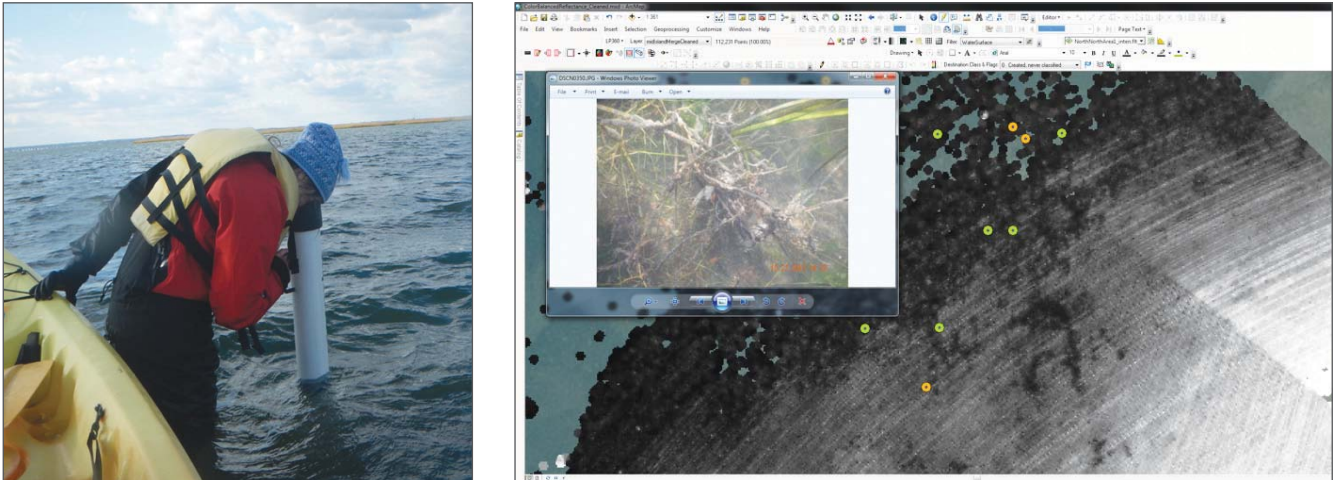

Figure 5-6. *Left*: Collecting reference data for shallow-water benthic habitats. *Right*: Interactive map in ArcGIS showing gridded reflectance values and the locations of pictures collected in the field with a hyperlink to the image.

habitat change resulting from Hurricane Sandy. In the initial phase of this work, the team is investigating the ability to map benthic habitats in Barnegat Bay, a shallow estuary located along the New Jersey coast that was heavily impacted by the storm, experiencing two meters of storm surge, as well as barrier island breach and overwash.

This work makes use of lidar point attributes that are now available in point clouds produced by NGS using the new Riegl VQ-820-G from data collected in Barnegat Bay in June and September 2013. In the procedure developed by the JHC research team, these point attributes are gridded, radiometrically balanced, and then used as input to an object-based image analysis procedure to generate benthic habitat maps. To assess the classification accuracy of these habitat maps, the project team acquired ground truth in the vicinity of Barnegat Inlet in October 2013. The reference data included underwater imagery and GPS positions for a number of shallow-water habitats (Figure 5-6).

Preliminary results of comparisons against the field-surveyed reference data indicate that four habitat types can be readily distinguished in the new data layers generated from the topo-bathy lidar: sand, mixed sand and macroalgae, sparse eelgrass, and dense eelgrass (Figure 5-7). Future work will include extending these procedures to USGS EAARL-B topo-bathy lidar data collected both immediately before and after Sandy made landfall. By comparing the pre- and post-Sandy benthic habitat maps, the project team hopes to be able to identify areas in which eelgrass habitat was lost as a result of the storm.

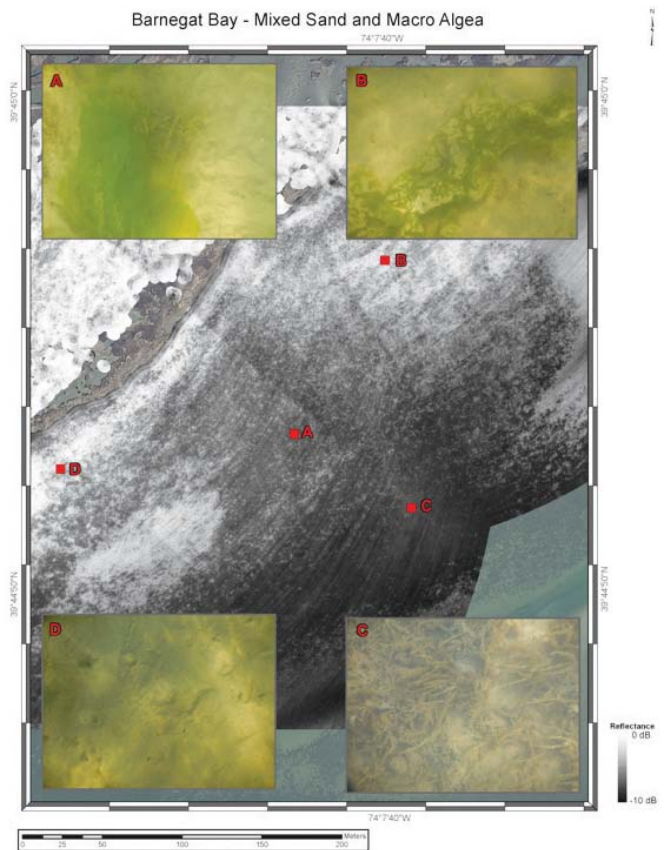

Figure 5-7. Gridded reflectance values in Barnegat Bay, NJ with ground truth pictures. Sand (picture B) has the highest reflectance values, while thin vegetation (picture A and D) have medium reflectance values, and dense vegetation (picture C) have the lowest reflectance values.

### Instruments to Ground Truth Sonar, ALB, Hyperspectral, and Other Remotely Sensed Data

As we strive to better understand the ability of our sonar or lidar systems to provide quantitative information about the seafloor and water column, we inevitably must ground-truth the remote measurements we make. To ensure that we can accurately determine the properties of the seafloor upon, and water column within which we are making our measurements, we have developed a suite of tools and approaches.

#### Optical Collection Suite (OCS and BUGS)

In order to better understand the environmental factors that influence optical remote sensing data and extend ground truth capabilities for NOAA platforms, the Center has been developing several ground-truthing sensor suites. The Optical Collection Suite (OCS) is a ground-truthing system that enables researchers to collect underwater imagery with real-time feedback, while measuring the spectral response and quantifying the clarity of the water with simple and relatively inexpensive instruments that can be hand-deployed from a small vessel (see details in earlier progress reports). The OCS system has been operational since 2009 and has been used in several ground-truth missions that supported airborne lidar bathymetry (ALB), hyperspectral imagery (HSI), and swath-sonar bathymetric surveys in the Gulf of Maine, southwest Alaska and the U.S. Virgin Islands. Based on the success of the OCS, an autonomous system, the Benthic Underwater Ground-truthing System (BUGS) was designed for deployment from AUVs or ROVs.

In contrast to the OCS, BUGS is designed for underwater operations without top-end monitoring. The current design is self-contained and can be added to an AUV as an additional section or towed independently from surface platform. The two key sensors in BUGS are a spectrometer (for collection of upwelling radiation) and a camera (providing texture of the seafloor). LED panels in the system are used to provide controlled down welling irradiation. In addition, the system includes a computer for data storage, auxiliary sensors (e.g., attitude, pressure, and temperature), and a Wi-Fi network that allow the system to connect to a computer and transfer data without the need to open the system.

In 2013, the prototype BUGS system was tested in a controlled environment, where data streaming from all the sensors was synchronized. Discussions with NOAA's CSDL indicated that the mostly likely platform for deployment of BUGS would be on their REMUS AUV with typical mission lengths of six to eight hours. Accordingly, hardware development efforts have focused on increased autonomy (currently it can only operate for

two hours), increased robustness, and enhanced optics (the current version uses an off-the-shelf "fish eye" lens with 160-degree field-of-view that caused barrel distortion. This has been replaced with a 40-degree field-of-view lens that did not have such a radial distortion). In addition, the data storage capability of the system has been increased from one to four hours.

#### Reconstruction of Original Color in Images of Underwater Scenes

In order to ground-truth the acoustic, lidar and other remotely sensed data we collect, we often use optical (photo or video) data. Color carries much useful information in underwater imagery—from health of vegetation to identification of debris, but often, due to wavelength-dependent absorption of light by water, the color of objects will vary depending on light source (ambient, artificial), water clarity (dissolved matter, suspended particles), range from camera to imaged scene, and properties of the camera sensor (quantum efficiency, QE). This can greatly degrade the value of the imagery to provide ground-truth data. To address this issue, Yuri Rzhannov has been working collaboratively with Shachak Pe'eri and others to develop techniques to reconstruct original color in underwater images. To obtain "true" color measurement (or at least a consistently biased measurement), all of the above factors must be quantified and compensated.

We have explored several approaches. First, a device was designed and built to calibrate an arbitrary camera (some manufacturers provide QE curves for their sensors, but most do not). Broad-spectrum white light passing through a calibrated monochromator is input into a black-painted box (to minimize reflections and effects of stray light) and an image of the transmitted or reflected light is taken by the camera. The spectral components of the light source are also measured and a QE curve is calculated for the camera. Alternatively we have proposed a technique that requires only a waterproof MacBeth color chart and several images of it taken underwater at known distances by a camera with known QE curves.



Figure 5-8. Knowledge of 24 true colors and their appearance in the image allows for solution of coefficients for 3D warping (in RGB space). Original image of sea floor sediment sample (left) and image with warped colors based on knowledge of MacBeth color table.

The primary difficulty in determination of water absorption coefficient  $C_k(\lambda)$  from photographic images is that the coefficient is a nonlinear wavelength-dependent function that is integrated over all the visible spectrum. Our approach consists of splitting the range of wavelengths into a number of intervals (not necessarily equal) and to assume that  $C_k(\lambda)$  is constant within each interval. Thus, the nonlinear function becomes an unknown constant and can be found by solution of a system of linear equations. Depending on the number of different colored squares in the image and number of intervals, the system may have a unique solution, or be over-determined and solved in a least squares sense. The estimates of absorption coefficient for spectrum intervals are inaccurate (especially in the case of a small number of squares), but it is known that, for certain types of water, the function of absorption coefficient on wavelength can be described by one of the so-called Jerlov curves. Fitting calculated coefficients to members of the family of Jerlov curves gives information about clarity of the particular water sample and the complete function of  $C_k(\lambda)$ . A laboratory (in air) version of this phenomenological approach is shown in Figure 5-8.

### Reconstruction of 3-D Underwater Scenes

A constraint on the use of underwater imagery is the limited field of view afforded by most optical systems. To address this issue, Yuri RzhanoV has developed a number of techniques for the automatic mosaicking of underwater imagery (see previous progress reports). In 2013, his efforts on image rectification focused on the reconstruction of three-dimensional scenes, a particularly challenging problem for imagery not collected to photogrammetric standards. As neither color nor

brightness constancy holds for underwater imagery, the only reliable cue for 3-D reconstruction is a texture, which by definition has spatial extent and changes its spatial frequencies depending on the direction of view. RzhanoV, working with graduate student Han Hu, has developed an algorithm for quasi-dense close-range Euclidean reconstruction motivated by ideas developed for photogrammetric applications. The process starts with a region-growing approach using a limited number of reliable point matches. All matches are ranked according to their trustworthiness (reliability). New matches that satisfy constraints are searched for in the immediate vicinity of previously accepted matches with highest ranking. Points in different views are assumed to match if the normalized cross-correlation score for patches (under some affine transform) around these points is sufficiently high. An optimal affine transformation (which is sometimes called weakly perspective, because it captures slight perspective deformations too) is found iteratively. If iterations do not converge quickly, the matching is considered to fail. A local smoothness constraint requires coefficients of the found affine transform to be close to that of the accepted neighbor. If the difference between coefficients exceeds a predefined threshold, the current patch is likely to include a discontinuity, so the growth in this direction is stopped. After every acceptance of matches, they are re-sorted again, so that region growing continues from the current most reliable match. Due to the nature of affine matching, the conjugate point can be found with subpixel accuracy. Quasi-dense matches are triangulated for construction of a point cloud. Overlap between three consecutive images (typically not exceeding ten percent of the image area) is sufficient for calculation of a trifocal tensor. The point triples are



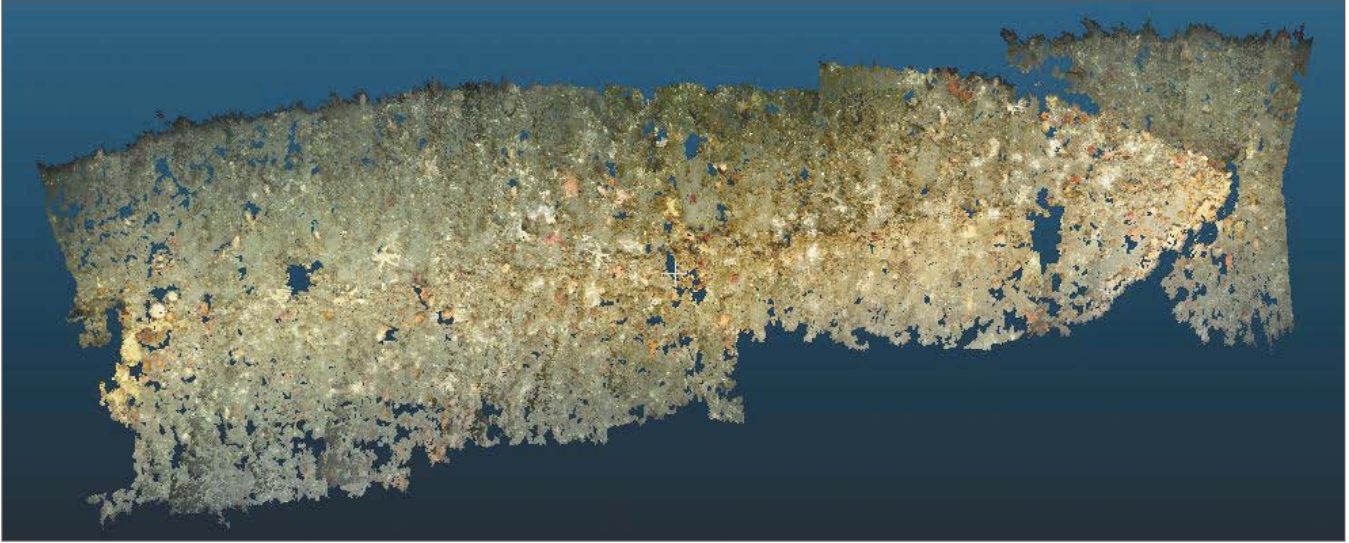

Figure 5-9. Reconstruction of 3-D point cloud containing around 10,000,000 points.

subjected to bundle adjustment which defines a ratio of two sequential baselines. The final step is a bundle adjustment applied to all matched points (each belonging to two of three sequential views) that corrects for errors accumulated in the cascading process described above. However, without path “closings” the final shape will be imperfect even after the bundle adjustment. The algorithm has been applied to a set of still images of a WWII seaplane found in Canadian waters. Data obtained from Thierry Boyer, Underwater Archaeologist AgenceParcs Canada/Parks Canada Agency (Figure 5-9).

### Sedimentology Lab

The interaction of both sound and light with the seafloor is often dependent on the nature of the seafloor and, in particular, the distribution of grain size in the sediment. In 2013, the Center contributed to the upgrade of the Sedimentology Lab at the UNH Jackson Lab so that we would have assured access to sediment analysis facilities. The laboratory, which is now fully functional and available for all Center projects, utilizes standard sieve and pipette techniques to determine grain size. We also have access, through a collaborative agreement with the Department of Earth Sciences, to a Malvern Mastersizer Hydro 2000-G Laser Particle Size Analyzer. During this reporting period, grain size analyses for over 50 sediment samples collected as part of the NEWBEX project were conducted as well as analyses for other projects. In the course of these efforts, several students were trained in using these analytical techniques.

### Water Column Mapping

While fisheries sonars have imaged the water column for some time, this capability is new to multibeam sonars. Combining the ability to image the water column and the seafloor over wide swaths with high-resolution offers great opportunities for new applications and increased survey efficiencies. The Center has been very active in developing tools to capture, analyze and visualize water-column data and these tools proved extremely valuable in our efforts to map the deep oil plume and monitor the integrity of the Macondo well-head during 2010’s Deepwater Horizon crisis (see the 2010 annual report for a full description of our activities related to Deepwater Horizon). Our demonstration of the viability of using sonar systems for mapping natural gas seeps and leaking well-heads in the Gulf of Mexico during the Deepwater Horizon spill led to several follow-up studies aimed at attempting to move these techniques from qualitative descriptions to quantitative assessments.

### Seep Mapping on the *Okeanos Explorer* in the Gulf of Mexico

Immediately following the Deepwater Horizon explosion and leak of the Macondo well head, we proposed the use of a 30 kHz multibeam sonar with water-column mapping capability (Kongsberg Maritime EM302) as a potential tool for mapping deep oil and gas spills and monitoring the well head for leaks. At the time of the spill, such a system was not available (the EM302-

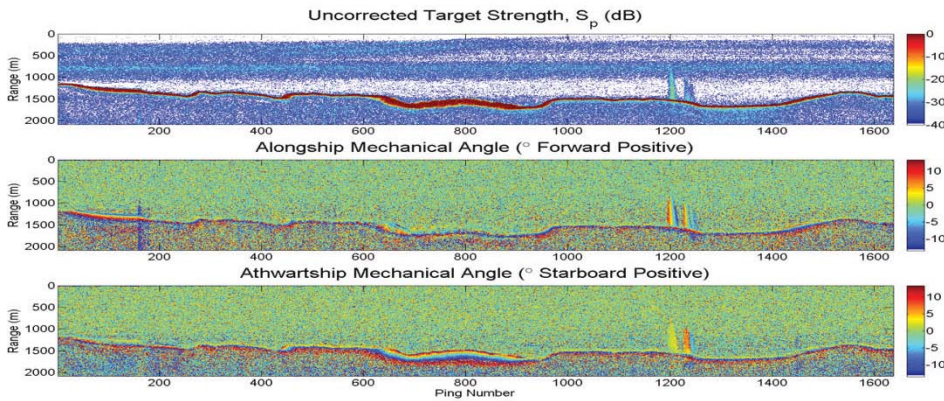

Figure 5-10. Seeps observed with an 18-kHz Simrad EK60 aboard NOAA Ship *Okeanos Explorer* during EX1105 in the northern Gulf of Mexico. Two plumes are visible in the vicinity of ping number 1200. Scattering strength (top) and target mechanical angles (middle, bottom) are used to detect, georeference, and characterize seeps.

equipped *Okeanos Explorer* was deployed in Indonesia) and thus we used 18 and 38 kHz fisheries sonars. These sonars proved very effective at identifying gas seeps and leaks but have limited areal coverage and limited spatial resolution as compared with the multi-beam sonar. In August/September 2011, we finally had the opportunity to bring NOAA Ship *Okeanos Explorer* to the Gulf of Mexico in order to test the EM302 water column mapping capability for detecting and characterizing methane gas seeps. We also carried out comparisons against data collected with a Simrad 18 kHz EK60 split-beam echosounder (a system known for finding seeps in the Gulf of Mexico) which was purchased and installed on the *Okeanos Explorer* for this cruise. During this relatively short cruise (less than two weeks of active mapping), a Center team led by Tom Weber and including Jonathan Beaudoin, Glen Rice, Kevin Jerram and Maddie Schroth-Miller mapped 17,477 km<sup>2</sup> of the northern Gulf of Mexico making 573 seep observations (some of which were repeat observations of the same seep) with the EM302. Working in 1200-2500 water depths, Weber developed seep detection algorithms while Beaudoin developed software that allowed the precise geolocation of the targets for presentation in a 3D context. We found that we were able to most reliably detect seeps over a swath that was approximately twice the water depth—at farther ranges reverberation from the seafloor tended to dominate the return from the seep, significantly reducing the likelihood of detection. The results from this cruise demonstrated a new midwater mapping technology for the *Okeanos Explorer*, and also suggested that widescale mapping of seeps in the deep Gulf of Mexico—an objective that is important for both scientific and industry management perspectives—is viable.

In 2012, we followed up these studies with another program on the *Okeanos Explorer*. In April 2012, Tom Weber, Larry Mayer and Kevin Jerram, guided (from shore) the science behind ROV dives aboard the *Okeanos Explorer* aimed at groundtruthing the midwater acoustic mapping efforts. Center involvement led to the development of a direct methane flux measurement device that was successfully deployed during the cruise from Little Herc (thanks to some outstanding engineering efforts by the NOAA Office of Ocean Exploration ROV team), as well as a calibrated

bubble grid aimed at measuring bubble sizes and general methane gas seep exploration using EM302 and EK60 data as acoustic guides for the ROV expeditions. Data collected during this cruise greatly increased our ability to properly interpret and analyze acoustic data collected during midwater mapping expeditions in the same area.

In 2013, we continued to analyze acoustic and ROV data collected with the *Okeanos Explorer* in our attempts to further our capabilities to detect, localize, and quantify gas seeps using split-beam and multi-beam echosounders (Figure 5-10). Both of these systems provide complementary data—we exploit the multibeam for its wide field of view and accurate positioning capability in order to examine the locations, morphologies, and rise heights of the plumes, and we exploit the split-beam echosounder to provide calibrated measurements of seep target strength (Figure 5-11) that can be related to gas flux if we know the bubble size distribution. A comparison of gas flux estimates made from acoustic and ROV direct capture methods

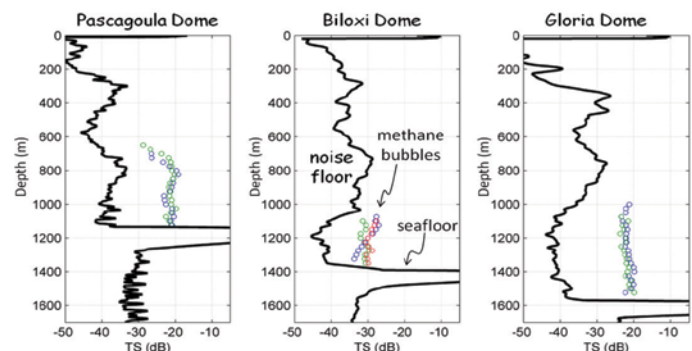

Figure 5-11. Split-beam echosounder measurements of gas plume target strength (colored circles) and background noise floor (black line) from seeps observed in the Gulf of Mexico.



has shown a remarkably close agreement (within 20%) from a seep on the Pascagoula Dome in the Gulf of Mexico, which is an encouraging result.

Another aspect of this work is the variability of the observed seeps, both in terms of the seep presence and absence and also in terms of the variations in flux. To this end, graduate student Kevin Jerram has been working to improve the localization of plumes and the estimation of associated seep source locations on the seafloor by employing attitude compensation and refraction correction methods similar to those used in multibeam echosounder processing routines. As with multibeam echosounders, estimates for installation offsets of the EK60 transducer relative to the vessel inertial navigation system are of critical importance for accurate seep localization.

Jerram's master's thesis (under the supervision of Tom Weber) focused on the estimation of angular offsets by comparing seeps observed with the split-beam EK60 to simultaneous benchmark observations made with the

*Okeanos Explorer's* Kongsberg EM302 multibeam echosounder (for which all offsets have been determined by patch testing). Using this approach, he has been able to localize seeps within the split-beam's 11° beam to an accuracy that is similar to that achievable with the 1°x0.5° degree EM302. In approximately 1600 m water depth, seep locations estimated using the resulting EK60 transducer offsets agreed to within ~15 m of those determined from patch-tested EM302 data and fell within the scatter of EM302 seep location estimates for repeat observations. The successful demonstration of seep localization with the EK60 was a main topic of a presentation given by Jerram in early June at the International Congress on Acoustics, a joint meeting of the Acoustical Society of America and Canadian Acoustical Association, in Montréal, Québec, for which he was awarded 2nd Place—Best Student Paper for Acoustical Oceanography.

Jerram also developed routines for seep characterization including beam pattern correction for true target strengths of sample volumes in bubble plumes (Figure 5-12). These methods are cornerstones of Jerram's master's thesis and are presently being used to evaluate spatial and temporal variability of positions and target strength profiles for seeps observed repeatedly during EX1105 and EX1202 Leg 3.

The Center also supported an Exxon-Mobile funded gas seep mapping cruise in the western Gulf of Mexico aboard the *E/V Nautilus* in July. The objectives of this cruise were to localize seeps and to characterize the seep environment using bathymetry, seabed backscatter, and sub-bottom profiler data. This information was then used to guide a follow-up cruise on the *Nautilus* aimed at direct sampling with an AUV and an ROV.

## Midwater Mapping of Fish Behavior

(For information—funded by non-NOAA sources)

We briefly report on this ONR-funded project because of its relevance to many NOAA fisheries issues and its use of NOAA sonar systems (the ME-70). The goals of the project are to develop new models of the behavior of fish aggregations, including the fission/fusion process, and to describe the echo statistics associated with the random fish behavior using existing formulations of echo statistics. To do this, ME70 data describing pollock aggregations collected aboard the NOAA Ship *Oscar Dyson* are being exploited to help groundtruth behavior models. The ME70 data analysis has been focused on data collected in the Eastern Bering Sea (EBS) during 2010 and 2012 (data made available courtesy of Chris Wilson, NOAA AFSC). Most of the data were

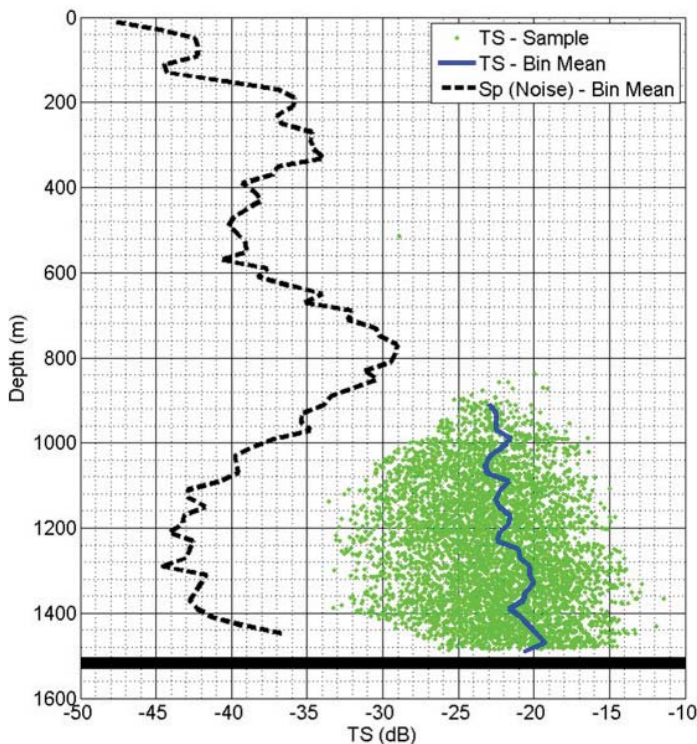

Figure 5-12. Depth-binned mean target strength (TS) profile of a seep observation and background noise environment. Changes in plume target strength with depth may correspond to changes to gas bubble volume related to gas transfer to the water column and hydrostatic pressure changes. Bubbles are not observed acoustically to ascend to depths shallower than 900 m. This limit of observation may be due in part to increased ambient noise (dashed line) related to biological acoustic scatterers at this depth.



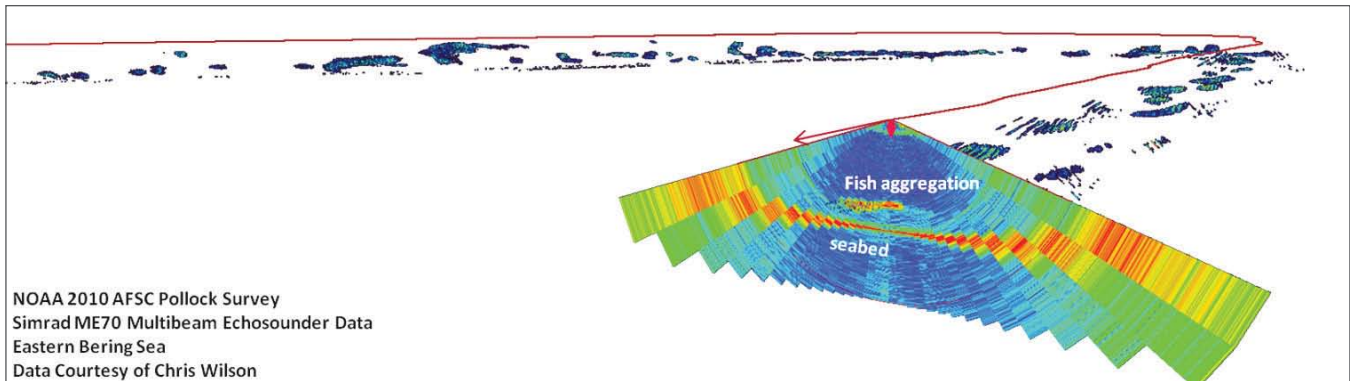

Figure 5-13. Example of Simrad ME70 multibeam data collected by NOAA-AFSC in the Eastern Bering Sea. A single ping of data representing a 'slice' of the water column is shown in the foreground. Target detections representing aggregations of walleye pollock are shown in the background. The ship's trackline is shown in red.

collected along widely spaced ( $\sim 40$  km) transects and, for the purposes of this research, are considered to represent a snapshot of the pollock aggregations present in the EBS. During the 2012 data collection effort, NOAA-AFSC also conducted repeat transects at our request and with our guidance on two occasions. This resulted in  $\sim 1$  nmi long transects that were repeated every 10-15 minutes, with 24 transects on the first occasion and 14 transects on the second occasion. Data analysis has thus far been focused on population level statistics, where comparisons to behavioral models may help define or bound aggregation behaviors (e.g., fusion and fission rates).

ME70 data representing eight days of survey effort in July 2010 were analyzed to form clusters of volumetric backscatter representing mid-water pollock aggregations (Figure 5-13). These data cover a region extending

from  $176^{\circ}\text{W}$  to  $179.5^{\circ}\text{W}$  and  $58^{\circ}\text{N}$  to  $62.5^{\circ}\text{N}$ . Mid-water trawls ( $N=43$ ) conducted in this region caught 98% pollock by weight. 49,650 clusters were extracted from the ME70 data for the eight-day period. Histograms of their effective size,  $V^{1/3}$ , vertical extent, and horizontal extent are shown in Figure 5-14. Also shown are best fits of the data to the models of Anderson (1981) and Niwa (2003), and to Bhatia et al. [submitted]. Neglecting issues that may arise from the ME70 finite field of view and range/angle-dependent resolution, the data suggest that the pollock aggregations have a high aspect ratio: the mode of the horizontal extent is approximately six times greater than the mode for the maximum vertical extent. The data can be fitted to the Anderson model, which assumed disk-like aggregations of fish and modeled the diameter of schools, quite closely.

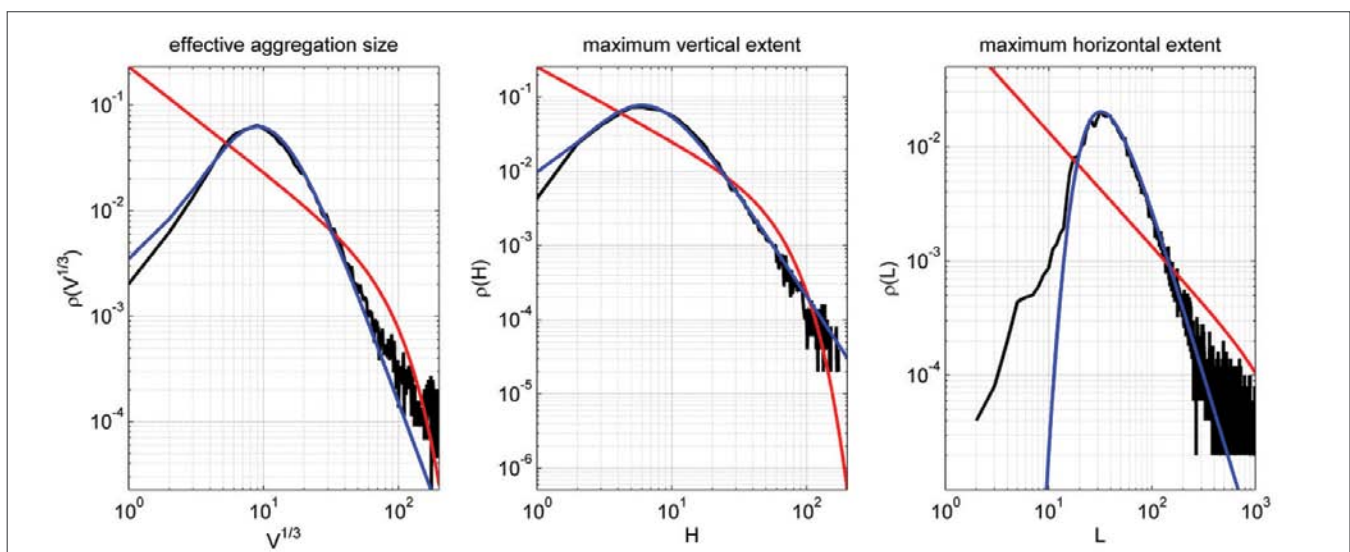

Figure 5-14. Black line: Size distributions for effective size, maximum vertical extent, maximum horizontal extent. Red line: Niwa's model. Blue line: Anderson's model. Note that the axes change for each figure.

## Theme 4 – IOCM

### Developing Tools, Protocols, Non-Standard Products, and Approaches that Support the Concept of “Map Once – Use Many Times,” i.e., Integrated Coastal and Ocean Mapping

A critical component of the Center’s new proposal was to maintain an Integrated Ocean and Coastal Mapping (IOCM) Processing Center that would support NOAA’s new focused efforts on Integrated Ocean and Coastal Mapping as outlined in the Coastal and Ocean Mapping Integration Act of PL-111-11. The new IOCM Center brings to fruition years of effort to demonstrate to the hydrographic community that the data collected in support of safe navigation may have tremendous value for other purposes. It is the tangible expression of a mantra we have long-espoused—“map once – use many times.” The fundamental purpose of the Center is to develop protocols for turning data collected for safety of navigation into products useful for fisheries habitat, environmental studies, archeological investigations, and many other purposes and, conversely, to establish ways to ensure that data collected for non-hydrographic purposes (e.g., fisheries, ocean exploration, etc.) will be useful for charting. Our goal is to have NOAA employees from several different NOAA lines and divisions (NOS Coast Survey, Sanctuaries, Fisheries, Ocean Exploration, etc.) at the Center and have them work hand-in-hand with our researchers to ensure that the products we develop at the Center meet NOAA needs. The NOAA employees will develop skills in the use of these products so that they can return to their respective divisions or the field as knowledgeable and experienced users. Eventually, we envision that nine to eleven NOAA employees will be assigned to the IOCM Processing Center.

Representing the Office of Coast Survey at the Center, Glen Rice and Sara Wolfskehl have been partnering with a number of Center staff members to design workflows for IOCM products and to provide a direct and knowledgeable interface with the NOAA fleet to ensure that we address high-priority issues and that the tools we develop are relevant for fleet use. In addition, Glen provides a direct link when specific operational difficulties arise in the field, allowing Center personnel to take part in designing an appropriate solution.

In 2013, our IOCM efforts focused on collaborations with the Office of Coast Survey, Office of Ocean Exploration and Research, National Marine Fisheries Service, and with NOS’s Marine Modeling and Development Office. Many of the efforts previously described (particularly those described under HABITAT, MIDWATER MAPPING, LIDAR AND DATA PROCESSING themes) can just as easily be listed under the IOCM theme. Here we focus on those projects that, for the most part, have been specifically incorporated into NOAA’s IOCM projects.

### Backscatter from Hydrographic Vessels

#### Hydrographic Launches

The collection of quality backscatter data from Office of Coast Survey hydrographic MBESs is a primary focus for the NOAA Integrated Ocean and Coastal Mapping effort. This includes both the acquisition of useful backscatter data with all the information needed for post processing as well as a streamlined workflow to quality check the acquired data. This also supports preliminary products for advertising data availability because many past projects had no backscatter included. In support of this goal, Glen Rice, in collaboration with Center scientists, has developed a NOAA OCS backscatter workflow, applying tools and principles developed at the Center to NOAA hydrographic launches working

in the field. An effective workflow for quality checking backscatter has now been established. The missing link between the NOAA hydrographic workflow and a solid backscatter processing algorithm was developed in 2012 through Fledermaus GeoCoder Toolbox plug-ins (see DATA PROCESSING theme). This workflow combines bathymetry from CARIS HIPS with raw backscatter files collected from a number of sources. While improvements to this backscatter workflow continue to be implemented, a procedure and introductory training have now been passed onto the NOAA Hydrographic Processing Branches for implementation. The Branches continue to use the workflow provided with IOCM Center support for accommodating the many changes in the processing software. QPS FMGT (see DATA PROCESSING theme) is constantly being updated, some of which is in direct support of improvements to the NOAA workflow. While some difficulty still exists with

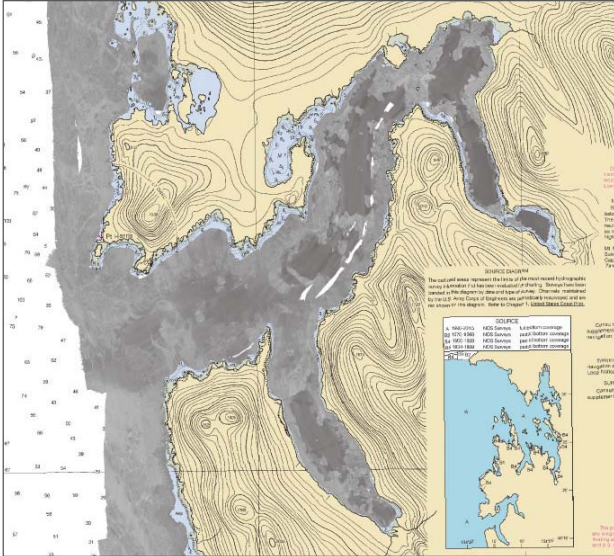

Figure 6-1. Processed backscatter mosaic from survey H11818, collected by the NOAA Ship *Fairweather* in 2010.

properly combining uncalibrated systems due to clear offsets in the product mosaic, LCDR Briana Welton's work at the Center (see Backscatter section of DATA PROCESSING theme) is directed at solving this outstanding issue.

## Other NOAA Vessels

Center efforts to help NOAA generate high-quality backscatter data extend beyond the hydrographic launches to other NOAA vessels with multibeam sonars. Our ongoing work with the NOAA Ships *Oscar Dyson* and *Fairweather*, in direct support of IOCM efforts, has been described in earlier progress reports and in this year's report under the HABITAT Theme (i.e., the work of Jodi Pirtle and Tom Weber using *Oscar Dyson* data) and in the Backscatter section of the PROCESSING theme (the NEWBEX project). Building on the work of Jonathan Beaudoin to correct backscatter problems on the NOAA vessel *Fairweather* (see 2012 progress report), Sarah Wolfskehl has been assigned

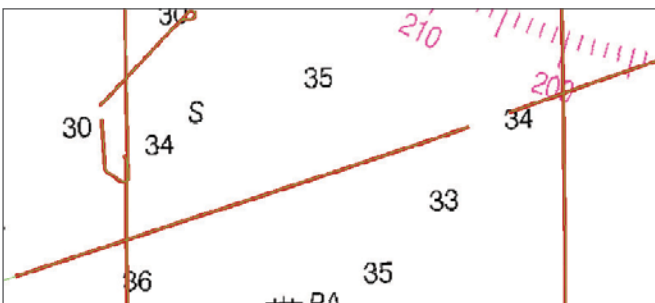

Figure 6-2. Red lines represent track lines run by the *Dyson* in areas of the Bering Sea where sparse hydrographic data exists, indicated by white space on the chart.

the task of processing backscatter from the *Fairweather* (Figure 6-1) and submitting the data to the National Geophysical Data Center (NGDC) for archiving. In doing this processing, Wolfskehl will test and review the current procedures and address concerns expressed by shipboard processors.

## Bathymetry from the NOAA FSVs

The collection of multipurpose data from NOAA hydrographic vessels (e.g., backscatter data that can be useful for habitat mapping) is only one aspect of the IOCM effort. Just as importantly there is the design of protocols to ensure that as the fisheries vessels use their multibeam sonars they produce bathymetry and other outputs that can serve hydrographic and other purposes. This effort was epitomized in 2011 when Tom Weber, Jodi Pirtle, and Glen Rice demonstrated that the fisheries sonar on the NOAA Ship *Oscar Dyson*, designed for mid-water fisheries studies, could also be used to provide hydrographic quality bathymetry, map the seafloor for trawlable/untrawlable habitat (see HABITAT Theme), and identify gas seeps. In one example, during a pollock survey, a Danger to Navigation (DTON) was identified from the data collected by the fisheries sonar (see the 2011 Progress Report).

The approaches developed at the Center are being put into practice as Sarah Wolfskehl continues to process and submit bathymetry collected with the Simrad ME70 on the fisheries vessel *Oscar Dyson* (Figure 6-2). In August 2013, Wolfskehl submitted two *Dyson* surveys to the Office of Coast Survey, W00219 to the Atlantic Hydrographic Branch and W00265 to the Pacific Hydrographic Branch. She continues to process ME70 data collected by the NOAA Ship *Oscar Dyson* in the Bering Sea, while troubleshooting system errors and improving the quality of the data.

The NOAA Ship *Henry Bigelow*, which operates in the Northwest Atlantic, has a Simrad ME70 fisheries sonar but, unlike the ME70s in the rest of the NOAA Fisheries Survey Vessel fleet, the *Bigelow* also has the Kongsberg bathymetry module to support the collection of bathymetry with this fisheries multibeam. The ship has begun to actively collect bathymetry, but does not have the survey expertise on board to ensure quality data collection. *Bigelow* personnel have been working with both the IOCM Center and HSTP to gain the support and expertise they need, including OCS training coordinated by HSTP. They have been working to calibrate their system to meet IHO standards, arrange hydrographic training for personnel, and develop procedures for submitting the data to NGDC for archiving and access by OCS and others.



With the exception of the *Bigelow*, the collection of bathymetric data from the ME70 fisheries sonars has depended on research code developed by Tom Weber at the Center. In an effort to transfer this capability to “off-the-shelf” software, Glen Rice and Sarah Wolfskehl have been working with Industrial Partner Hypack to test Hypack’s integration of Weber’s ME70 bottom detection code with their acquisition software. Incorporating Weber’s code into Hypack would enable ship personnel to produce bathymetry and visualize ME70 data in real-time. This capability within Hypack would offer an inexpensive option for other FSVs to generate bathymetry data and produce an output file in a format that is easily accepted into the Office of Coast Survey hydrographic pipeline. Initial testing aboard the *Bigelow* was limited, as Hypack was unable to connect to the ME70. Since then, Hypack has received a sonar simulator from Simrad and development continues.

## Tools for Optimizing Third Party Bathymetric Data

One of the primary mandates of the IOCM effort is to establish protocols and tools for using data collected by non-hydrographic vessels for hydrographic purposes. A challenge of this mandate is the reality that, often times, non-hydrographic vessels have not collected appropriate environmental data (e.g., sound speed) or performed appropriate sonar calibrations (e.g., patch tests) to make the data usable for hydrographic purposes. The Center has been working for some time now on tools to help address these challenges (see Sound-Speed section of DATA PROCESSING theme) and has now embarked on several IOCM-specific exercises aimed at developing solutions to this problem.



Figure 6-3. Ship trackline of the USCGC *Hickory* for which a 17-day synthetic water mass was derived from WOA2001.

## SVP Uncertainty Estimation for NOAA Ship *Pisces*

The bathymetric data collected on NOAA Fisheries Survey Vessels do not always meet the standards set by the NOAA Office of Coast Survey for hydrographic charting. Specifically, sound speed casts do not always meet the four-hour time period recommended in the Field Procedures Manual and the uncertainty values recommended for that time period. Wolfskehl, under the supervision of Rice, has been tasked with processing and preparing an IOCM data set from NOAA Ship *Pisces* and, as part of this task, has been charged with computing total propagated uncertainty (TPU) estimates for the ME70 soundings.

There is still no standard method for using field observations of sound speed profiles to estimate the sounding uncertainty due to spatio-temporal oceanographic variability. This is further complicated in the case of the *Pisces* data set since the sound speed observations (largely from XBT probes) were very sparse and much of the sounding data were from ship tracklines. The undersampling of the water column leads, of course, to poor refraction corrections to the soundings. Additionally, it creates difficulties when attempting to use the water column observations themselves to estimate the uncertainty.

Beaudoin has proposed a two-stage procedure that has been used with this type of data set before (2010, NOAA Ship *Oscar Dyson* ME70). First, a ray tracing Variability Analysis using all sound speed profiles allows for an estimate of an upper bound of the sounding uncertainties associated with the undersampled water column. Then the estimate is used to compute an

equivalent sound speed sensor bias uncertainty that can then be used in the Hare-Godin-Mayer (HGM) TPU model implementation in Caris HIPS. A new procedure and workflow is emerging which we hope to formalize and bring to HSTP for implementation in standard NOAA SVP processing tools such as Velocity.

## Synthetic SVP Casts for USCG Single Beam Sonar Data Collected in the Arctic

Grant Froelich from NOAA’s Pacific Hydrographic Branch, has, under the direction of David Zezula, been investigating using modeled sound-speed correctors for an Arctic single beam data set collected by USCGC *Hickory*. Froelich contacted HSTP

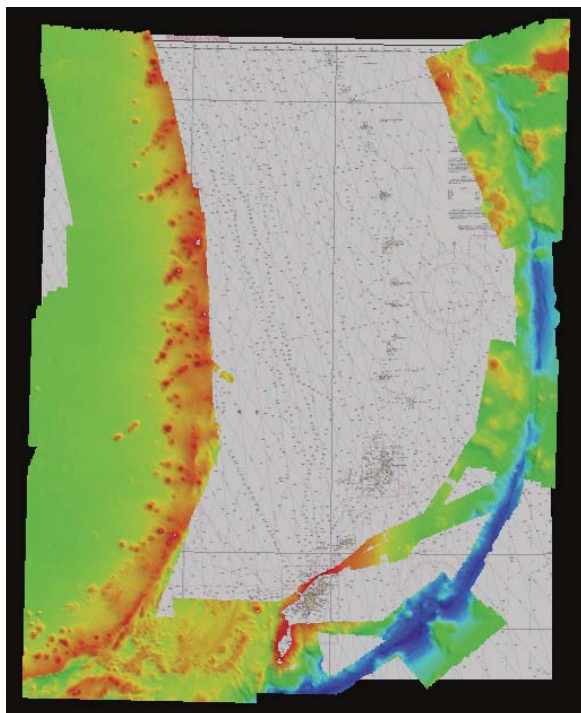

Figure 6-4. W00270 digital terrain model overlaying chart 81004.

and Beaudoin to inquire about having a synthetic sound- speed profile data set generated for *Hickory's* single beam tracklines. HSTP could only provide synthetic SVPs from the 1° World Ocean Atlas (WOA) and Beaudoin offered to generate an SVP data set from the 1/4° WOA. Froelich provided the time-tagged ship track and Beaudoin used his WOA2001 lookup programs to generate the synthetic water column model for the entire survey. WOA2001 profiles were extracted using a nearest-neighbor profile extension which limited consecutive queries to be at least 5 NM apart to constrain the total number of generated sound-speed profiles. For the 750,315 navigation points provided, only 441 sound speed profiles were generated (Figure 6-3). Profiles were visually examined for quality assurance purposes and nothing unusual was noted. The sound-speed profiles were then resampled to 1-m depth resolution through linear interpolation and were then converted into a single Caris HIPS SVP file for use in post-processing.

As the Arctic is poorly charted, it was felt that having data with a synthetic sound-speed corrector was better than having no data at all in uncharted areas. Further work must be done, however, to validate this approach, including providing uncertainty estimates associated with the synthetic water column model, and to develop institutional guidelines that can provide direction to the hydrographic branches to help decide when such methods are acceptable.

## Patch Test and Hydrographic System Calibration of NOAA Ship *Henry Bigelow*

As part of our efforts to better calibrate sonars on non-hydrographic vessels, Sarah Wolfskehl accompanied Physical Scientist Matt Wilson and Simrad representative Gregg Juergens aboard the NOAA Ship *Henry Bigelow* for a ME70 system calibration. Prior to departure, Simrad installed a SIS system upgrade and new topside unit. During the three days underway, the ship's static draft was determined, the POS/MV was reconfigured, the GAMS subsystem was calibrated, and two patch tests were performed. A reference line run post-calibration was compared to data collected by the hydrographic platform NOAA Ship *Thomas Jefferson*. The data sets agreed very well and the ME70 data met IHO Order 1A standards. The *Bigelow* plans to collect IHO Order multibeam data with their ME70 when compatible with their primary operations and is working with NGDC and OCS to establish procedures, training, and a pipeline for getting the data off the ship.

## Use of ECS Data for Charting Purposes

Epitomizing the concept of IOCM is the multipurpose use of data collected by Center scientists in support of establishing the limits of a potential extended continental shelf as defined by article 76 of the Convention on the Law of the Sea (see LAW OF THE SEA theme). As part of our Law of the Sea Mapping efforts, in 2006, 2007, and 2010, Center scientists surveyed the foot of the slope surrounding the U.S. Jurisdiction of the Mariana Islands (see 2006, 2007, 2010 progress reports for details). The data were collected to NOAA bathymetric full bottom coverage standards. Recently, the Office of Coast Survey accepted the responsibility of the nautical chart in that region from the U.S. Navy. In the interest of "map once - use many times," the archived Mariana data at UNH was reprocessed to meet NOAA Hydrographic Specifications and Deliverables for charting and was submitted to the Office of Coast Survey as W00270 to update the chart (Figure 6-4).

## Theme 5 – Visualization

### New and Innovative Approaches for the 3D and 4D Visualization of Hydrographic and Ocean Mapping Data Sets, Including Better Representation of Uncertainty, and Complex Time- and Space-Varying Oceanographic, Biological and Geological Phenomena

We continue to have a very strong focus on the development of innovative approaches to data visualization and the application of these approaches to ocean mapping and other NOAA-related problems. Over the past few years, the visualization team (Arsenault, Butkiewicz, Plumlee, St. Jean, Mihtsentu, Schwehr, and Sullivan), under the supervision of Lab Director Colin Ware, has produced a number of novel and innovative 3D and 4D visualization tools designed to address a range of ocean mapping applications (see earlier progress reports). This year, efforts have focused on the further development of a new interactive 3D/4D visualization environment—Virtual Test Tank 4D (VTT4D)—specifically designed to help oceanographers, hydrographers, ocean engineers, biologists, and others interpret complex data from a variety of sensors, models, and data sets.

#### Interactive Exploration/Visual Analysis System for Complex Time-Dependent Flow and Other Models—Virtual Test Tank 4D (VTT4D)

Thomas Butkiewicz and Colin Ware continue to refine their advanced flow visualization techniques, seeking tools to better communicate the complex output of today's increasingly high-resolution oceanic and atmospheric forecast simulations. By applying well-founded perceptual theory to the design of visual representations, the contents of these models can be effectively illustrated without overwhelming the viewer. The integration of non-traditional interfaces, such as multi-touch displays and motion-capture, supports more efficient and flexible interactions that can overcome the challenges often encountered when attempting to navigate and manipulate within 3D environments. Finally, a number of new analytical tools allow the user to leverage the predictions of these simulations to support other research projects.

Virtual Test Tank 4D (VTT4D) is a new project that consolidates the various 3D and 4D flow visualization techniques that Butkiewicz and Ware have developed into a single application that is intended to be shared with other researchers and the public (Figure 7-1). It replicates many of the analytic abilities and model support found in the previous Center flow visualization projects, but does so within an updated code base in an easy to distribute application. Its increased flexibility allows users outside the Center to utilize these 4D visualizations with their own data, without the need for custom programming on our end. It also implements many new features to support analysis and to aid presentation.

A major issue hindering the use of the Center's advanced flow visualization applications by outside collaborators has been reliance on specialized hardware, most significantly a custom-built stereoscopic multi-touch display and expensive stereoscopically-enabled graphics cards. VTT4D reduces these dependencies by supporting, but not relying on, specific hardware. For example, VTT4D switches easily between monoscopic 3D and stereoscopic 3D (which requires professional-series graphics cards supporting quad-buffer stereo). All interactions are possible solely with mouse and keyboard, with multi-touch interaction being transitioned from vendor-specific drivers to generalized Windows-level touch support.

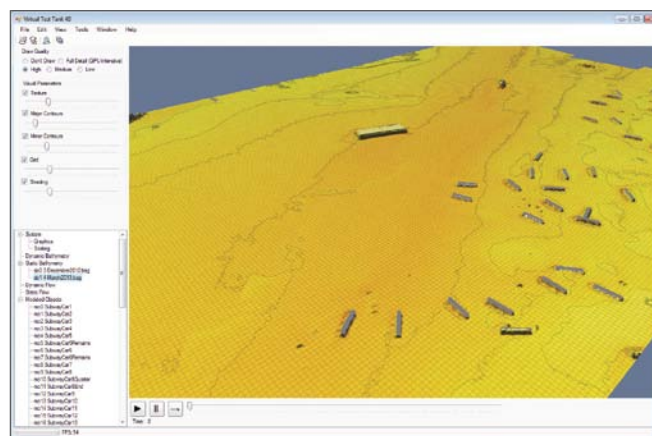

Figure 7-1. A screenshot of the new VTT4D interface.



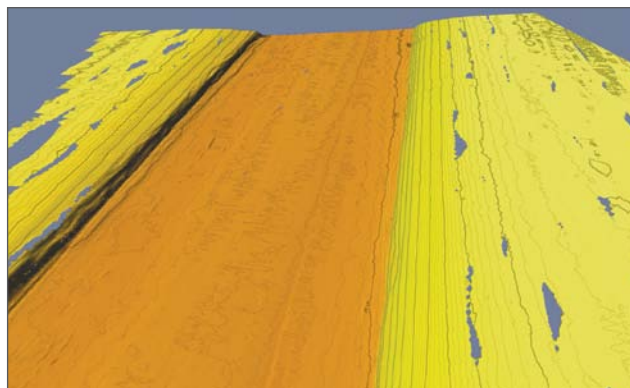
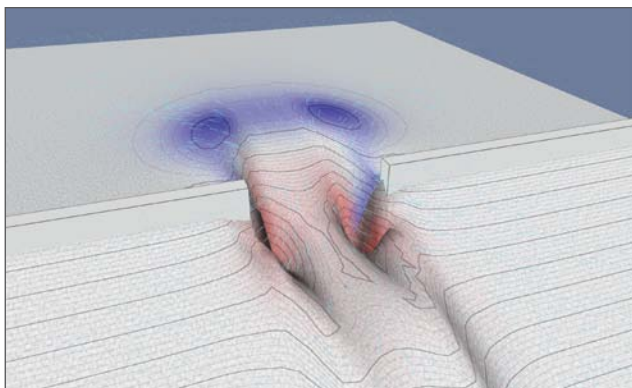

Figure 7-2. VTT4D animating the dynamic bathymetry and flow contents of the Test Inlet model from the Ocean-Atmosphere-Wave-Sediment Transport (COAWST) modeling system (*left*). Bathymetric surfaces can also be rendered in shaded view (*right*) which provide per-pixel contours, surface grids, and texturing. These options not only increase the visual appeal, but they add details that enhance stereoscopic perception and help convey curvature.

New (optional) interaction methods will also include computer-vision-based hand and body tracking. Butkiewicz is currently participating in Microsoft's pre-release developer program for the next generation Kinect for Windows device, and will be integrating support for it within VTT4D. This will enable users to navigate using intuitive hand gestures, and manipulate their datasets with digital versions of their hands that can naturally form complex shapes (that can be used as cutting planes, etc.) much faster than through traditional mouse interaction.

Previous visualization research applications were hard-coded to support loading particular flow models (e.g., RTOFS and NCOM). VTT4D is more flexible and allows the user to import many common data models and formats without the need for recompiling the source code to support new datasets. This should satisfy many of the requests the Center has received from outside collaborators to visualize their particular datasets, many of which have gone unfulfilled due to the time required to hard code support for each particular format.

Beyond just replicating existing visualization techniques, VTT4D serves as the test bed for many research projects. One new focus in VTT4D is the analysis of sediment transport simulations that produce tightly integrated dynamic flow models and dynamic bathymetry models. These simulations are the perfect application for 4D visualization, as everything is changing and temporal relationships are significant. Whereas previous applications displayed static bathymetry, VTT4D supports multiple dynamic terrain models that can fluidly morph as time parameters are changed. These can be loaded from simulation output, or created as desired, wherever multiple static bathymetry datasets overlap. Color and textures are applied to the terrain model to highlight the salient features of erosion and deposition occurring in the simulation (Figure 7-2). Simulations of this sort may be very useful for understanding the frequency at which hydrographic surveys might be necessary in dynamic seafloor environments.

VTT4D's analytical usage has been demonstrated in supporting the ongoing project between the Center

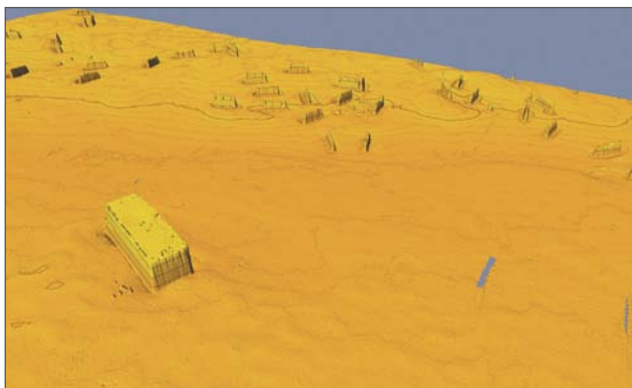

Figure 7-3. Static bathymetry of the Redbird artificial reef site as displayed in VTT4D. Rectangular objects are the bathymetric rendering of subway cars sunk to serve as artificial reefs.



Figure 7-4. Animated dynamic bathymetry at the Redbird reef site generated within VTT4D from five overlapping survey missions. Red areas are experiencing erosion, blue areas are deposition.

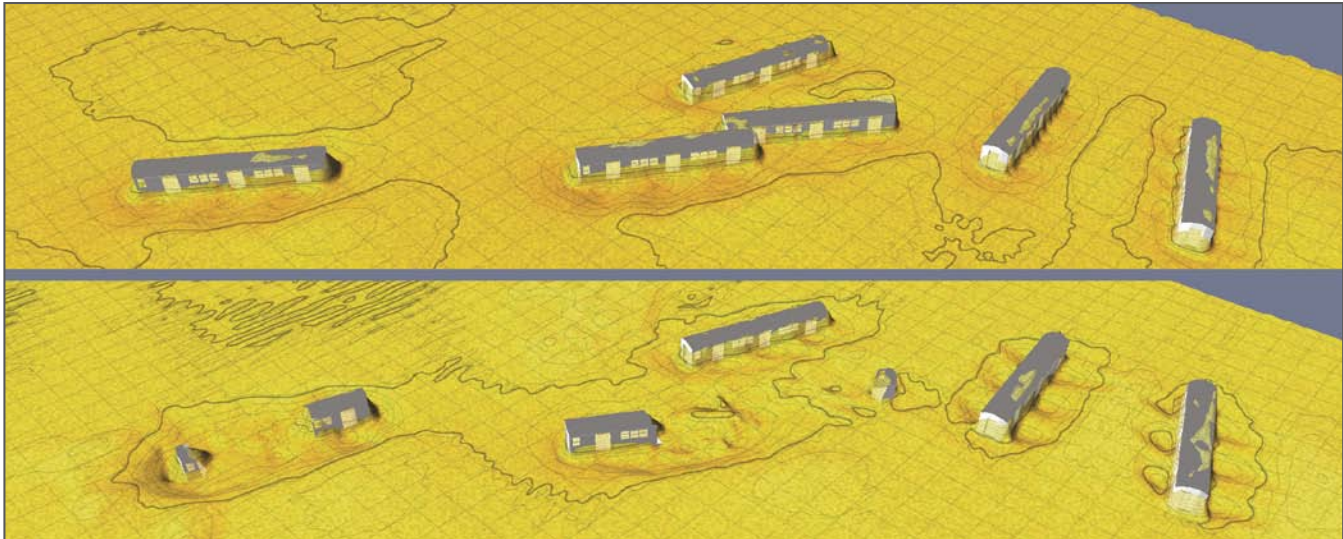

Figure 7-5. Pre- and post-Superstorm Sandy images of a section of the Redbird reef, showing significant movement and destruction of the subway cars, which have detailed models.

and the University of Delaware where the Redbird artificial reef site off the coast of Delaware Bay was mapped six times, including just before and just after Hurricane Sandy (see AUV Activities section of the SENSORS theme). Here it serves the important purpose of not

just displaying the collected data, but helping the user make sense of it and finding insight into the damage caused by Hurricane Sandy to the artificial reef objects and the seafloor. It also provides a clear demonstration of how the seafloor recovered over the following year.

The user begins by first importing the multiple digital terrain models (BAG files) containing the static bathymetry collected during each survey mission (Figure 7-3). The user can then select a region-of-interest and request a dynamic bathymetry model be generated (Figure 7-4). The system determines the highest resolution data available for that region, and then interpolates all other data to properly align. This results in a new dynamic bathymetry data object which is designed to best display temporal changes and is optimized for smooth animations between time-steps. To increase understanding and aid in presentation, the user can also load any number of modeled objects in the commonly used '.obj' file format, providing higher resolution imagery of debris or structures than the bathymetry itself reveals.

In the Redbird case, the user can load models of all of the subway cars, and use the provided tools to ensure that they are aligned. For objects that move, multiple time-steps can be entered, enabling animation.

Similarly, objects that change shape, such as subway cars breaking apart, are supported by modeling the individual pieces separately and tying them together as needed (Figure 7-5), as well as a detailed analysis of erosion/deposition around the objects (Figure 7-6).

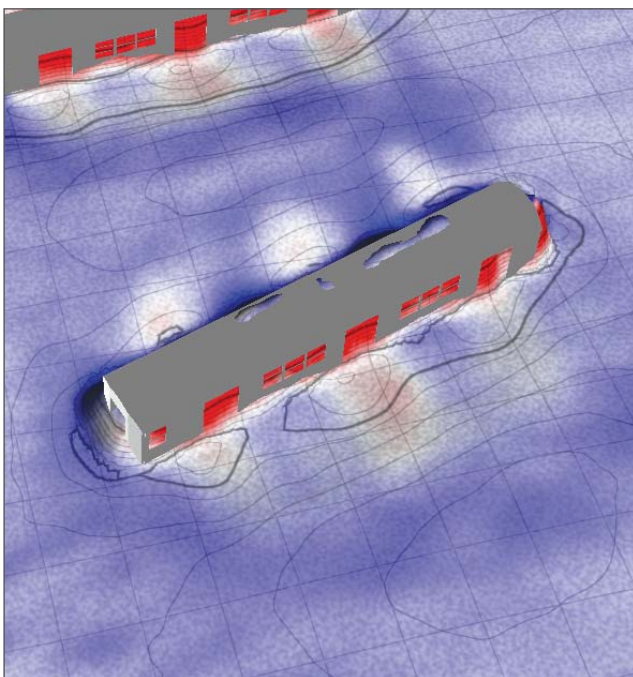

Figure 7-6. Erosion (red surrounded by white) can be seen occurring on either side of the subway cars in a pattern which is easily correlated to the locations of the doors as seen in the high resolution models of the cars. As the water flows through these openings, it becomes turbulent and scours the seafloor.



## Ecosystem Visualization Project

In collaboration with Sarah Gaichas, Robert Gamble and Michael Fogarty of NOAA's Northeast Fisheries Center, Colin Ware has begun two related initiatives to visualize fisheries-related ecosystem components for the Northeast U.S. As these tools evolve, they will be directly linked to our habitat mapping efforts.

### Food Web Visualization Northeast Fisheries

A food web visualization tool has been developed to help interpret the fisheries food web. The source data comes from fish stomach content analysis data gathered by NOAA over more than thirty years. We have entered into collaboration with Sarah Gaichas to develop methods for better understanding the interactions between the approximately 250 species in the database. Development was started with the help of Matthew Plumlee. The visualization shown in Figure 7-7 represents a snapshot of a single year's data using Ware's spring layout graph visualization software. The purpose of this project is to allow for interactive exploration of this data by region and to show how predator-prey relationships have evolved over time, hopefully leading to a better understanding of predator-prey interactions and, ultimately, to better management practices.

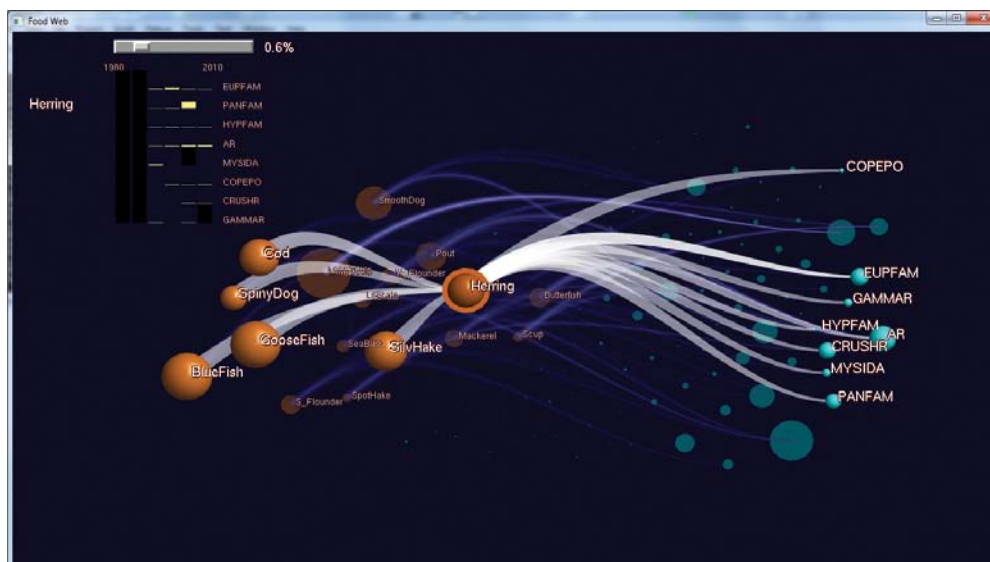

Figure 7-7. Food web visualization based on NE Fisheries data. Herring has been selected, herring predator species are shown to the left, herring prey species are shown to the right. Other species can be interactively selected to reveal their major predators and prey species. The layout adjusts automatically.

### Ecosystem Model Interactive Visualization

Michael Fogarty and Robert Gamble of Northeast Fisheries Center are developing an ecosystem based model of interactions between the key commercial fisheries species in the region (called Kraken). The Center team is developing an interactive visualization component for this model to be used as a planning tool by NOAA fisheries and the New England Fishery Management Council in order to make better-informed decisions relating to tasks such as setting fishing quotas. It will allow long term impacts (as modeled) of changes in policy to be easily visualized, understood, and presented to various stakeholders.

Our interactive visual interface enables stakeholders to adjust catch quotas for different modes of fishing, such as trawling or long-lining. The by-catch mix can be included in the model. It can show both direct and indirect effects. For example, sometimes reducing one species can result in a large change in the abundance of an apparently



unrelated species. The model can also include climate variables. Graduate student Carmen St. Jean is developing the visualization as her computer science master's thesis project under Ware's supervision. One view of the UNH Kraken interface is shown in Figure 7-8. The sliders on the panel enable a user to adjust the level of a particular kind of fishery and see the effects on the long term trends of all species.

The current prototype contains a number of alternative representations, including the possibility of showing uncertainty. Early in 2014, we plan to evaluate the effectiveness of various modes of presentation in allowing people to appreciate causal interactions. There is potential for major future developments, especially of the modeling initiative. In the future it is likely that the models will increase in sophistication and include variables such as changes in habitat due to climate change or storm events.

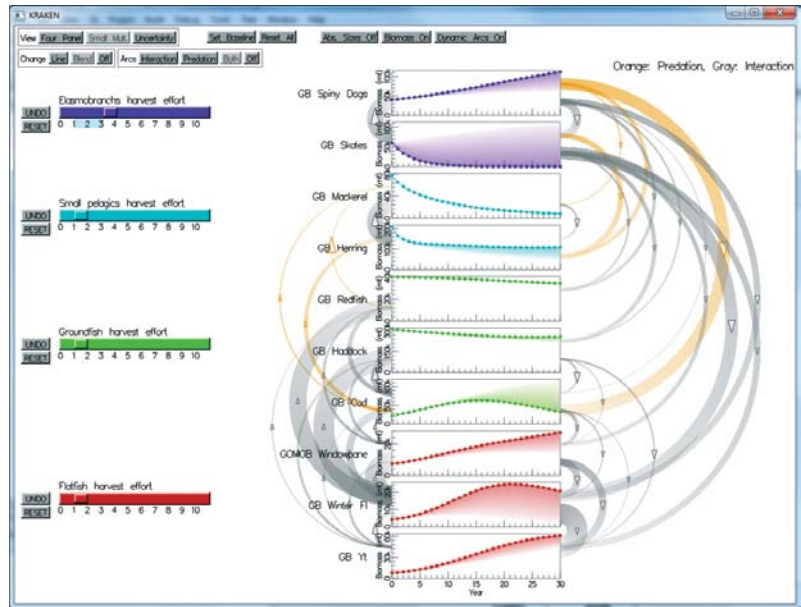

Figure 7-8. Interactive visualization of the forecast for ten Gulf of Maine species based on the NOAA KRAKEN model. The effects of increasing the catch of Elasmobranchs is visualized. The arcs show causal links in the model with predation in yellow and species competition in grey.

## Marine Mammals and Open Tag

The Center has had a long history of innovative visualization of the submerged behavior of marine mammals determined from sophisticated and expensive tags that contain accelerometers, magnetometers, pressure sensors, and hydrophones. Recently, low-cost tags for marine mammals have become available that contain gyroscopes in addition to the other sensors. The low cost of the new tags should encourage the deployment of many tags, with tag loss no longer regarded as catastrophic. In addition to giving more accurate angular velocity information, the gyroscopes will provide a means of decomposing acceleration measurements far more accurately. This, in turn, will enable better estimates of energy expenditure during various phases of foraging.

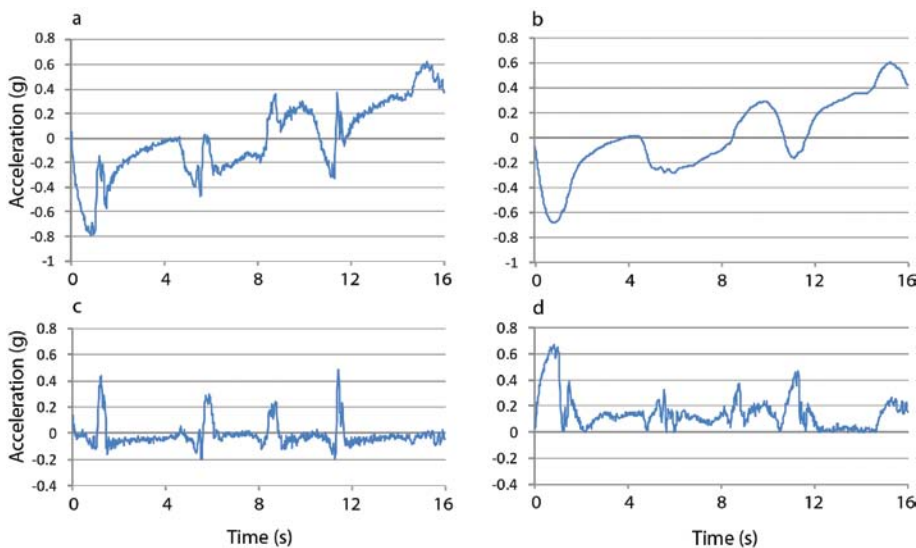

Figure 7-9. (a) The raw x-axis accelerometer data measured from a recording tag attached to a steller sea lion. (b) The x-axis component of the gravity vector obtained using tag gyros. (c) The difference between a and b revealing individual flipper strokes. (d) Results from an existing, and inferior, method currently in widespread (called ODBA).

Ware is adding enhanced capabilities to his TrackPlot software to improve kinematic analysis by making use of gyro data and simplify the analysis of data from multiple tags when simultaneously deployed. Results from a study run in Vancouver over the summer show that gyroscopes can greatly improve the estimates of body acceleration relating to flipper strokes in steller sea lions. An example from a single dive is shown in Figure 7-9. By incorporating gyro data, individual flipper strokes are revealed as propulsive pulses. Under conditions of steady swimming, the average accelerations computed using a new method approximate what is expected according to the theoretical drag for these animals.

## Flow Visualization

### Current Visualization for the Next Generation ENC

The VisLab has become heavily involved with the IHO Surface Currents Working Group (SCWG). The SCWG committee has been formed with the goal of developing an S-100 compliant product specification for the portrayal of tides and currents in electronic charts. Briana Sullivan helped construct a SCWG questionnaire that assessed different portrayals of currents—comparing conventional methods using arrow grids to renderings using equally spaced streamlines designed by Colin Ware according to the principles of optimal vector field display that he has been developing over the past few years (Figure 7-10). Survey results overwhelmingly supported the portrayal developed by the Center and efforts are currently underway to implement this.

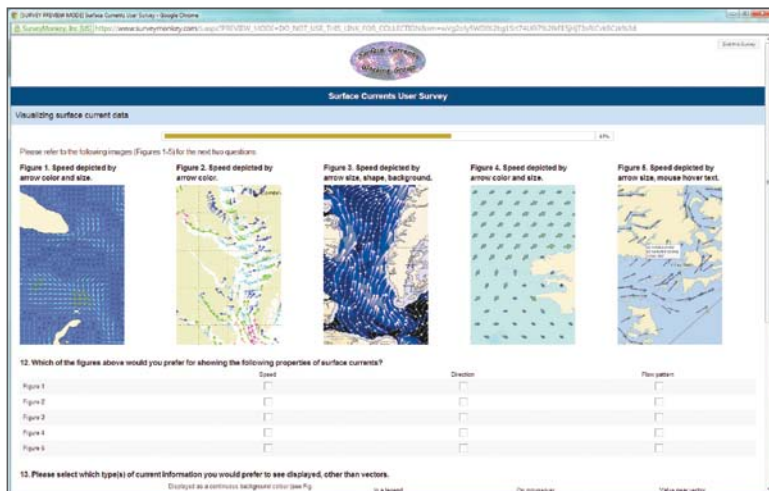

Figure 7-10. Survey distributed on behalf of the IHO SCWG to evaluate best means of portraying currents.

In order to demonstrate the compatibility of the new portrayal methods with modern web technologies, Roland Arsenault developed a JavaScript implementation using HTML5. This makes it possible to display the visualization against a Google maps background in a browser (Figure 7-11). He also implemented a simple compression scheme that can extract a subset of a larger model and compress it, making it suitable for mobile devices such as tablets and smart phones.

The effort is ongoing with a new study planned to develop some of the more detailed recommendations, such as color schemes suitable for electronic chart display, taking into account such factors as day, night, and dusk background color schemes, as well as preferred streamline spacing.

### Currents and Profiles

The National Operational Coastal Modeling Program (NOCMP) has developed operational flow models for estuaries located at various parts of the United States. These models provide nowcasts and short-term forecasts of important parameters such as temperature, salinity, current, and water level. NOCMP also provides a number of visualization tools, mostly 2D, to visualize the forecast of some parameters. The tools can be useful for fisheries and for recreational boaters and large ship navigation. However, the current visualization provided by NOAA through the NowCoast and other portals only show surface current. Graduate student Mezgeb Mitsentu is working under the supervision of Colin Ware on new techniques to represent the structure of estuaries flow in 3D. The proposed method is visualizing 3D flow patterns using 3D tubes following streamlines with multiple cross sections or profiles (Figure 7-12).

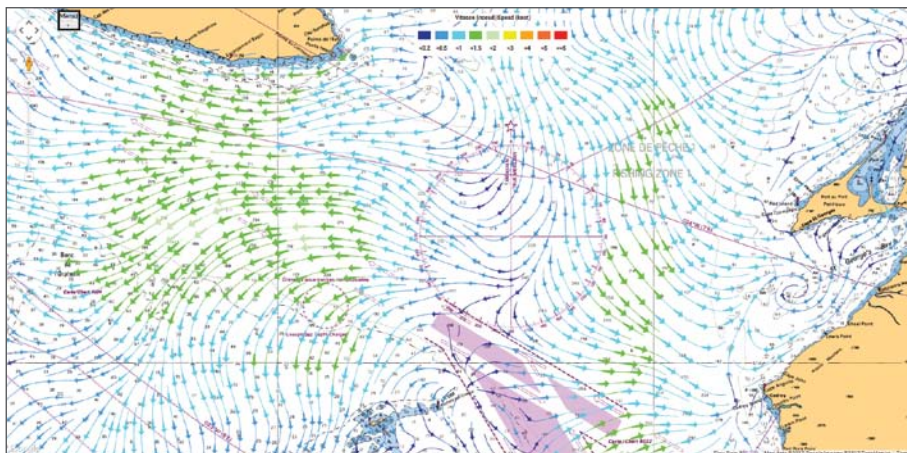

Figure 7-11. Flow patterns in the Gulf of St. Lawrence rendered over a chart background in a browser using Google Maps.

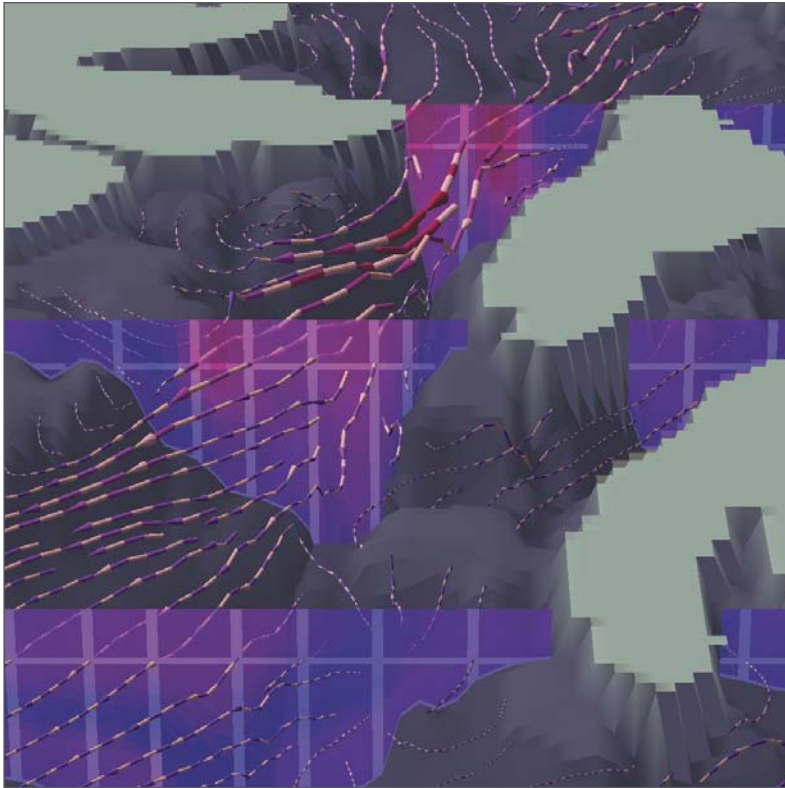

Figure 7-12. A multiple profile view showing current speed in Chesapeake Bay and currents rendered as tubes combined with partially transparent profiles. Data from NOAA Chesapeake Bay Operational Forecast model (CBOFS).

## GeoCamera

In 2010, the VisLab initiated a new project to use a georeferenced camera to map ice. The idea is to take into account ship attitude, heading, and position sensing, combine these with imagery from a digitally controlled camera, and mosaic the result onto an orthorectified image. This system was developed and first deployed on the R/V *Nathaniel B. Palmer* in Antarctica in the spring of 2010. It consisted of a Canon SLR mounted on a digital pan-tilt head attached to the railing on the Palmer's Ice Tower approximately 60 m above the waterline. This project was conducted in collaboration with Patrick Halpin of Duke University with Roland Arsenault as the primary Center developer. The preliminary results were encouraging. A set of 750 m radius images was created along the path of the ship with minimal distortion. Halpin successfully demonstrated that a supervised image segmentation method could be used to classify ice types, e.g., grease ice, brash ice, and consolidated ice.

In 2011, the geoCamera V2.0 was developed and deployed on our Extended Continental Shelf cruise on board the USCGC *Healy* in the high Arctic (see LAW OF THE SEA Theme). GeoCamera V2.0 was developed based on an Axis Q6034-E PTZ Dome Network Camera, an off-the-shelf security camera capable of operating in cold climates. Camera control, data collection, and processing were done on a Dell Precision M6300 located in the *Healy's* Future Lab. The camera was installed outside of the Aloft Coning Position (i.e., the crow's nest) on the forward rail at an approximate height of 30 m above the water line.

In 2012, the geoCamera saw its third iteration. Now known as geoCamera 3.0, it is a combination of low-cost, off-the-shelf cameras and custom software designed to capture imagery from a platform equipped with a motion sensor to produce georeferenced maps of the sea surface or, in our case, ice coverage. Weaknesses in previous designs were identified and an updated design was specified and developed for deployment during the HLY1202 cruise on the USCGC *Healy*. The major change was going from a single camera with computer controlled pan, tilt

and zoom capabilities to multiple fixed cameras. On the *Healy*, an existing fixed camera pointing forward has been operating successfully for multiple cruises, so it was decided to augment that existing camera with two similar side-facing fixed cameras. The result has been positive and the system is now capable of automatically capturing raw imagery with associated navigation data and produce geoTIFF images of the ice ready for integration in GIS applications or web-based map server systems. Typical ranges are 1-2 km to either side of the vessel with pixel resolution of between 4 and 7 m.

The success of the geoCamera has led to requests in 2013 for geoCameras to be installed on the new UNOLS R/V *Sikuliaq* and a permanent installation on the icebreaker *Healy*. A next generation geoCamera is being designed for these installations. Higher resolution cameras with more sensitive image sensors will allow as good or better performance as compared to the initial geoCamera installation on the USCGC *Healy*, a much larger ship.



## Semi-Immersive Large Format Tiled Display

The Center's visualization lab previously employed an immersive display to conduct human factors studies regarding perceptual and cognitive issues relating to visualization-assisted marine navigation tasks. This display consisted of a curved front-projection screen with imagery formed via four projectors, producing a total resolution of 4MP. To avoid obscuring the imagery with shadows, users were required to stand eight feet from the screen. At this distance, the vertical field-of-view was 25°, with 32 pixels per degree.

In order to support further human factors experiments and simulations, as well as to provide an immersive large-format display for presentation and collaborative analysis, the Center has designed and developed a new immersive display that was inspired by, and expands upon, Google's Liquid Galaxy system. It provides a significant upgrade to the Center's old display in terms of image quality, immersion, resolution, and field-of-view. By using off-the-shelf LED monitors, image quality and contrast is substantially higher quality than projections, with no restrictions on user position. Thus, the system can be used with the lights on, and users are free to approach the screens as close as necessary for inspection or interaction. The new monitors' increased resolution (over 10MP) provide, at eight feet, a 36° vertical field-of-view with 53 pixels per degree. However, since the user can now stand much closer, vertical field-of-view values in practice are closer to 65°-90°, leading to a much greater sense of immersion within the 3D data space. This new display has a modular design, allowing for rapid adjustability and future expansion. Each panel is free standing, and the angles between them can be adjusted. This permits switching between a fairly flat panoramic display, which is useful for group presentations or collaborative analysis tasks, and a tightly curved surround display, which is useful for highly-immersive simulations (Figure 7-13).

This system has the advantage of driving all the monitors through a single graphics interface that can be reported to the operating system as a single display. Thus, any existing application (e.g., Fledermaus) is able to take full advantage of the high-resolution panoramic display space. Interaction is currently possible with wireless mouse/keyboard, space mouse, or Polhemus electromagnetic sensors (bat). Butkiewicz is currently working on utilizing Microsoft Kinect devices to track

multiple users in front of the display, and allow them to interact with their applications via hand gestures. By tracking the head position of a user, the imagery can be redrawn from the correct corresponding camera locations, such that proper motion parallax cues are presented, leading to greater perception of relative depth. Head tracking will also reduce distraction from the bezels between panels, as the user will be able to see around them simply by moving their head slightly (much as the frames between window panes).

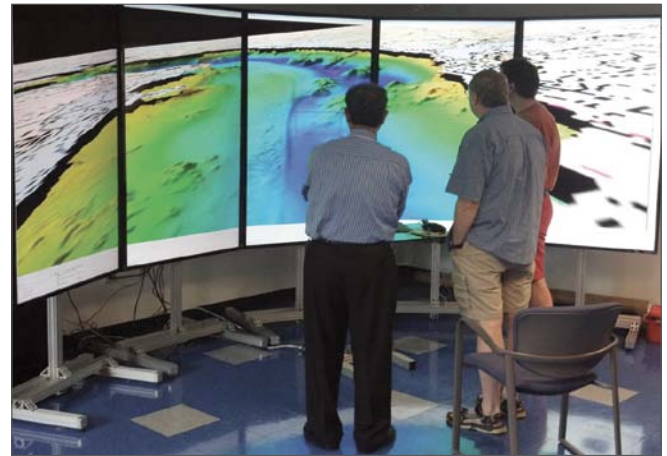

Figure 7-13. The Center's new semi-immersive display in use. Its large-format allows multiple users to examine and analyze data collaboratively in the same space.

## Theme 6 – Chart of the Future

### Developing Innovative Approaches and Concepts for the Electronic Chart of the Future and E-Navigation

The Chart of the Future project is an effort to define the components of the electronic chart of the future by taking advantage of our expertise in visualization, data processing, and navigation. We are taking a two-pronged approach to trying to define the electronic chart of the future. One track of this project is an evolutionary approach to see how additional, non-standard layers (e.g., the navigation surface bathymetric grid, real-time tide information, etc.) can be added to existing electronic charts. This approach requires careful attention to present-day standards and the restrictive constraints of today's electronic charts. This work is being done in conjunction with the standards committees (represented by Center faculty member Lee Alexander) and the electronic chart manufacturers, and is intended to provide short-term solutions for the need to see updated electronic charts. In concert with this evolutionary development, we have a revolutionary development with researchers in our Visualization Lab exploring new paradigms in electronic chart design, unconstrained by existing standards or concepts. This exercise takes full advantage of the psychology-based human-computer interaction expertise of our visualization researchers to explore optimal designs for displays, the role of 3D or 4D flow visualization, stereo, multiple windows, etc. From this research, we hope to establish a new approach to electronic charts that will set the standards for the future. Throughout this project (both the evolutionary and revolutionary efforts), experienced NOAA mariners are playing a key role, ensuring that everything that is developed will be useful and functional.

#### Evolutionary

An Electronic Chart Display Information System (ECDIS) is no longer a static display of primarily chart-related information. Instead, it has evolved into a decision-support system capable of providing predicted, forecast, and real-time information. To do so, Electronic Nautical Chart (ENC) data is being expanded to include both vertical and time dimensions. Using ENC data produced from high-density hydrographic surveys (e.g., multi-beam sonar), a tidal value can be applied to ENC depth areas or contours at arbitrarily fine intervals. The ENC data is not changed, only the display of safe or unsafe water depending on under-keel clearance of the vessel (a parameter set by the ECDIS user) or changes in water levels (e.g., predicted or real-time values).

Lee Alexander is leading our effort to support current ECDIS and ENCs with new data layers through his work with our industrial partners on a prototype "Tide Aware" ENC and his work with U.S. Coast Guard, Canadian Coast Guard, and the International Association of Lighthouse Authorities (IALA), looking at the role that electronic charting will play in the e-Navigation concept of operations. E-Navigation is the harmonized collection, integration, exchange, presentation and analysis of maritime information onboard and ashore by electronic means to enhance berth-to-berth navigation and related services, for safety and security at sea and protection of the marine environment. Most recently, Alexander has been working with Industrial

Partner ESRI to implement procedures developed for assessing the adequacy of hydrographic surveying and nautical charting coverage. This approach, developed for test datasets around Belize and Nigeria (see previous progress reports) uses symbols, warnings and soundings from nautical charts and sailing directions and converts them into hierarchical levels of chart adequacy and "maritime significant areas" class maps. The goal of working with ESRI is to develop this work-flow process using ArcMap and making it readily available to the broader community.

As Chair of the IALA Information Portrayal Working Group, Alexander facilitated a review of existing performance standards for ship-borne and shore-based equipment, systems and services that have been adopted by the International Maritime Organization (IMO), International Hydrographic Organization (IHO), and IALA to determine their compatibility with the e-Navigation concept of operation. Particular attention was given to IMO performance standards on the "Presentation of Navigation-related Information on Ship-borne Displays." Criteria for evaluation will be the "Guiding Principles" recently adopted by IMO for Automatic Information System (AIS) Application-Specific Messages (IMO SN/1/Circ.290). The IALA Guideline on the Shore-side Portrayal Ensuring Harmonization with e-Navigation related Information was completed in September 2013.

Additionally, Alexander is working with NOAA's John Kelley to investigate the process and infrastructure required to broadcast NOS and NWS meteorological and hydrographic information to ship-borne maritime users in major U.S. ports and coastal areas via the Automatic Identification System (AIS) Application Specific Messages. AIS contributes to safety-of-navigation and marine environmental protection by enhancing situational awareness of vessel movements, and by providing navigation-related information in the form of AIS Application Specific Messages (ASMs). This includes meteorological and hydrographic data (met/hydro), dangerous cargos, safety and security zones, recommended routes, status of aids-to-navigation, and other time-sensitive safety information. In U.S. waters, this information will be broadcast from AIS shore stations and received by ship-borne AIS equipment that is installed onboard ocean-going SOLAS vessels. Recently, AISASMs have been identified as a means to achieve key elements of e-Navigation. A review is ongoing related to the data contents/parameters that are currently used to convey NOAA PORTS and nowCoast (met/hydro) information. Recommendations will be provided regarding:

- What PORTS/NowCoast data parameters can be used or need to be modified to conform to the international data standard on AIS ASMs (IMO SN.1/Circ.289).
- The four basic means of displaying NOAA PORTS met/hydro AIS ASMs (alpha-numeric; graph; point, line, or polygon; symbol/ icon) as specified in the new IMO standard for displaying AIS ASMs (IMO SN.1/Circ290).

## Open Navigation Surface

Efforts to standardize formats for the distribution of full-density bathymetric data to be included in ENC's are continuing through the Open Navigation Surface Working Group. Brian Calder serves as the Chair of the Open Navigation Surface Working Group and as a member of its Architecture Review Board. His role is primarily as facilitator, but he also serves as release manager for the library, and keeps the website updated as appropriate. In 2013, Version 1.5.2 was put out as an interim release (the planning meeting was on April 4, with final release was on September 4). This version addresses primarily the stability of the build system, resource versioning, and the use of external libraries. In particular, the ONS has moved to a consolidated build system based on CMake that greatly simplifies the build, removing the Xerces XML parser library, which is massive, but is no longer required due to improvements in the libxml2 library. Version 1.6 is on the horizon, with the development topic list still being completed.

## Right Whale AIS Project

The Right Whale AIS Project that the Center has been supporting for a number of years is aimed at providing Liquid Natural Gas (LNG) carriers real-time input on the presence of right whales in their vicinity through a series of permanent, hydrophone-equipped buoys, a right whale vocalization system, and the transmission of the confirmed presence of a right whale to the vessel via AIS. The Center's role has been the AIS transmission and interface with the electronic chart on board the vessel. Last year an iPhone app, WhaleALERT, was developed to augment existing ship navigation tools

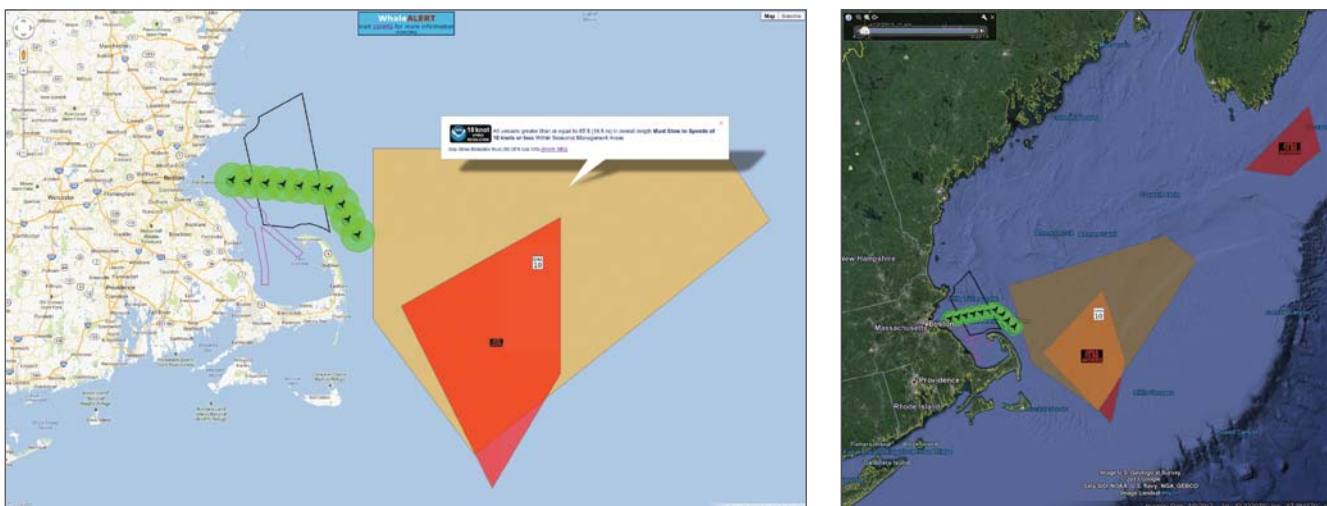

Figure 8-1. Web-based WhaleALERT showing the status of Right Whale Listening Network buoys and various management areas (left). WhaleALERT data as a dynamically updating KML layer in Google Earth (right).



that inform mariners of the safest and most current information to reduce the risk of right whale collisions.

The Center's role is to aggregate buoy data from Cornell University and sightings and Dynamic Management Areas (DMAs) from NOAA and transmit them via both Automatic Identification System and the internet using the IMO Circ. 289 Area Notice message format. For many years, Kurt Schwehr laid the ground work for this project. Last year, Roland Arsenault took over the management of the Center's infrastructure and expanded the system to support DMAs and sightings. To expand the availability of the AIS based notices and to provide a debugging tool while developing and supporting the message transmission, code to display area notices was contributed to OpenCPN, a cross-platform open source chart display application. In 2013, Arsenault developed a web-based WhaleALERT to serve as a cross-platform alternative to the iPad WhaleALERT app and provide the ability to generate KML files so that WhaleAlert data can be viewed dynamically in GoogleEarth (Figure 8-1).

## IHO Compliant Current and Tide Display

As discussed in the VISUALIZATION theme, Center researchers have become heavily involved with the IHO's Surface Current Working Group with the goal of developing an S-100 compliant product specification for the portrayal of tides and currents. To support this effort, Roland Arsenault has been developing approaches for the display of forecast current data using streamlines that can be implemented in a web browser as a layer on top of Google Maps (Figure 8-2). The generation of the streamlines occurs in the browser's Javascript environment allowing both streamline generation

parameters and display parameters to be controlled by the user. A study is being prepared to help select useful parameters for displaying such data as a layer on an ENC and will be used to inform ENC specifications.

## Risk Models for Hydrographic Resurvey Priority Determination and Real-Time Risk Prediction

Many hydrographic offices have difficulties in determining how best to allocate limited resources to the task of resurveying their area of responsibility. Most often, this is done through educated guesswork or in response to user complaints and is a very subjective process. Similarly, there is current international interest in understanding representation of uncertainty in some form for charted data and to provide a mechanism to use this to support decision-making for underway transit.

Previous work on risk-base models of uncertainty for hydrographic applications (Calder) and statistical analysis of AIS traffic data (Calder and Schwehr) indicated that it might be possible to use a combination of these techniques to build models that reflect the residual risk to the ship for undertaking a transit through a specific area of the chart, computed based on knowledge of the ship's configuration (maneuvering capability, dimensions and draft, etc.), the local environment (waves and currents, wind, geology, etc.) and an understanding of the source data in the area (provenance, age, technology, etc.), with calibration coming, in part, from the AIS data.

Due to interest in these techniques from NOAA, the IHO and UKHO, Calder has begun a project to investigate the use of risk models to prioritize re-survey areas within a chart portfolio. Using the UKHO domestic portfolio as an example dataset, the goal is to assess the traffic usage patterns in each area, along with the climatic conditions and chart source data in order to provide a relative risk measure for traffic in each area so that re-survey resources can be prioritized according to risk. Development within this reporting period has been primarily theoretical, considering the questions of data availability and calibration, and what measures of risk would be appropriate (e.g., what should the balance be between traffic observed and the potential for use of other areas in an emergency?).

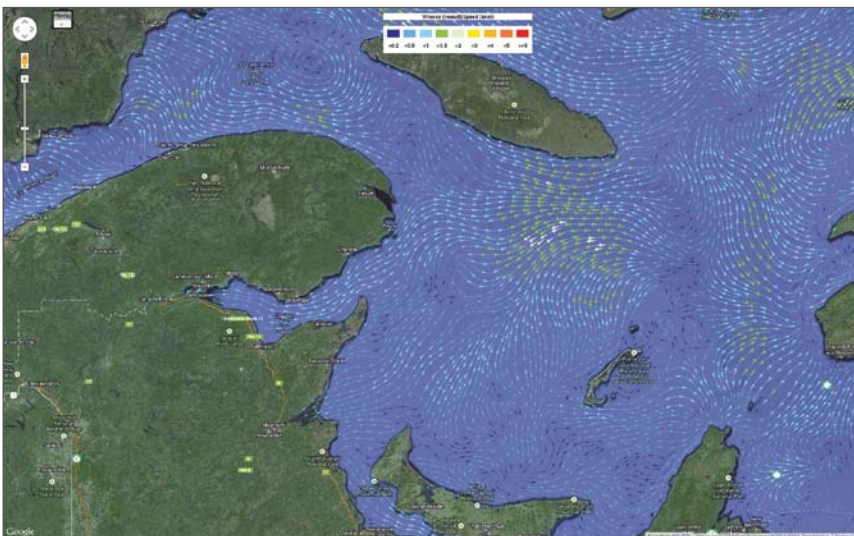

Figure 8-2. Current forecast for the Gulf of Saint Lawrence displayed as streamlines in Google Maps.

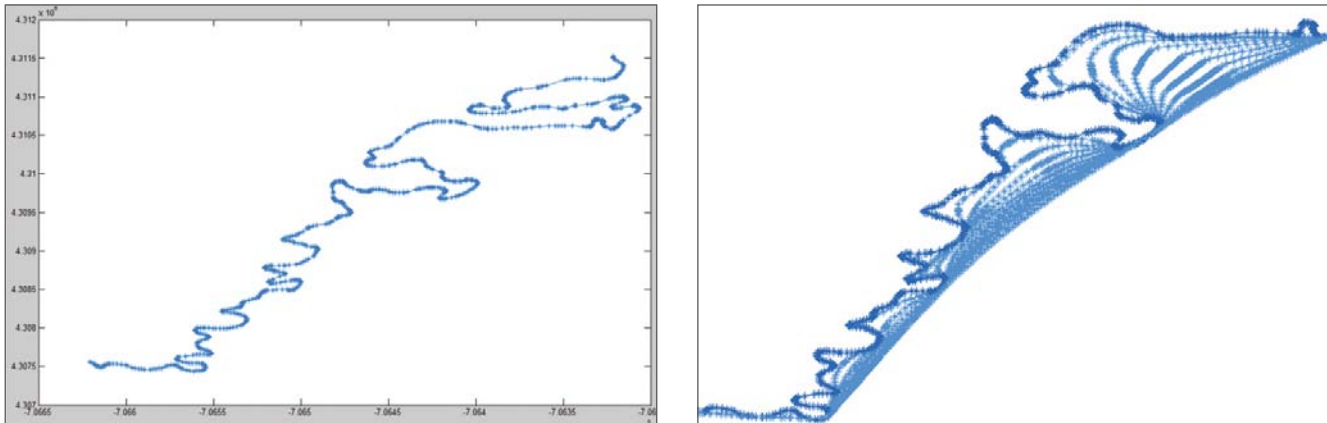

Figure 8-3. Original contour (*left*) and generalized contour showing the interim steps (*right*).

### Automated Approaches to Data Generalization for Chart Production

Data collected using modern survey methods is typically much denser than can be conveyed with clarity on a traditional charting product. Although we are investigating new methods to augment or replace those products, they are still the predominant form in which this data is conveyed to users and, therefore, we have been investigating methods to aid in clarity of representation.

The conventional approach to the clarity problem is one of generalization, where less important detail is suppressed from the data in order for the critical data to be clearly displayed. Often, changes in scale mean that soundings or contours are modified, with the constraint that they must always depict the area as at least as shallow as the shallowest area present (i.e., depths are always shoal-biased and contours always move offshore). Most approaches to this have been subjective and based on hand-edited contours (even if the contours were originally machine generated), making it time consuming and error prone.

Graduate student Dandan Miao, under the supervision of Brian Calder, has therefore been focusing on the contour generalization part of the problem. The aim is to develop methods that allow contours to generalize to any given applications scale from a high-resolution original set, but to do so in a way that preserves the hydrographic constraints on generalization, and ensures that the contours always remain consistent. That is, they interact with each other—and potentially other things on the chart—so that they maintain a minimum separation, always stay in the appropriate depth order, never overlap, and aggregate like depth contours when they would become too small to portray individually, for example. The end-state goal, for which this work

is the first stage, is to have a semi-automated environment where the user controls the parameters that drive the generalization, adjusting them to generate results in harmony with practical requirements and aesthetic preferences, with the algorithms doing the computational work of generalization behind the scenes.

The technique developed (called the B-Spline Snake method) generates smooth, simplified and shoal-biased polyline contours. The approach mathematically moves the curve to its appropriate position by setting a proper energy equation. The B-Spline method is used here to decrease the total number of vertices on the contour curve and the snake method is used here to fulfill the smoothing and shoal-bias goal of contour generalization. By setting certain internal and external energy terms, and solving the energy equation, the contour curve can automatically and gradually deform to a new contour that has been moved to the deeper side of the original curve, and also be significantly simplified and smoothed. The B-Spline Snake method has been used in contour generalization before, but the method used here is refined numerically and the solution has been modified so that the contour can deform without any spikes or any numerically unstable errors.

These algorithms have been tested on five test cases: 1) a simple polyline contour; 2) a polyline contour and a set of polygon contours; 3) a set of simple polygon contours; 4) a set of concentric polygon contours, and; 5) a long, complicated polyline and a set of polygon contours. These five test cases contain most of the basic contour feature combinations that might occur on charts. For different test cases, the input features are different and thus different workflows are designed to use the algorithms properly. The workflows can be expanded to accommodate more complicated and larger numbers of contours and with computational optimization, should be applicable to real chart data.



## Revolutionary

Within the context of the “revolutionary” effort, Colin Ware, Tom Butkiewicz, Matt Plumlee, Briana Sullivan and Roland Arsenault have been developing specific applications for the Chart of the Future. Many of these capabilities were described in past progress reports; we will only highlight 2013 developments here.

### Local Notice to Mariners—Chart Update Mashup (ChUM)

The Local Notice to Mariners (LNM) contains information relating to navigational aids, bridges, construction, local events, and at least 11 other related topics. It is a rich and useful resource for all types of mariners. One of the biggest challenges in working with the LNM is the form in which it is presented to mariners (either as a PDF file or as online tables). While the PDF LNM updates and online tables (and the Coast Pilot) all provide essential information to the mariner, they can be cumbersome to use. This was clearly demonstrated by a survey on LNM use conducted in 2011 by the Alliance for Safe Navigation that showed that 70 percent of the boaters responding said that they were aware of LNMs but they did not download or use them.

Of the two sources of LNM available, the PDF version is more difficult to read than the table view (provided by OCS) of the same information. Since the OCS table allows for filtering on a specific chart and viewing historical data, it greatly reduces the overload of information shown, but offers no visual spatial context for the information. Each item in the table is geo-referenced, which means that displaying it within the context of a nautical chart is the logical way to present it, but the mariner currently would need to manually plot each point on a nautical chart. The fundamental drawback to both the PDF and the table version of the chart corrections is that the user cannot interact with them.

To address these issues, Briana Sullivan has developed the Chart Update Mashup (ChUM), a small, specialized mashup application designed to work with Google Maps. ChUM was created to effectively display the chart catalog and nautical charts in a geo-referenced environment, along with the critical corrections to the chart and the Coast Pilot with geo-referenced links. ChUM is a web application that uses and combines data, presentation, or functionality from two or more sources to create a new service. To create ChUM,

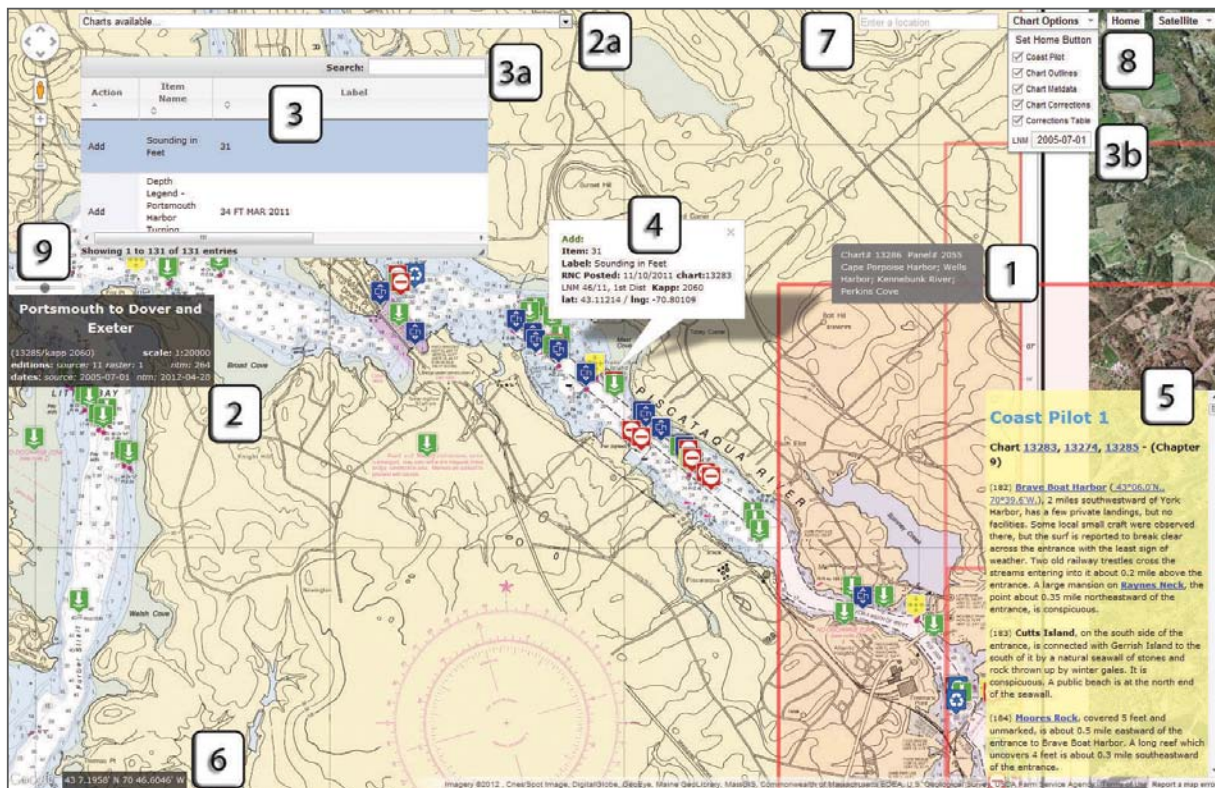

Figure 8-4. Overview of ChUM capabilities. The numbers on the figure refer to items in list above.



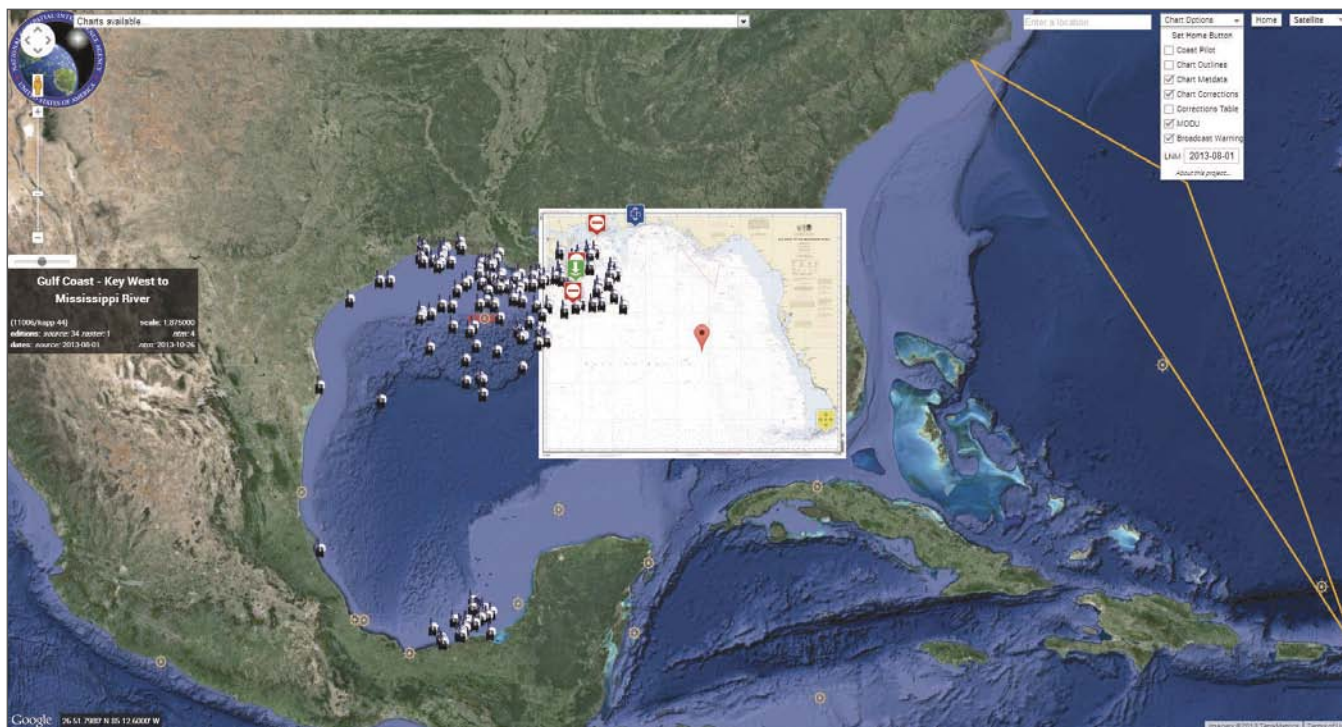

Figure 8-5. Navy version of ChUM with MODUs and Broadcast Notices.

Google style controls, the Nautical Charts API, Google Maps API v3, and the Nautical Charts APIUI have been integrated to seamlessly work with each other.

The result is the integration of NOAA nautical charts, the NOAA chart catalog, critical chart corrections from the LNM and the Coast Pilot in a georeferenced web-based environment. ChUM features include (see Figure 8-4):

1. Integration of NOAA chart catalogs
2. Integration of NOAA nautical charts
  - a. Ability to filter charts depending on viewport
3. Integration of critical chart corrections from OCS as a dynamic/interactive table
  - a. With the ability to filter data
  - b. With the ability to view historical data
4. Integration of critical chart corrections as geo-referenced markers within the context of the chart
5. Integration of Coast Pilot with Geo-coded places
6. Geo-referenced environment
7. Ability to search place names
8. Ability to save a location bookmark
9. Ability to set the chart transparency

ChUM can assist with quality assurance and quality control for OCS/USCG internal use as well as help to raise awareness of the numerous changes made to a nautical chart, helping the mariner to effortlessly visualize corrections with an intuitive interface in a web-based geo-referenced environment. This tool is publicly accessible at: <http://vislabccom.unh.edu/~briana/ncapiui-v2/>.

Recent updates to ChUM include adding MODUs (mobile oil drilling units) and Broadcast Notices for version requested by the USN (Figure 8-5). Sullivan has also been working on adding other information from NGA to the Navy version of the mashup.

Finally, ChUM is also being reworked into a mobile web product that utilizes the NOAA Seamless Chart Server and jQuery Mobile user interface. In the mobile version, all notices will be displayed for the entire viewing area (instead of just for a selected chart), will show the user's position on the chart, and give an option to view a list of the chart updates without the map.

## Theme 7 – Law of the Sea

### Being National Leaders in the Planning, Acquisition, Processing, Analysis and Interpretation of Bathymetric Data Collected in Support of a Potential Submission by the U.S. for an Extended Continental Shelf Under Article 76 of the United Nations Convention on the Law of the Sea

Growing recognition that implementation of United Nations Convention on the Law of the Sea (UNCLOS) Article 76 could confer sovereign rights to resources over large areas of the seabed beyond our current 200 nautical mile (nm) Exclusive Economic Zone has renewed interest in the potential for U.S. accession to the Law of the Sea Treaty. In this context, Congress (through NOAA) funded the Center to evaluate the content and completeness of the nation's bathymetric and geophysical data holdings in areas surrounding the nation's EEZ with emphasis on determining their usefulness for substantiating the extension of resource or other national jurisdictions beyond the present 200 nm limit. This report was submitted to Congress on 31 May 2002.

Following up on the recommendations made in the UNH study, the Center has been funded (through NOAA) to collect new multibeam sonar (MBES) data in support of a potential claim under UNCLOS Article 76. Mapping efforts started in 2003 and since then the Center has collected more than two million square kilometers of new high-resolution multibeam sonar data on 24 cruises, including six in the Arctic, six in the Atlantic, one in the Gulf of Mexico, one in the Bering Sea, two in the Gulf of Alaska, two on the Necker Ridge area off Hawaii, one off Kingman Reef and Palmyra Atoll, four in the Marianas region, and one on Mendocino Fracture Zone (Figure 9-1). Summaries of each of these cruises can be found in previous annual reports and detailed descriptions and access to the data and derivative products can be found at [http://www.ccom.unh.edu/law\\_of\\_the\\_sea.html](http://www.ccom.unh.edu/law_of_the_sea.html). The raw data and derived grids are also provided to the National Geophysical Data Center and other public repositories within months of data collection and will provide a wealth of information for scientific studies for years to come.

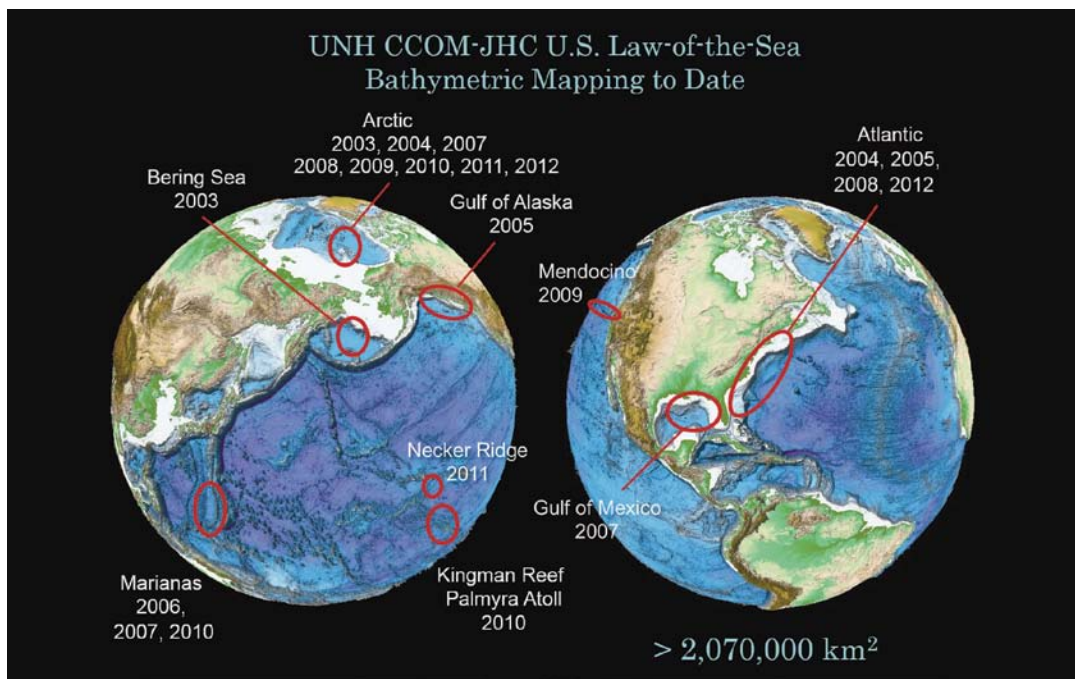

Figure 9-1. Summary of Law of the Sea multibeam sonar surveys collected by the Joint Hydrographic Center to date. More than 2.07 million km<sup>2</sup> of data has been collected.





Figure 9-2. New Arc interface for Law of the Sea data (Arctic holdings in this example). Data is now served as a single grid (rather than subareas) in several formats (ESRI, Fledermaus, ASCII xyz).

## 2013 Law of the Sea Activities

Funding constraints led to no ECS cruises in 2013 and thus there are no sea-going activities to report. Nonetheless, Center personnel have continued to play an active and important role in managing and archiving the Law of the Sea data we have collected, as well as analyzing data and participating in a range of Law of the Sea Task Force activities. Paul Johnson has done much to upgrade our database capabilities (see DATA MANAGEMENT section) and has worked with Jim Gardner to add data and capabilities to our Law of the Sea database and website. Bathymetry and backscatter grids for the most recent Arctic and Atlantic ECS were initially made available during the fall and winter of 2012 upon completion of the field programs and processing of their data. However, during late 2012 and early 2013, Gardner reprocessed and revalidated portions of these datasets, then Johnson generated new metadata for each data product and re-bundled them for release. Historically, the Atlantic Law of the Sea data had been subdivided into four areas (the Far North, North, South, and Far South areas). As two of the sub-areas were being updated during this time, it was decided to generate a single grid for the entire region (Figure 9-2). This allowed for much simpler interaction with the data, as users could now work with

a single grid instead of four and, just as importantly, it meant that management of the data was easier, as a single grid could now be served in three formats (ESRI, Fledermaus SD, and ASCII) instead of four grids in three formats. As part of the process of improving data products, Johnson began to validate each of the Law of the Sea derivative products being served off of the website. This review looked at the completeness of the XML metadata, examined items included with the distribution, embedded metadata directly into GIS files, and generated updated maps of the products.

Gardner, Mayer and Andy Armstrong have also spent much time analyzing ECS data, participating in ECS Task Force, Working Group, Integrated Regional Team and other Law of the Sea-related meetings including a three-day U.S. State Department workshop in Washington, D.C. in April to critique a pilot submission for the U.S. Western Gulf of Mexico assembled by the GOM IRT. This was the first attempt to compile a complete U.S. ECS package that would resemble a submission to the Commission on the Limits of the Continental Shelf.

Gardner has been involved with seven of the eight IRTs and has worked closely with the data managers to ensure that all bathymetric data holdings are available to IRTs and to provide detailed regional analyses for areas of particular concern to the Task Force. These areas include the Necker Ridge (Figure 9-3), the northern Line Islands Ridge in the vicinity of Kingman Reef-Palmyra Atoll (Figure 9-4), and the Mendocino Ridge (Figure 9-5).

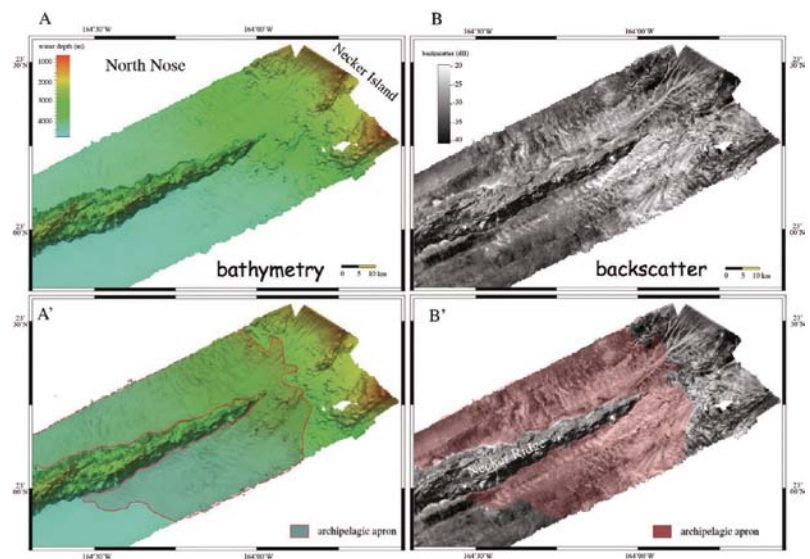

Figure 9-3. Map view of multibeam bathymetry (A and A') and backscatter (B and B') of the NE nose of Necker Ridge. Figures A and B are of the data and Figs. A' and B' show the extent of the archipelagic apron.



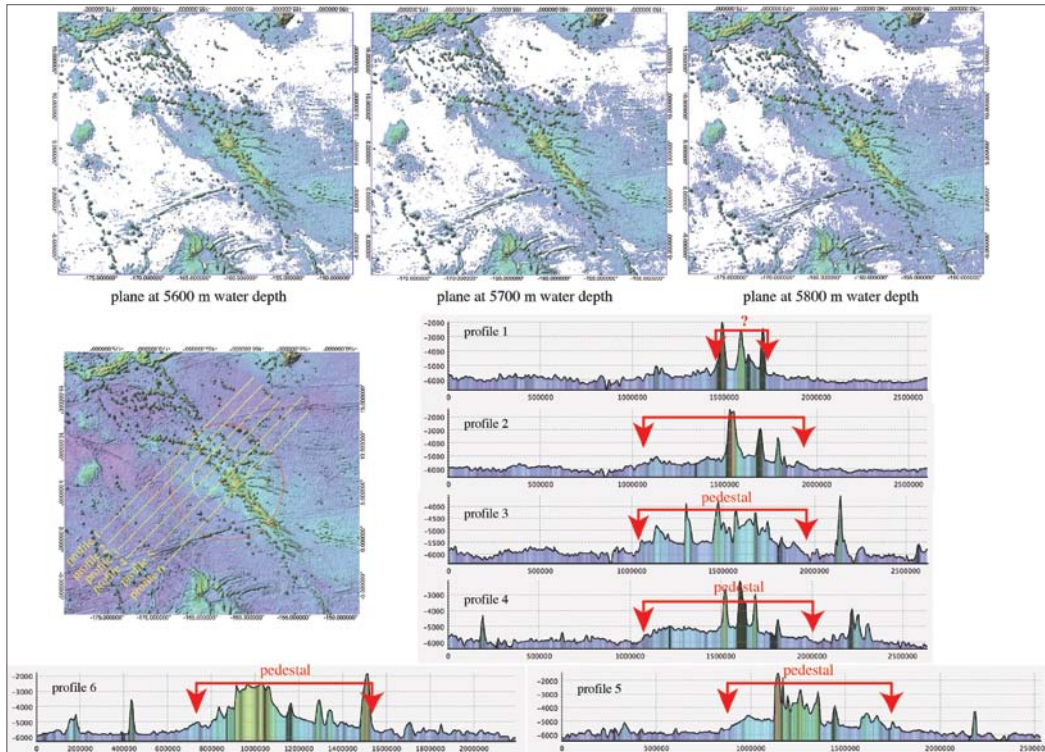

Figure 9-4. Top three panels are plane slices through the bathymetry showing white areas deeper than 5000, 5700, and 5800 m. Profiles are from SW to NE across the Line Island Ridge and adjacent deep abyssal seafloor. The extent of the width of the pedestal that the Line Island Ridge is built upon is shown the red lines.

## Extended Use of ECS Data

Demonstrating the value of the ECS multibeam sonar data beyond the establishment of an extended continental shelf, Jim Gardner spent much of 2013 involved in writing peer-reviewed journal articles and a USGS Open-File Report. Gardner is senior author of three peer-reviewed papers and co-author on the other two. Two of Gardner’s senior-authored papers and the USGS Open-File Report utilize data collected under the Law of the Sea program. The fourth paper involves data Jim collected several years ago in the Gulf of Mexico.

The first paper, (Gardner, J.V., Calder, B.R., and Malik, M., 2013, *Geomorphometry and processes that built Necker Ridge, central North Pacific Ocean*. *Marine Geology*, v. 346, p. 310-325) was written, submitted, reviewed, revised and finally published all in 2013. The paper describes the quantitative geomorphology (geomorphometry) of Necker Ridge in the central Pacific Ocean as derived from new ECS multibeam bathymetry and backscatter data. Although the ridge was known to exist, its origin, mode of formation and subsequent modification by seafloor processes had never been investigated before the ECS multibeam surveys.

The second paper (Gardner, J.V., Armstrong, A.A., Calder, B.R. and Beaudoin, J., 2013), *So, how deep is the Mariana Trench? Marine Geodesy*, DOI:10.1080/01490419.2013.837849) was written in collaboration with Andrew Armstrong, Brian Calder and Jonathan Beaudoin. The paper reviews all of the attempts to determine the deepest depth of Challenger Deep in the Mariana Trench, and then describes a detailed analysis of ECS multibeam bathymetry collected there to accurately determine the deepest depth. The deepest depth was determined to be  $10,985 \pm 25$ m and located at  $11.329903^\circ\text{N}/142.199305^\circ\text{E}$ . The paper was written, submitted, reviewed, revised and resubmitted and finally published in 2013.

The Open File Report (Andrews, B.D., Chaytor, J.D., ten Brink, Uri S., Brothers, D.S. and Gardner, J.V., 2013), *Bathymetric terrain model of the Atlantic margin for marine geological investigations*. U.S. Geological Survey Open-File Report 2012-1266, <http://dx.doi.org/10.3133/ofr20121266>, is a compilation of mostly Center ECS multibeam bathymetry and a very minor amount of USGS-collected bathymetry. Jim was includ-

ed as an author because he collected and processed more than 98% of the data used in this report.

### Use of ECS Data for Broad-Scale Habitat Mapping

Graduate student Derek Sowers, under the supervision of Larry Mayer, has been investigating the potential of using the data collected in support of ECS studies for broad-scale habitat mapping. His initial focus has been the ECS data collected along the Atlantic Margin, where large amounts of ancillary data (images, core samples, ecological studies) already exist. These datasets include multibeam sonar from eight Center cruises conducted for the U.S. Atlantic ECS work and six exploration cruises of the Northeast Atlantic canyons by the NOAA vessel *Okeanos Explorer*. Other datasets evaluated include biological samples, video, and photos previously collected for the region and archived in data repositories such as the usSEABED database, GeoMapApp, and the National Geodatabase of Deep Sea Coral Observations. A flow chart describing the approach is presented in Figure 9-6. The effort will attempt to use the multibeam bathymetry and backscatter data collected on ECS (and other cruises)

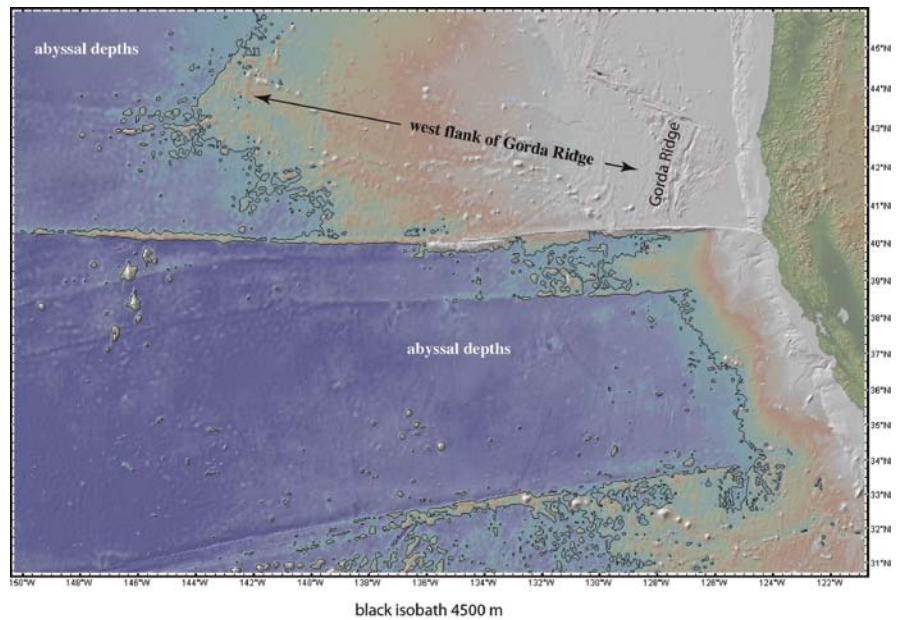

Figure 9-5. GMRT bathymetry of eastern Pacific region of Mendocino Ridge with 4500-m isobath in black. Note the 1 km difference in depth of the seafloor north vs. south of Mendocino Ridge. Abyssal depths (>5000 m) are found immediately south of Mendocino Ridge seafloor depths to the north reflect the young oceanic crust of Gorda Ridge.

along with the ancillary data sets to see if the Atlantic Margin can be characterized using NOAA's Coastal and Marine Ecological Classification Standard (CMECS) (Figure 9-6). Derek has presented an overview of his project to NOAA habitat specialists in Silver Springs and received enthusiastic support for this effort.

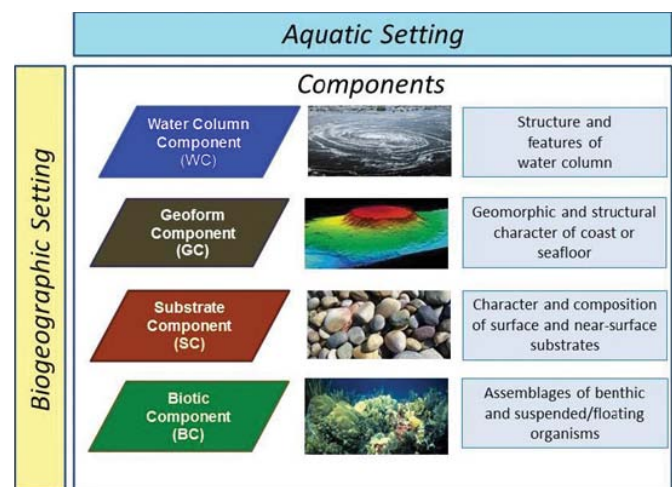
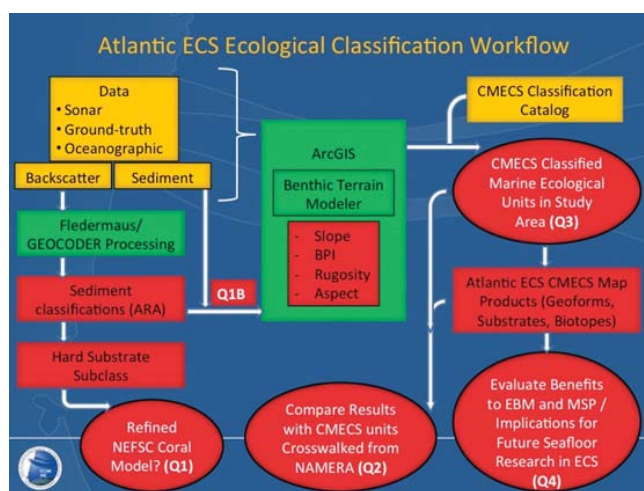

Figure 9-7. Top three panels are plane slices through the bathymetry showing white areas deeper than 5000, 5700, and 5800 m. Profiles are from SW to NE across the Line Island Ridge and adjacent deep abyssal seafloor. The extent of the width of the pedestal that the Line Island Ridge is built upon is shown the red lines.

## Outreach

In addition to our research efforts, we also recognize the interest that the public takes our work and our responsibility to explain the importance of what we do to those who ultimately fund our work. We also recognize the importance of engaging young people in our activities to ensure that we will have a steady stream of highly skilled workers in the field. To this end, we have been upgrading our web presence and expanding our outreach activities and staff (Tara Hicks-Johnson, an experienced outreach specialist joined our staff in 2011). Tara now coordinates Center activities with UNH Media Relations to coordinate Center-related releases and media events and has begun working with NOAA media personnel in preparing releases featuring Center faculty. The Center continues to attract significant media attention. A partial list of media reports on CCOM activities is listed below.

Jan. 17, 2013	Scientists Develop New Use for Sonar Technology During Deepwater Horizon Spill	<i>UNH Today</i>
Jan. 23, 2013	Research Profile: Larry Mayer – Picturing the Arctic Ocean Floor	<i>UNH Campus Journal</i>
Apr. 22, 2013	170 Delegates Attend FEMME 2013	<i>Hydro International</i>
Apr. 25, 2013	Kongsberg: 170 Delegates Attend FEMME 2013 (Norway)	<i>Dredging Today</i>
Jun. 13, 2013	Ocean Mapping	<i>NH Chronicle</i>
Jul. 11, 2013	Committee Chaired by UNH Prof Releases Final Gulf of Mexico Restoration Report	<i>UNH Campus Journal</i>
Jul. 17, 2013	Ocean Explorers Here to Map Future Program	<i>The Gazette</i>
Jul. 18, 2013	In Long Beach, drafting a blueprint for exploring the world's oceans	<i>Los Angeles Times</i>
Jul. 19, 2013	Government and Tech Companies Plan Exploration of Oceans	<i>Wall Street Journal</i>
Jul. 19, 2013	Aquarium of the Pacific hosts 2020 Ocean Exploration Forum and Explorer's Day	<i>Examiner.com</i>
Jul. 25, 2013	Committee chaired by UNH prof releases final Gulf of Mexico Restoration report	<i>Foster's Daily Democrat</i>
Aug. 9, 2013	Ship has mission to map ocean floor	WMUR
Aug. 10, 2013	NOAA vessel to map the ocean floor along East Coast	<i>Seacoastonline.com</i>
Aug. 10, 2013	NH becomes home port of newest NOAA mapping vessel	<i>Boston Globe</i>
Aug. 10, 2013	They came to see the ocean floor: Ship to update nautical maps of area seabed	<i>Foster's Daily Democrat</i>
Sep. 9, 2013	UNH launches marine science and ocean engineering school	<i>Seacoast Online</i>
Sep. 9, 2013	UNH starts school of marine science	WCAX
Sep. 9, 2013	UNH starts school of marine science	WFTV
Sep. 9, 2013	UNH starts school of marine science	<i>SeattlePI</i>
Sep. 9, 2013	UNH Dives Into Marine Science	NHPR
Sep. 9, 2013	UNH starts school of marine science	<i>Foster's Daily Democrat</i>
Sep. 9, 2013	UNH starts school of marine science	<i>Boston Globe</i>
Sep. 9, 2013	UNH starts school of marine science	NECN



Sep. 12, 2013	UNH launches School of Marine Science and Ocean Engineering	<i>Foster's Daily Democrat</i>
Sep. 14, 2013	Dive into marine science at ocean day	<i>Foster's Daily Democrat</i>
Sep. 20, 2013	UNH welcomes new school to campus	<i>The New Hampshire</i>
Sep. 22, 2013	NH students educated, inspired during Ocean Discovery Day at UNH	<i>Union Leader</i>
Sep. 24, 2013	Crowds Gather for Ocean Discovery Day at UNH	<i>The New Hampshire</i>
Sep. 29, 2013	Ocean Discovery Day	<i>Foster's Daily Democrat</i>
Sep. 29, 2013	Telepresence at UNH Connects Researchers to Offshore Ships	<i>The New Hampshire</i>
Oct. 13, 2013	Humpback Whale Crittercam Video Reveals Bottom-Feeding Activity	<i>National Geographic</i>
Oct. 13, 2013	Study Links Warmer Water Temperatures to Greater Levels of Mercury in Fish	<i>The Washington Post</i>
Oct. 29, 2013	Research Confirms Bottom-Feeding Behavior of Humpback Whales	<i>UNH Campus Journal</i>
Oct. 30, 2013	Humpback Whales Are Primarily Bottom Feeders	<i>Nature World News</i>

## Outreach Events

The facilities at the Center provide a wonderful opportunity to engage students and the public in the types of research that we do here. In 2013, the Center hosted a number of local schools and community groups, including a group of regional guidance counselors, 40 students from Portsmouth Middle School, 120 students from Barrington Middle School, 160 students from Oyster River Middle School, 20 students from the Claremont, NH 4H robotics group, 35 students from the Learning Skills Academy, 60 students participating in UNH Tech Camp, 15 campers attending the SeaPerch camps at the Seacoast Science Center, 60 students from the Computer Science department, 80 students from the HERO program from Washington DC, and various homeschool associations, 4H STEM groups and academic leaders.

We have also working hard to attract top-notch students to the program by making the activities of the Center known at appropriate venues including the American Geophysical Union Fall Meeting (attended by more than 22,000 people) in San Francisco where both a UNH booth in the academic showcase of the exhibitors hall (Figure 10-1) and an alumni event were organized and well attended.

Several large and specialized events were organized by the Center outreach team, including SeaPerch ROV events and the annual UNH Ocean Discovery Days event. Throughout the year, the Center has been working with the Portsmouth Naval Shipyard (PNS) and UNH Cooperative Extension to host participating schools and community groups that have built SeaPerch ROVs and wish to test them in our facilities. The interest in these ROVs has been so great that PNS and the Center started the Seacoast SeaPerch Regional Competition in 2012.



Figure 10-1. Tom Butkiewicz demonstrates interactive 4-D flow visualization at the Center both at the 2013 AGU meeting.

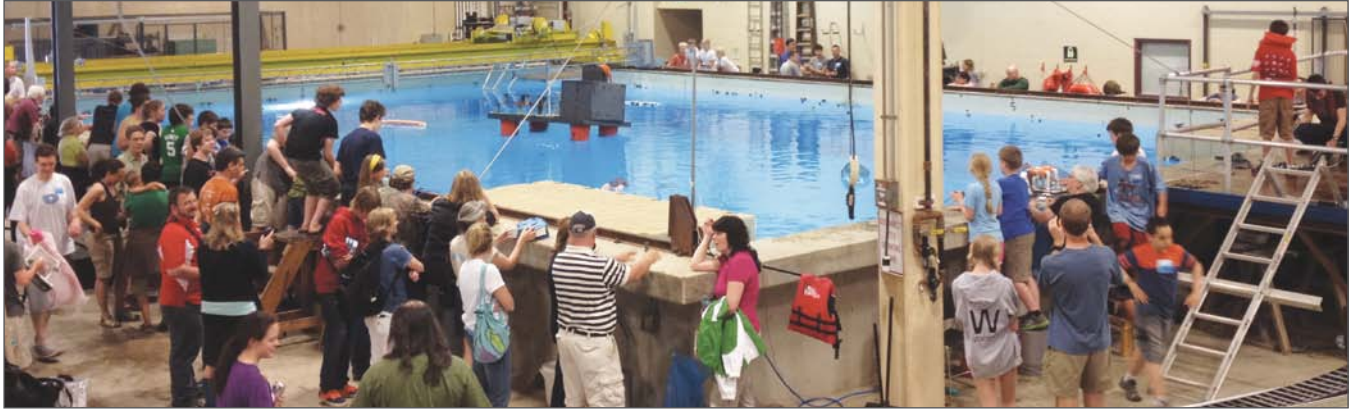

Figure 10-2. Teams prepare for the collapse of an “oil-rig” and subsequent spill that they will be charged to clean up using the ROVs they built themselves.

The second annual UNH Seacoast SeaPerch Competition was held Saturday, May 11 on the UNH campus. Seventeen teams from New Hampshire and Maine schools and community groups competed in this challenge using ROVs that they built themselves. There were two events in the morning competition, an obstacle course and a salvage operation. In a timed obstacle course event, teams had to maneuver their ROVs through a series of underwater hoops, then trace their steps back. In the salvage operation, teams had to remove “debris” in the form of weighted buckets from the bottom of the pool, then retrieve them. In the afternoon, all teams participated in an engineering challenge that involved cleaning up an oil spill from a simulated exploding oil-rig (Figure 10-2).

A second major outreach event at the Center was UNH’s Ocean Discovery Days, an annual two-day event held both at the Chase Ocean Engineering Lab on campus and at the Judd Gregg Marine Research Facility in New Castle, NH. On Friday, September 20th, more than 1,000 students from school groups and homeschool associations from all over New Hampshire came to visit our facilities and learn about the exciting research

happening at the Center. Activities and demonstrations for all ages highlighted research on acoustics, ocean mapping, ROVs, lidar, and ocean visualization.

Students and the public were able to tour the engineering tanks in our High Bay, see videos of the seafloor in our Telepresence room, and try their hand at mapping the ocean floor. Our visualization team showed off their interactive weather map and ocean visualization tools. A highlight was a new interactive activity, a 3D augmented reality sandbox (Figure 10-3) where students can change the shape of the “seafloor” in a sandbox and see a real-time digital terrain model adjust to the changes. The event continued on Saturday, September the 21st, with an open house that included tours of our Marine Facility in New Castle, NH, and a homeporting celebration welcoming the NOAA Vessel *Ferdinand R. Hassler* to New Hampshire. Ocean Discovery Days is a joint outreach event run through the Center, the UNH Marine Program, and the New Hampshire Sea Grant office, and relies on faculty, staff and student volunteers from UNH and volunteers from UNH Marine Docent program.

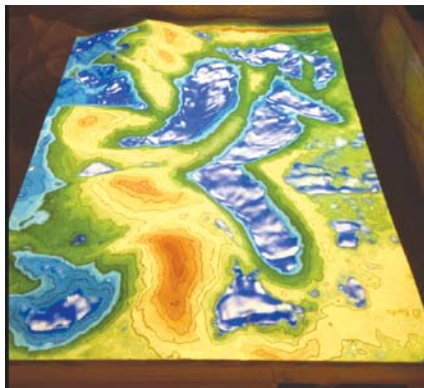

Figure 10-3. Augmented reality sandbox—built after a design provided by UC Davis researchers (<http://idav.ucdavis.edu/~okreylos/ResDev/Sandbox>).



## Website Upgrades and Other Activities

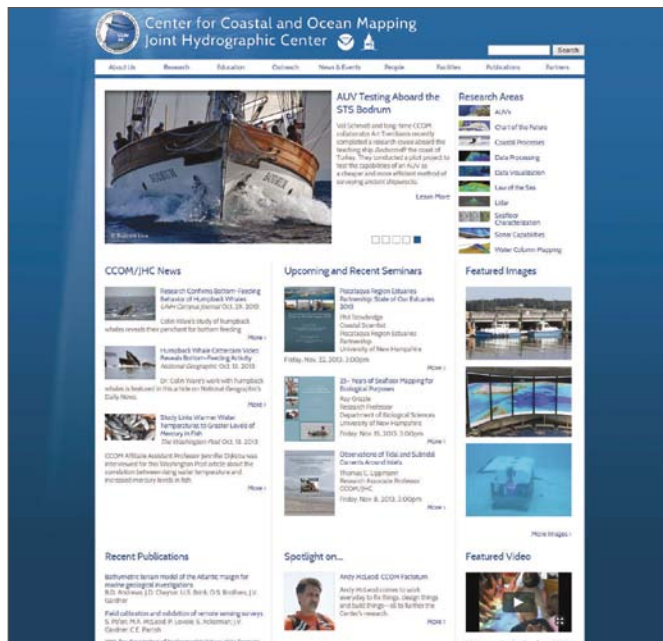

Figure 10-4. The home page of the Center's website.

### Website

Colleen Mitchell and Les Peabody took the lead in 2011 on a complete redesign of the Center website. The graphic design, navigation and overall feel have been changed to reflect a more modern design and are implemented using Drupal (an extensible management system). The redesign of the Center's website culminated in the public launch of the new site in late March 2012. With the departure of Lester Peabody, who was responsible for coding the site in Drupal, we have contracted with UNH's Office of Research Computing and Instrumentation (RCI) to continue making refinements and to add new modules, such as image and video galleries. The consultants at RCI have been concentrating on CCOM's intranet and progress reporting system but we hope to bring their attention to bear on the website in the coming year. In the meantime, Colleen Mitchell, who manages the website, continues to develop content working with Data Manager Paul Johnson to develop sections that feature photo galleries, work products, and interactive maps of data collections.

The website is dynamic with new publications, seminar announcements, news items, and people pages. The home page is continually updated with newly featured images and videos, slides, publications, and news.

In 2013, the website received 41,329 visits from 25,374 unique visitors. 59.8% of those were first time visits. The average visit lasted 3 minutes and 14 seconds. At 59.7%, more than half of the visits originated in the U.S., however, the website has been visited by people from nearly every country in the world.

### Flickr

In addition to events, news articles and publications, the home page also contains featured images and featured videos. The images draw from the Center's Flickr photostream (Figure 10-5) and the videos draw from the Center's Vimeo channel. Flickr underwent an unfortunate redesign this year and we are considering alternative venues to host our images.

In the meantime, the featured images on our home page continue to open in Flickr where a caption provides context for the image and a link back to an appropriate place on the Center's website—a research area, a seminar, a publication, etc. There are currently 1,735 images in the Center's photostream, [http://www.flickr.com/photos/ccom\\_jhc](http://www.flickr.com/photos/ccom_jhc). Since August 2009, when the account was created, these images have received a total of 91,452 views.



Figure 10-5. Example of the Center's Flickr content.



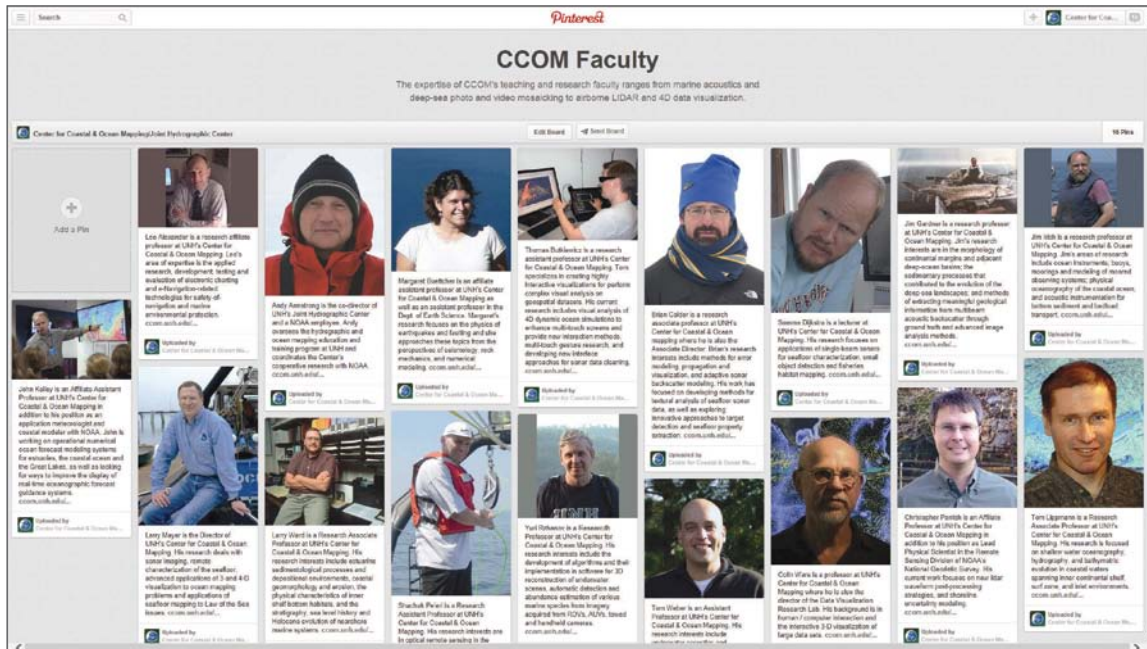

Figure 10-6. Faculty look book on the Center's Pinterest page.

## Pinterest

Colleen recently created a Pinterest page for the Center. She has started with a "pin board" that serves as a look book for the faculty (Figure 10-6). She plans to create boards for the facilities and field-work as well. Pinterest serves as another social media outlet to enhance the Center's digital presence, particularly in reference to attracting graduate students.

## Vimeo

The Center's videos are hosted by Vimeo, <http://vimeo.com/ccomjhc>. There are currently 56 videos in the Center's catalog (Figure 10-7). Some of these videos are short clips, such as a sampling of the WindVis Weather Display or a quick underwater tour of the SeaPerch competition's salvage operation course. Other videos are full-length recordings of our seminar series. In addition to broadcasting the seminars as webinars, the talks are recorded—as long as the speaker is amenable.

In 2013, the Center's videos were played 2,391 times. The most popular video in 2013 was "Mariana Trench Fly Through," which was created by Jim Gardner and has been a featured video on the website.

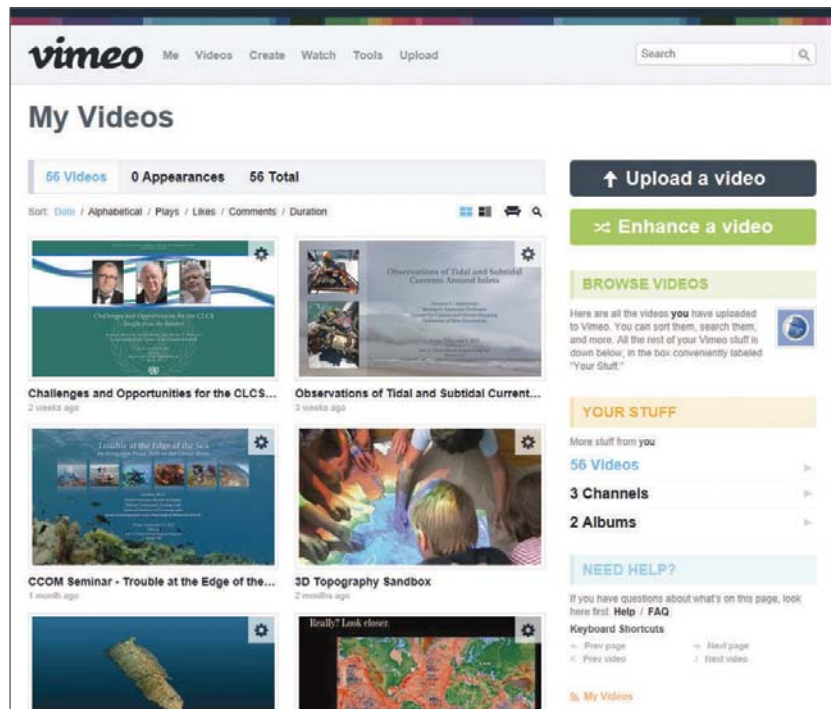

Figure 10-7. The Center's Vimeo page.

## Seminar Series

After a slow start last winter due to inclement weather and illness, the 2013 seminar series rebounded strongly with a total of 28 seminars. Two of these seminars were master’s thesis defenses; all others were presented by Center researchers or experts from industry and academia. In April, renowned oceanographer John Delaney gave a special seminar that garnered so much interest, it was held in a large auditorium on campus to accommodate the size of the audience. A list of the seminars can be found in Appendix E.

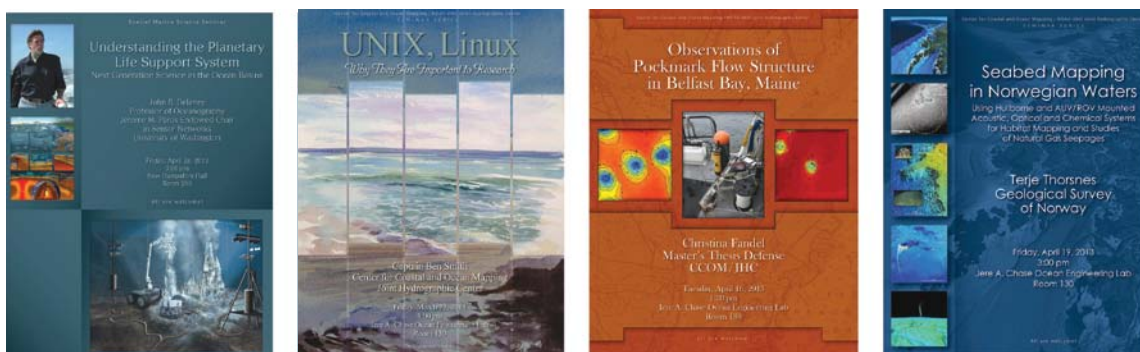

Figure 10-8. A sample of seminar announcements for the 2013 season.

## Facebook

The Center’s Facebook page (Figure 10-9) mirrors the website and provides a less formal venue for posting Center news, announcements, videos, and photos and provides an easy way for alumni to stay involved with the Center. The page currently has 299 “likes.” Colleen Mitchell, who administers the page, creates posts that are interesting and informative, carefully monitoring the frequency of posts so they do not become tiresome. It is very rare that anyone resigns from the page. Posts are frequently “liked” or shared so that they appear in individuals’ news feeds, increasing exposure significantly. Like the website, the Center’s Facebook page is vibrant and content-rich and the two sites work in tandem to increase the Center’s on-line presence.



Figure 10-9. The Center's Facebook page.

### Partnerships and Ancillary Programs

One of the goals of the Joint Hydrographic Center is, through its partner organization the Center for Coastal and Ocean Mapping, to establish collaborative arrangements with the private sector and other government organizations. Our involvement with Tyco has been instrumental in the University securing a \$5 million endowment; \$1 million of this endowment has been earmarked for support of post-doctoral fellows at the Center for Coastal and Ocean Mapping. Our interaction with the private sector has been formalized into an industrial partner program that is continually growing.

- Airborne Hydrography AB
- Alidade Hydrographic
- AML Oceanographic
- Atlas Hydrographic-GmbH
- C&C Technologies Inc.
- CARIS, Inc.
- Chesapeake Technologies
- Clearwater Seafoods
- EarthNC
- EdgeTech
- Environmental Systems Research Institute, Inc. (ESRI)
- Fugro LADS Inc.
- Geocap
- HYPACK, Inc.
- IFREMER
- Instituto Hidrografico (IH)
- Kongsberg Underwater Technology, Inc. (KUTI)
- L-3 Communications Klein Associates
- Ocean High Technology Institute
- Ocean Imaging Consultants, Inc.
- Ocean Science
- ODIM Brooke Ocean Ltd. (ODIM)
- Odom Hydrographic Systems, Inc. (Odom)
- Optech
- Quality Positioning Services B.V. (QPS)
- Quester Tangent
- RESON, Inc.
- Science Applications International Corporation (SAIC)
- Seismic Micro Technology
- SevenCs
- Substructure
- Survice Engineering Company
- Teledyne Benthos, Inc.
- Triton Elics International, Inc.
- Tycom LTD
- YSI, Inc.

In addition, grants are in place with:

- National Science Foundation
- Nippon Foundation/GEBCO
- NOAA National Marine Fisheries Services
- Ocean Exploration Trust
- Office of Naval Research
- Schmidt Ocean Institute
- Systems & Technology Research, LLC
- University Corporation for Atmospheric Research
- U.S. Geological Survey

The Center also received support from other sources of approximately \$2.33 M for 2013 (see Appendix C).



## Appendix A: Graduate Degrees in Ocean Mapping

The University of New Hampshire offers Ocean Mapping options leading to Master of Science and Doctor of Philosophy degrees in Ocean Engineering and in Earth Sciences. These interdisciplinary degree programs are provided through the Center and the respective academic departments of the College of Engineering and Physical Sciences. The University has been awarded recognition as a Category "A" hydrographic education program by the International Federation of Surveyors (FIG)/International Hydrographic Organization (IHO)/International Cartographic Association (ICA). Requirements for the Ph.D. in Earth Sciences and Engineering are described in the respective sections of the UNH Graduate School catalog. MS degree requirements are described below.

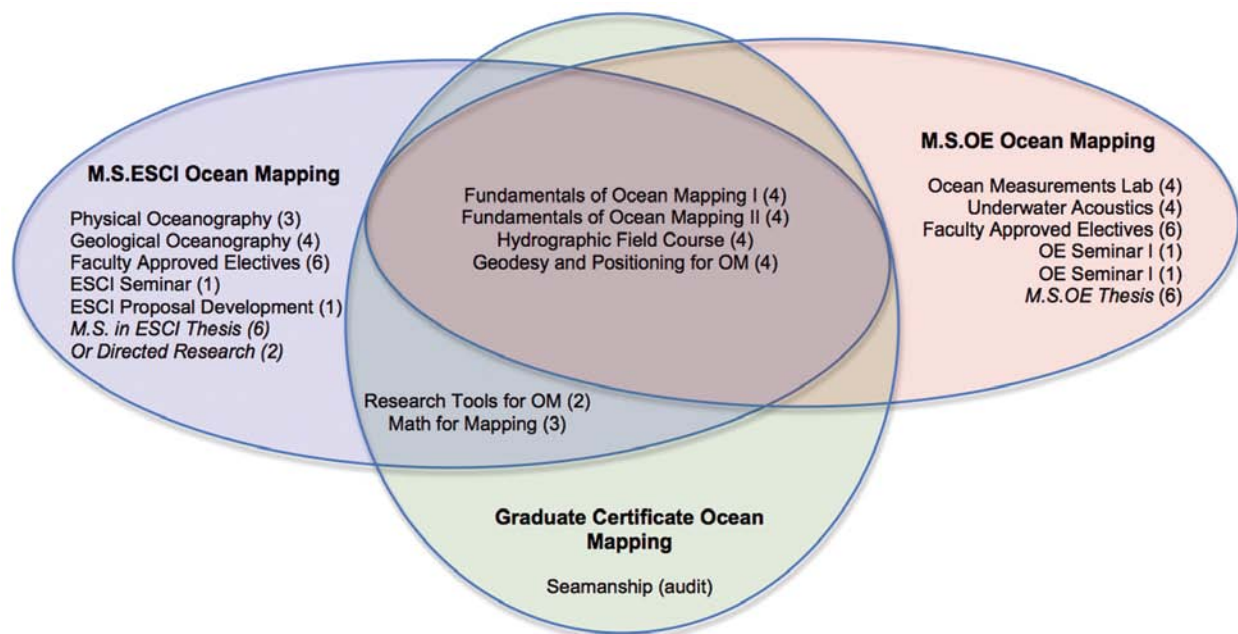

Figure 10-10. Curricula for master's degrees and certificates in Ocean Mapping at UNH JHC/CCOM.



Figure 10-11. 2013 incoming students.

## Master of Science in Ocean Engineering–Ocean Mapping Option

Core Requirements		Credit Hours
OE 810	Ocean Measurements Lab	4
OE/ESCI 874	Fundamentals of Ocean Mapping I	4
OE/ESCI 875	Fundamentals of Ocean Mapping II	4
OE/ESCI 871	Geodesy and Positioning for Ocean Mapping	3
OE/ESCI 895	Underwater Acoustics	3
OE/ESCI 972	Hydrographic Field Course	4
OE 990	Ocean Engineering Seminar I	1
OE 991	Ocean Engineering Seminar II	1
OE 899	Thesis	6
<b>At Least Six Additional Credits from the Electives Below</b>		
ESCI 858	Introduction to Physical Oceanography	3
OE 854	Ocean Waves and Tides	4
ESCI 859	Geological Oceanography	4
ESCI 959	Data Analysis Methods in Ocean and Earth Sciences	4
OE 954	Ocean Waves and Tides II	4
OE/EE 985	Special Topics	3
ESCI 907	Geo-Statistics	3
OE/ESCI 973	Seafloor Characterization	3
ESCI 895,896	Special Topics in Earth Science	1-4
ESCI 959	Data Analysis Methods in Ocean and Earth Science	4
ESCI 898	Directed Research	2
EOS 824	Introduction to Ocean Remote Sensing	3
NR 857	Photo Interpretation and Photogrammetry	4
NR 860	Geographic Information Systems in Natural Resources	4
OE/CS 867	Interactive Data Visualization	3
OE 995	Graduate Special Topics	2-4
OE 845	Environmental Acoustics I	4
OE 846	Environmental Acoustics II	4
OE 895	Time Series Analyses	4
OE 998	Independent Study	1-4
	Other related courses with approval	1-4

Where a course of equivalent content has been successfully completed as an undergraduate, an approved elective may be substituted.

## Master of Science in Earth Sciences—Ocean Mapping Option

Core Requirements		Credit Hours
ESCI 858	Introductory Physical Oceanography	3
ESCI 859	Geological Oceanography	4
MATH 896	Math for Mapping	3
ESCI/OE 874	Fundamentals of Ocean Mapping I	3
ESCI/OE 875	Fundamentals of Ocean Mapping II	3
ESCI/OE 871	Geodesy and Positioning for Ocean Mapping	3
ESCI 872	Research Tools for Ocean Mapping	2
ESCI/OE 972	Hydrographic Field Course	4
ESCI 997	Seminar in Earth Sciences	1
ESCI 998	Proposal Development	1
ESCI 899	Thesis	6
<b>Approved Electives</b>		
OE 810	Ocean Measurements Laboratory	4
OE 854	Ocean Waves and Tides	4
ESCI 959	Data Analysis Methods in Ocean and Earth Sciences	4
OE 954	Ocean Waves and Tides II	4
OE/EE 985	Special Topics	3
ESCI 907	Geostatistics	3
OE 845	Environmental Acoustics I	4
OE 846	Environmental Acoustics II	4
OE/ESCI 973	Seafloor Characterization	3
ESCI 895,896	Special Topics in Earth Science	1-4
ESCI 959	Data Analysis Methods in Ocean and Earth Science	4
ESCI 898	Directed Research	2
EOS 824	Introduction to Ocean Remote Sensing	3
NR 857	Photo Interpretation and Photogrammetry	4
NR 860	Geographic Information Systems in Natural Resources	4
OE/CS 867	Interactive Data Visualization	3
OE 995	Graduate Special Topics	2-4
OE 895	Time Series Analyses	4
OE 998	Independent Study	1-4

Where a course of equivalent content has been successfully completed as an undergraduate, an approved elective may be substituted.



## Master of Science in Earth Sciences (Non-Thesis Option)–Ocean Mapping Option

Core Requirements		Credit Hours
ESCI 858	Introductory Physical Oceanography	3
ESCI 859	Geological Oceanography	4
MATH 896	Math for Mapping	3
ESCI/OE 874	Fundamentals of Ocean Mapping I	3
ESCI/OE 875	Fundamentals of Ocean Mapping II	3
ESCI/OE 871	Geodesy and Positioning for Ocean Mapping	3
ESCI 872	Research Tools for Ocean Mapping	2
ESCI /OE 972	Hydrographic Field Course	4
ESCI 997	Seminar in Earth Sciences	1
ESCI 998	Proposal Development	1
ESCI 898	Directed Research	6
<b>At Least Four Additional Credits from the Electives Below</b>		
OE 810	Ocean Measurements Laboratory	4
OE 854	Ocean Waves and Tides	4
ESCI 959	Data Analysis Methods in Ocean and Earth Sciences	4
OE 954	Ocean Waves and Tides II	4
OE/EE 985	Special Topics	3
ESCI 907	Geostatistics	3
OE 845	Environmental Acoustics I	4
OE 846	Environmental Acoustics II	4
OE/ESCI 973	Seafloor Characterization	3
ESCI 895,896	Special Topics in Earth Science	1-4
ESCI 959	Data Analysis Methods in Ocean and Earth Science	4
ESCI 898	Directed Research	2
EOS 824	Introduction to Ocean Remote Sensing	3
NR 857	Photo Interpretation and Photogrammetry	4
NR 860	Geographic Information Systems in Natural Resources	4
OE/CS 867	Interactive Data Visualization	3
OE 995	Graduate Special Topics	2-4
OE 895	Time Series Analyses	4
OE 998	Independent Study	1-4

Where a course of equivalent content has been successfully completed as an undergraduate, an approved elective may be substituted.

## Graduate Certificate in Ocean Mapping

Core Requirements		Credit Hours
MATH 896	Math for Mapping	3
ESCI/OE 874	Fundamentals of Ocean Mapping I	4
ESCI/OE 875	Fundamentals of Ocean Mapping II	4
ESCI/OE 871	Geodesy and Positioning for Ocean Mapping	4
ESCI 872	Research Tools for Ocean Mapping	2
ESCI /OE 972	Hydrographic Field Course	4
Approved Electives		
ESCI 858	Introductory Physical Oceanography	3
ESCI 859	Geological Oceanography	4
OE 810	Ocean Measurements Laboratory	4
OE 854	Ocean Waves and Tides	4
ESCI 959	Data Analysis Methods in Ocean and Earth Sciences	4
OE 954	Ocean Waves and Tides II	4
OE/EE 985	Special Topics	3
ESCI 907	Geostatistics	3
OE 845	Environmental Acoustics I	4
OE 846	Environmental Acoustics II	4
OE/ESCI 973	Seafloor Characterization	3
ESCI 895,896	Special Topics in Earth Science	1-4
ESCI 959	Data Analysis Methods in Ocean and Earth Science	4
ESCI 898	Directed Research	2
EOS 824	Introduction to Ocean Remote Sensing	3
NR 857	Photo Interpretation and Photogrammetry	4
NR 860	Geographic Information Systems in Natural Resources	4
OE/CS 867	Interactive Data Visualization	3
OE 995	Graduate Special Topics	2-4
OE 895	Time Series Analyses	4
OE 998	Independent Study	1-4

Where a course of equivalent content has been successfully completed as an undergraduate, an approved elective may be substituted.

## Appendix B: Field Programs

Little Bay Surveys, Multiple Legs, January 14–March 27, UNH R/V *Galen J.* Single beam echosounder surveys in the Little Bay for bathymetric mapping and seafloor characterization studies. Comparisons will be made between full waveform acoustic backscatter properties and sediment grain size distributions. This work was initiated by seed funding from the NH Department of Environmental Services and will be continued as part of CCOM graduate student Joshua Humberston's thesis research funded by NOAA. (Jon Hunt, Tom Lippmann)

RR1301 Multibeam Advisory Committee (MAC) ship visit, January 21–28, R/V *Roger Revelle*. Full review of the R/V *Roger Revelle's* EM122 system including planning and conducting both a multibeam patch test and system performance test off the California coast, a review of the shipboard geometry, inspecting and correcting acquisition computer parameters, and installing MAC multibeam tools and documentation on the ships computers. Funded by the National Science Foundation. (Jonathan Beaudoin, Kevin Jerram, Ashton Flinders, Paul Johnson)

RR1301 Multibeam Advisory Committee (MAC) Quality Assurance Testing, January 21–28, R/V *Roger Revelle*. This cruise was an opportunity for the UNOLS Multibeam Advisory Committee (MAC) to conduct a Quality Assurance Test of the ship's Kongsberg EM122 multibeam echosounder during transit from San Diego, CA, to Anacortes, WA. Kevin Jerram assisted the MAC with documenting configurations and normal operating procedures for the echosounder and ancillary sensors to investigate abnormalities in depths of bottom detections in the outer beams of the swath. Documentation of the abnormalities was provided to the echosounder manufacturer for further investigation and resolution. (Jonathan Beaudoin, Paul Johnson, Kevin Jerram)

FK003 R/V *Falkor* EM302/EM710 checkup, February 28–March 5, R/V *Falkor*. Assess status of EM302 and EM710 multibeam echosounders. Funded by the Schmidt Ocean Institute (SOI). (Jonathan Beaudoin, Paul Johnson, Ashton Flinders, Jonathan Beaudoin)

EX1301 Ship Shakedown and Patch Test and Exploration, Northeast Canyons Mapping, March 18–April 5, NOAA Ship *Okeanos Explorer*. The cruise was focused on conducting annual mapping system shakedown, including a multibeam patch test. Meme Lobecker was the Expedition Coordinator, and Mapping co-lead with Mashkooor Malik. The cruise was conducted over a portion of the Northeast Atlantic Canyons as part of the NOAA OER ACUMEN project. (Meme Lobecker, Mashkooor Malik)

HRS130327AT ONR Bedforms, March 2013, March 27, R/V *Sharp*. The ONR Bedforms project is an effort to investigate the evolution of seafloor bedforms in and around structures on the seafloor and to apply fingerprint algorithms and other methods to characterize them. The effort involves both surface ship and AUV operations. Val Schmidt was the AUV engineer. (Chris Englert, Val E. Schmidt)

CastTime testing, April 8–12, NOAA Ship *Thomas Jefferson*. At-sea testing of Matt Wilson's graduate research software "CastTime" with MVP system on NOAA Ship *Thomas Jefferson*. (Jonathan Beaudoin, Matt Wilson, Jonathan Beaudoin)

2013 *Nautilus* Multibeam and SBP SAT, April 22–26, E/V *Nautilus*. Assess compliance of a Kongsberg EM302 multibeam system and Knudsen 3260 with respect to expected performance levels. Funded by Ocean Exploration Trust. (Jonathan Beaudoin, Paul Johnson)

Piscataqua Backscatter line NEWBEX, April 26–December 31, R/V *Coastal Surveyor*, R/V *Cocheco*. (Tom Weber, Ben Smith)

NEWBEX, May 1–January 2, R/V *Coastal Surveyor*, R/V *Cocheco*. Weekly NEWBEX backscatter cruises. (John Heaton)

EX1302 Ship Shakedown and Patch Test, ROV Shakedown and Field Trials, Northeast Canyons, May 13–June 6, NOAA Ship *Okeanos Explorer*. The first week of the cruise was dedicated to the annual Kongsberg maintenance visit, including a post-drydock multibeam patch test, an EK 60 calibration, and the collection of a multibeam reference surface. The majority of the cruise was focused on shaking down the new 6000 meter ROV (yet to be named) built by NOAA OER. Meme Lobecker was mapping team lead. ROV dive locations were chosen based on existing EX data, and new data collected during the cruise. Two new shallow water seep sites were discovered off the Mid-Atlantic states in 300–500 meters of water. (Meme Lobecker)



EM710 testing, May 24–31, NOAA Ship *Rainier*. The *Rainier* has been experiencing difficulties with their EM710 multi-beam echosounder. Glen Rice and Jonathan Beaudoin have been assisting them from afar for nearly a year. This ship visit allowed them to conduct sensor reconfiguration and further testing in a timely and efficient manner. (Jonathan Beaudoin, Glen Rice)

2013 season SURVICE/ARGUS data collection, June 1–December 15, R/V *Coastal Surveyor*, R/V *Cocheco*. Documented the installation of the ARGUS box on R/V *Coastal Surveyor* and provided it with reliable depth and position data for a feasibility study of ARGUS as an alternative hydrographic data source. (Semme J. Dijkstra, Ben Smith)

Summer Hydrographic Class for 2013, June 3–28, R/V *Coastal Surveyor*, R/V *Cocheco*. (Semme J. Dijkstra, Ben Smith)

Unit testing Klein HydroChart, June 5, R/V *Coastal Surveyor*, R/V *Cocheco*. Charter work for L3-Klein. Captain of Vessel (Ben Smith)

2013 Summer Hydro, June 10–28, R/V *Coastal Surveyor*. Mobilization and survey work with Kongsberg EM2010 MBES system in the context of the Summer Hydrographic field course (Ben Smith, Semme J. Dijkstra)

2013 Summer Hydro, June 11–28, R/V *Cocheco*. Mobilization and survey operation with Rolls Royce MVP30 system in the context of the summer hydrographic field course. Also, mobilization and survey operation with the Edgetech 4125 in the same context (Emily Terry, Semme J. Dijkstra)

NEWBEX, June 20, R/V *Galen J*. Obtain bottom video for seafloor characterization in support of NEWBEX. (Tom Weber, Glen Rice, Larry Ward)

Macroalgal Habitat Characterization, July 1–3, R/V *Coastal Surveyor*. This field study was designed to investigate the use of water-column backscatter and images derived from water-column backscatter for characterization and differentiation of habitat-forming benthic communities. (Scott Loranger, Tom Weber, Jon Hunt, Jenn Dijkstra)

Little Bay Sediment sampling, July 1–September 1, CBASS, Collected sediment samples in the Little Bay as part of Joshua Humberston's thesis work looking at sea floor characterization from single beam sonars. Analyzed samples with the Malvern Mastersizer Laser Particle Size Analyzer in Johnson's Geochemistry Lab. (Jon Hunt, Joshua Humberston, Tom Lippmann)

NEWBEX, July 3, R/V *Cocheco*. Obtained bottom sediment samples and video for seafloor characterization in support of NEWBEX. (John Heaton, Eric Bajor, Larry Ward)

NA030 Hydrocarbon Detection in Marine Environments—Leg 1, July 5–18, E/V *Nautilus*. This privately funded research cruise (Leg 1 of 2) involved water column mapping of natural methane seeps in the Gulf of Mexico using the Kongsberg EM302 multibeam echosounder installed on E/V *Nautilus*. Kevin Jerram processed all bathymetry during the cruise and supervised two four-hour shifts each day as a mapping Watch Leader. (Tom Weber, Jonathan Beaudoin, Paul Johnson, Chris Englert, Kevin Jerram)

NA030 Natural Hydrocarbon Seep Detection Mapping, July 8–17, E/V *Nautilus*. Part 1 of a 2 part expedition in the Gulf of Mexico to map natural hydrocarbon seeps using a Kongsberg EM302 and Knudsen subbottom. (Paul Johnson)

NA Hampton Salt Marsh Mapping, July 12–December 16. Obtained GNSS positions on monument located within the salt marshes surrounding Hampton Beach, NH. (Semme J. Dijkstra)

Tagging Steller sea lions, July 18. Tags containing gyros as well as accelerometers were attached to Steller sea lions in the UBC open water facility. Burrard Inlet, Vancouver, British Columbia. Colin Ware supplied the tags and is the lead author on a paper that is in preparation. (Colin Ware)

NA032 Hydrocarbon Detection in Marine Environments—Leg 2, July 27–August 12, E/V *Nautilus*. This privately funded research cruise (Leg 2 of 2) revisited natural methane seep sites mapped during NA030 for investigation with the Hercules and Argus remotely operated vehicles (ROVs) aboard E/V *Nautilus*. Kevin Jerram stood two or three four-hour watches each day as Navigator for the ROVs and processed all water column data from the ship's Kongsberg EM122 multibeam echosounder to relocate seeps detected during NA030 and inform ROV dive plans. (Tom Weber, Kevin Jerram)

HRS130729 ONR Bedforms, July 2013, July 29–August 2, R/V *Sharp*, ONR Bedforms is an ONR funded project (Trembanis and Mayer are the PIs) for repeat surveys to characterize the evolution of seafloor bedforms with environmental changes. (Chris Englert, Val E. Schmidt)

Ocean Explorer of Sweden, July 30–August 17. Exploration mapping in Upernavik, Greenland. (Larry Mayer)

Rapid Assessment Survey, August 4–8, Rapid Assessment Surveys (RAS) are spatial and temporal assessments of introduced and native species and began in 2001. A group of international taxonomic experts survey ~ 17 sites from Maine to Rhode Island. Jenn Dijkstra served as a taxonomic expert for the survey and collected native and non-native species that will be used to investigate their population structure collaborating with Dr. Marianne Litvaitis in the Department of Natural Resources at UNH. (Jenn Dijkstra)

EX1305 ECOMON, August 23–September 5, NOAA Ship *Okeanos Explorer*. Environment Monitoring cruise run by NMFS (Mashkoor A. Malik)

Inter Sonar Field Calibration Testing Using Three NOAA Launches, August 25–September 7, NOAA Ship *Fairweather*. Tested concept of inter-sonar calibration field procedure using three NOAA launches operated by NOAA Ship *Fairweather* and staged out of Newport, OR. (Briana Welton)

MB1 Field Trials, September 4, R/V *Coastal Surveyor*, R/V *Cocheco*. Evaluation survey of the new Teledyne MB-1 sonar. (Jonathan Beaudoin, Val E. Schmidt)

NA Odom MB-1 Eelgrass Mapping, September 9, R/V *Coastal Surveyor*. We collected Odom MB-1 multibeam data as we had the opportunity to do so and need to get familiar with the MB-1 as it is likely the system that Ashley Norton will be using as the primary data acquisition system for her research work. The data was collected near the Southern tip of Gerrish Island and includes areas with no eelgrass coverage, patchy coverage and full coverage. (Ashley Norton, Semme J. Dijkstra)

UNH Police Portsmouth Harbor Portsmouth Mapping, September 27, R/V *Coastal Surveyor*. Klein HydroChart survey in Portsmouth Harbor assisting the UNH Police in their search for the remains of a student who was believed to have committed suicide by jumping into the Piscataqua River. (Brian Calder, Val E. Schmidt, Christina Fandel)

NEWBEX, October 21, R/V *Gulf Challenger*. Collection of video data in support of differentiating among benthic habitats using water-column backscatter (Larry Ward, Kevin Jerram, Tom Weber, Jenn Dijkstra)

NEWBEX, October 21, R/V *Gulf Challenger*. Obtain bottom sediment samples and video for seafloor characterization in support of NEWBEX. (Tom Weber, Kevin Jerram, Jenn Dijkstra, Larry Ward)

Barnegut Bay Eelgrass Habitat Mapping, October 24–28. Evaluate the use of topographic-bathymetric lidar for shallow water benthic habitat characterization in the flood tidal delta complex of Barnegut Inlet. Photographic data collected for this project will also be used in a study investigating the latitudinal distribution of non-native species in eelgrass beds. This project includes the Department of Fisheries and Oceans (CA), University of Prince Edward Island (CA), EPA, WHOI, and the National Park Service. (Lindsay McKenna, Chris Parrish, Jenn Dijkstra)

HRS1323 ONR Bedforms, November 2013, November 12–15, R/V *Sharp*. ONR Bedforms is an ONR-funded project (Trembanis and Mayer are the PIs) to conduct repeat seafloor surveys to characterize the evolution of seafloor bedforms. (Chris Englert, Val E. Schmidt)

Newbex NEWBEX CBASS Surveys, November 15–December 31, CBASS. Conducting CBASS surveys for mean currents as part of NEWBEX. Mean currents will quantify the vertical variation in flow field for estimating shear stresses needed for sediment transport calculations. (Tom Weber, Jon Hunt, Eric Bajor, John Heaton, Tom Lippmann)

## Appendix C: Other Funding

Name of Project	PI	Grantor	FY Award	Total Award	Length
Large Scale Observation of Fine Scale Seabed Morphology and Flow Structure of Tidally Modulated Inlets: Analysis of the New River Field Data	Lippmann, T.	Office of Naval Research	63,378	126,756	1 year
Machine Services for OKEANOS	Mayer, L.	University Corporation for Atmospheric Research	11,250	11,250	1 year
Support for R/V <i>Falkor</i> Mapping Support	Mayer, L.	Ocean Exploration Trust	19,260	19,260	1 year
Support for R/V <i>Nautilus</i> Mapping Support	Mayer, L.	Schmidt Ocean Institute	83,600	83,600	1 year
GEBCO 10th Year	Mayer, L.	General Bathymetric Chart of the Oceans	570,000	2,745,455	5 years
Indian Ocean Project	Mayer, L.	General Bathymetric Chart of the Oceans	48,073	245,269	2 years
Tyco Endowment Interest from perpetuity	Mayer, L.	TYCO	46,737	-	in perpetuity
E/V <i>Nautilus</i> Mapping Support	Mayer, L.	Ocean Exploration Trust	48,024	48,024	1 month
Bedform Parameterization and Object Detection from Sonar Data Application of Finger Print Algorithms.	Mayer, L. Beaudoin, J.	UDEL/Office of Naval Research	17,182	58,148	18 months
Processing of Aerial Imaging	Rzhanov, Y.	U. Mass Amherst/NOAA National Marine Fisheries Services	4,124	4,124	18 months
Seafloor Video Mosaic Research	Rzhanov, Y.	U.S. Geological Survey	10,000	40,000	3 years
Modeling Statistics of Fish	Weber, T. Ware, C. Calder, B.	Office of Naval Research	81,963	220,069	3 years
Collaborative Research: Optimizing Multibeam Data Acquisition, Operations and Quality for the US Academic Research Fleet	Beaudoin, J. Johnson, P.	National Science Foundation	56,823	420,527	3 years
IOCM Research in Support of Super Storm Sandy Disaster Relief	Calder, B. Mayer, L.	National Oceanic Atmospheric Administration	999,984	999,984	2 years
Visualization Human Systems	Ware, C.	Systems & Technology Research, LLC	103,484	205,000	2 years
Enhancements to a Mission Planning Application through Visualization of Currents, Sea State and Weather Variables, and Improvements in Bathymetric Modeling	Ware, C. Calder, B.	Office of Naval Research	167,641	167,641	1 year
<b>TOTAL</b>			<b>2,331,523</b>	<b>5,392,107</b>	



## Appendix D: Publications

### Journal Articles

- Brothers, Laura, VanDover, C. L., German, Christopher R., Kaiser, C. L., Yoerger, Dana, Ruppel, Carolyn, Lobecker, Elizabeth (Meme), Skarke, Adam, and Wagner, J.K.S., (2013), Evidence for extensive methane venting on the southeastern U.S. Atlantic margin, *Geology*, 41, 807–810.
- Dijkstra, Jennifer A., Lambert, W. J., and Harris, L. G., (2013), Introduced species provide a novel temporal resource that facilitates native predator population growth, *Biological Invasions*, 15, 911–919.
- Dijkstra, Jennifer A., Buckman, K. L., Ward, D., Evans, D. W., Dionne, M., and Chen, C. Y., (2013), Experimental and natural warming elevates mercury concentrations in estuarine fish, *PLoS ONE*, 8, e58401.
- Gardner, James V., Armstrong, Andrew A., Calder, Brian R., and Beaudoin, Jonathan, (2013), So, how deep is the Mariana Trench?, *Geology*, DOI:10.1080/01490419.2013.837849.
- Gardner, James V., Calder, Brian R., and Malik, Mashkoor A., (2013), Geomorphometry and processes that built Necker Ridge, central North Pacific Ocean, *Marine Geology*, 346, 310–325.
- Lin, Weiren, Conin, Marianne, Moore, Casey J., Chester, Frederick M., Nakamura, Yasuyuki, Mori, James J., Anderson, Louise, Brodsky, Emily E., Eguchi, Nobuhisa, Cook, Becky, et al., (2013), Stress State in the Largest Displacement Area of the 2011 Tohoku-Oki Earthquake, *Science*, 339, Number 6120, 687–690.
- Masetti, Giuseppe, and Calder, Brian R., (2013), Design of a standardized geo-database for risk monitoring of potentially polluting marine sites, *Environment Systems and Decisions*, 12.
- Mitchell, Garrett A., Mayer, Larry A., Bell, K L, Raineault, Nicole A., Roman, Chris, Ballard, Robert, Cornwell, K., Hine, A., Shinn, E., Dimitriadis, I., et al., (2013), Exploration of Eratosthenes Seamount—A continental fragment being forced down an oceanic trench, *Oceanography*, 26, 36–41.
- Parrish, Christopher E., Rogers, Jeff, and Calder, Brian R., (2013), Assessment of Waveform Shape Features for Lidar Uncertainty Modeling in a Coastal Salt Marsh Environment, *Geoscience and Remote Sensing Letters*, Vol. 11, No. 2, 569–573.
- Pe'eri, Shachak, McLeod, M.A., Lovoie, P., Ackerman, S, Gardner, James V., and Parrish, Christopher E., (2013), Field calibration and validation of remote sensing surveys, *International Journal of Remote Sensing*, 34, 6423–6436.
- Pe'eri, Shachak, and Shwaery, Glenn, (2013), Radiometric and Photometric Determinations of Simulated Shallow-Water Environment, *International Journal of Remote Sensing*, 34(18), 6437–6450.
- Stockwell, J. D., Weber, Thomas C., Baukus, A. J., and Jech, J M., (2013), On the use of omnidirectional sonars and downwards-looking echosounders to assess pelagic fish distributions during and after midwater trawling, *ICES Journal of Marine Science: Journal du Conseil*, 70(1), 196–203.
- Trembanis, A. C., Duval, C., Beaudoin, Jonathan, Schmidt, Val E., Miller, D., and Mayer, Larry A., (2013), A detailed seabed signature from Hurricane Sandy revealed in bedforms and scour, *Geochemistry, Geophysics, Geosystems*, 14, 4334–4340.
- Ujiie, Kohtaro, Tanaka, Hanae, Saito, Tsubasa, Tsutsumi, Akito, Mori, James J., Kameda, Jun, Brodsky, Emily E., Chester, Frederick M., Eguchi, Nobuhisa, Toczko, Sean, et al., (2013), Low Coseismic Shear Stress on the Tohoku-Oki Megathrust Determined from Laboratory Experiments, *Science*, 342.
- Weber, Thomas C., Rooper, Christopher, Butler, John, Jones, Darin, and Wilson, Chris, (2013), Seabed classification for trawlability determined with a multibeam echosounder on Snakehead Bank in the Gulf of Alaska, *Fishery Bulletin*, 111, Number 1, 68–77.
- Weber, Thomas C., Lutcavage, Molly E., and Schroth-Miller, Madeline L., (2013), Near resonance acoustic scattering from organized schools of juvenile Atlantic bluefin tuna (*Thunnus thynnus*), *The Journal of the Acoustical Society of America*, 133, 3802–3812.

## Book Sections

Dahlgren, Thomas, Schläppy, Marie-Lise, Shashkov, A., Andersson, M., Rzhannov, Yuri, Fer, I., and Heggøy, E., (2013), Assessing impact from wind farms at subtidal, exposed marine areas, *Marine Renewable Energy and Environmental Interactions*, Springer.

Pe'eri, Shachak, Madore, Brian, Alexander, Lee, Parrish, Christopher E., Armstrong, Andrew A., and Azuike, Chukwu-ma, (2013), LANDSAT 7 Satellite-Derived Bathymetry, *The IHO-IOC GEBCO Cook Book*, Edition 2.25.13, International Hydrographic Office (IHO)/ International Ocean Commission (IOC), Monaco, Monaco Cedex, Monaco.

## Conference Abstracts

Beaudoin, Jonathan, Weber, Thomas C., Jerram, Kevin, Rice, Glen A., Malik, Mashkoor A., and Mayer, Larry A., (2013), Multibeam Echosounder System Optimization for Water Column Mapping of Undersea Gas Seeps, FEMME-2013, Boston, MA, April 16–18.

Beaudoin, Jonathan, (2013), Multibeam Advisory Committee: Improving Data Quality Across the U.S. Academic Fleet, FEMME-2013, Boston, MA, April 16–18.

Brumley, K., Mukasa, S. B., O'Brien, T. M., Mayer, Larry A., and Chayes, Dale N., (2013), Dredged Bedrock Samples from the Amerasia Basin, Arctic Ocean, 2013 Fall Meeting, American Geophysical Union (AGU), San Francisco, CA, December 9–13.

Dijkstra, Jennifer A., and Brown, Clancy, (2013), Effect of morphological transformation on habitat structure and associated species, Benthic Ecology Meeting, Savannah, GA, March 20–24.

Dijkstra, Jennifer A., (2013), Facilitation of native and non-native species by intermediate foundation species, Coastal and Estuarine Research Federation, November 3–7.

Duval, C., Trembanis, A.C., Beaudoin, Jonathan, Schmidt, Val E., and Mayer, Larry A., (2013), Hurricane Sandy's Fingerprint: Ripple Bedforms at an Inner Continental Shelf Sorted Bedform Field Site, 2013 Fall Meeting, American Geophysical Union (AGU), San Francisco, CA, December 9–13.

Jakobsson, Martin, Mayer, Larry A., and Marcussen, C., (2013), Scientific Discoveries in the Central Arctic Ocean Based on Seafloor Mapping Carried Out to Support Article 76 Extended Continental Shelf Claims, 2013 Fall Meeting, American Geophysical Union (AGU), San Francisco, CA, December 9–13.

Kirkpatrick, James D., Ujiie, Kohtaro, Mishima, Toshiaki, Chester, Frederick M., Rowe, Christie D., Regalla, Christine, Remitti, Francesca, Moore, J.C., Toy, Virginia, Kameda, Jun, et al., (2013), Internal structure of the shallow Japan Trench décollement: insights into the long-term evolution of the margin and coseismic slip processes, 2013 Fall Meeting, American Geophysical Union (AGU), December 9–13.

Malik, Mashkoor A., Lobecker, Elizabeth (Meme), and Skarke, Adam, (2013), Lessons learned during exploration mapping of US East Coast 2011 – 2012 onboard NOAA Ship *Okeanos Explorer* using water column backscatter data, Kongsberg FEMME 2013, April 15–19.

O'Brien, T. M., Brumley, K., Miller, E. L., and Mayer, Larry A., (2013), The Caledonian suture in the high Arctic? New Data from the Chukchi Borderland, Amerasia Basin, 2013 Fall Meeting, American Geophysical Union (AGU), San Francisco, CA, December 9–13.

Parrish, Christopher E., (2013), Lidar Waveform: A Practical Perspective, American Society for Photogrammetry and Remote Sensing (ASPRS) Annual Conference, March 24–28.

Schmidt, Val E., (2013), Acoustic Surface Backscatter vs. Incidence Angle from Glacial Ice, FEMME-2013, Boston, MA, June 16–19.

Sowers, Derek, Mayer, Larry A., and Gardner, James V., (2013), Utilizing New Multibeam Sonar Datasets to Map Potential Locations of Sensitive Benthic Habitats in the U.S. Atlantic Extended Continental Shelf, 2013 Fall Meeting, American Geophysical Union (AGU), San Francisco, CA, December 9–13.

Trembanis, A.C., Beaudoin, Jonathan, Duval, C., Schmidt, Val E., and Mayer, Larry A., (2013), Morphodynamic Impacts of Hurricane Sandy on the Inner-shelf, 2013 Fall Meeting, American Geophysical Union (AGU), San Francisco, CA, December 9–13.

Welton, Briana, Beaudoin, Jonathan, Weber, Thomas C., Lanzoni, Carlo, and Rice, Glen A., (2013), Development of a Method for a Relative Backscatter Field Calibration using Reson 7125 Multibeam Sonar Systems, US Hydrographic Conference 2013, New Orleans, LA, March 25–28.

Whitcomb, Louis L., Bowen, Andrew, Yoerger, Dana, German, Christopher R., Kinsey, J, Mayer, Larry A., Jakuba, Michael, Gomez-Ibanez, D, Taylor, Christopher, Machado, Casey, et al., (2013), Design and Fabrication of Nereid-UI: A Remotely Operated Underwater Vehicle for Oceanographic Access Under Ice, 2013 Fall Meeting, American Geophysical Union (AGU), San Francisco, CA, December 9–13.

Wolfson-Schwehr, Monica L., Boettcher, Margaret S., McGuire, Jeffrey J., and Collins, John A., (2013), The Relationship Between Seismicity and Fault Structure on the Discovery Transform Fault, East Pacific Rise, 2013 Fall Meeting, American Geophysical Union (AGU), San Francisco, CA, December 9–13.

### Conference Posters

Beaudoin, Jonathan, (2013), Oceanographic Weather Maps: Using Oceanographic Models to Improve Seabed Mapping Planning and Acquisition, US Hydrographic Conference 2013, New Orleans, LA, March 25–28.

Calder, Brian R., (2013), Distribution-free, Variable Resolution Depth Estimation with Composite Uncertainty, U.S. Hydrographic Conference, New Orleans, LA, March 25–27.

Calder, Brian R., (2013), Parallel and Distributed Performance of a Depth Estimation Algorithm, U.S. Hydrographic Conference, New Orleans, LA, March 25–27.

Englert, Chris, (2013), Designing Improved Sediment Transport Visualizations, MTS/IEEE Oceans 2013, San Diego, CA, September 23–26.

Eren, Firat, Pe'eri, Shachak, and Thein, May-Win, (2013), Characterization of optical communication in a leader-follower unmanned underwater vehicle formation, SPIE Defense, Security and Sensing (Ocean remote sensing and monitoring V), Baltimore, MD, April 29–May 3.

Fadahunsi, Olumide, Pe'eri, Shachak, Parrish, Christopher E., Armstrong, Andrew A., and Alexander, Lee, (2013), Spectral characterization of the Nigerian shoreline using Landsat imagery, US Hydrographic Conference 2013, New Orleans, LA, March 25–28.

Grassi, M., Carmisciano, C., Cocchi, L., Djaliti, L., Filippone, M., Guideri, M., Ivaldi, R., Masetti, Giuseppe, Muccini, F., Pratellesi, M., et al., (2013), Caratterizzazione dell'ambiente marino dei Campi Flegrei. Risultati preliminari della campagna oceanografica RICAMAR 2013, 17a Conferenza Nazionale ASITA, Riva del Garda, Italy, November 5–7.

Greenaway, Samuel F., (2013), A Single Vessel Approach to Inter-Vessel Normalization of Seafloor Backscatter Data, US Hydrographic Conference 2013, March 25–28.

Heaton, John L., Weber, Thomas C., Rice, Glen A., and Lurton, Xavier, (2013), Testing of an extended target for use in high frequency sonar calibration, Proceedings of Meetings on Acoustics, June 2–7.

Imahori, Gretchen, Pe'eri, Shachak, Parrish, Christopher E., Wozumi, Toshi, White, Stephen A., Jeong, Inseong, and Macon, Christopher L., (2013), Developing an acceptance test for non-hydrographic airborne bathymetric lidar data application to NOAA charts in shallow waters, US Hydrographic Conference, New Orleans, LA, March 25–28.

Jakobsson, Martin, (2013), Arctic Ocean Bathymetry: A required geospatial framework, The Arctic Observing Summit, April 30–May 2.

Jerram, Kevin, Weber, Thomas C., and Beaudoin, Jonathan, (2013), Observing natural methane seep variability in the northern Gulf of Mexico with an 18-kilohertz split-beam scientific echosounder, Proceedings of Meetings on Acoustics, 2–7 June.



- Lamey, B., Riley, Jack, Froelich, Grant, Miller, James, and Calder, Brian R., (2013), Variable Resolution Bathymetric-Gridding Technology for Nautical Charting: Case Study CHRT Data, US Hydrographic Conference, New Orleans, LA, March 25–27.
- Lippmann, Thomas C., (2013), Subtidal Flow Structure in Tidally Modulated Inlets, Coastal Dynamics 2013, Plymouth, England, United Kingdom, June 24.
- Malik, Mashkoo A., Mayer, Larry A., Weber, Thomas C., Calder, Brian R., and Huff, Lloyd C., (2013), Challenges of defining uncertainty in multibeam sonar derived seafloor backscatter, International Underwater Acoustic Conference and Exhibition, Corfu, Greece, June 24–28.
- Miao, Dandan, and Calder, Brian R., (2013), Gradual Generalization of Nautical Chart Contours with a Cube B-Spline Snake Model, IEEE Oceans, San Diego, CA, September 23–26.
- Pe'eri, Shachak, Parrish, Christopher E., Alexander, Lee, Azuike, Chukwuma, Armstrong, Andrew A., and Sault, Maryellen, (2013), Future directions in hydrography using satellite-derived bathymetry, US Hydrographic Conference, New Orleans, LA, March 25–28.
- Schmidt, Val E., Weber, Thomas C., and Lurton, Xavier, (2013), Optimizing Resolution and Uncertainty in Bathymetric Sonar Systems, Conference Underwater Acoustic Measurements: Technologies and Results, Corfu, Greece, June 23–29.
- Weber, Thomas C., Jerram, Kevin, Rzhhanov, Yuri, Mayer, Larry A., and Loyalvo, Dave, (2013), Acoustic and optical observations of methane gas seeps in the Gulf of Mexico, Proceedings of Meetings on Acoustics, June 2–7.
- Wilson, Matt, Beaudoin, Jonathan, and Steve Smyth, (2013), Water-Column Variability Assessment for Underway Profilers to Improve Efficiency and Accuracy of Multibeam Surveys, U.S. Hydrographic Conference, New Orleans, LA, March 25–28.

## Reports

- Andrews, B.D., (2013), Bathymetric terrain model of the Atlantic margin for marine geological investigations, U.S. Geological Survey Open-File Report, pp. 11.
- Carmisciano, C., Grassi, M., Cocchi, L., Masetti, Giuseppe, Filippone, M., Ricci, E., Pratellesi, M., Ivaldi, R., Iannaccone, G., Berrino, G., et al., (2013), RICAMAR2013: Rilievi per la caratterizzazione dell'ambiente marino nel Golfo di Pozzuoli. Rapporto sull'attività. 13–31 maggio 2013, Rapporti Tecnici INGV (ISSN 2039-7941), Istituto Nazionale di Geofisica e Vulcanologia, pp. 56, vol. 262(2013).
- Imahori, Gretchen, Ferguson, Jeff, Wozumi, Toshi, Scharff, Dave, Pe'eri, Shachak, Parrish, Christopher E., White, Stephen A., Jeong, Inseong, Sellars, Jon, and Aslaksen, M., (2013), A procedure for developing an acceptance test for airborne bathymetric lidar data application to NOAA charts in shallow waters, National Oceanic and Atmospheric Administration (NOAA), National Ocean Survey (NOS), NOAA Technical Memorandum NOS CS 32, Silver Spring, MD, pp. 53.

## Theses

- Fandel, Christina, *Observations of Pockmark Flow Structure in Belfast Bay, Maine*, Master of Science in Earth Sciences with an Ocean Mapping Option.
- McKenna, Lindsay, *Patterns of Bedform Migration and Mean Tidal Currents in Hampton-Seabrook Inlet, NH*, Master of Science in Earth Sciences with an Ocean Mapping Option.

## Appendix E: Technical Presentations and Seminars

### Seminars

Yuri Rzhakov, Shachak Peeri, January 7–10, ROV Class (ME 895), UNH J-Term Class, Durham, NH.

Rochelle Wigley, January 20–22, Indian Ocean Bathymetric Compilation Project, GEBCO Scholars, Chittagong, Bangladesh.

Shachak Peeri, February 3, Israel Oceanographic and Limnological Research (IOLR) Seminar, IOLR, Haifa, Israel.

Rochelle Wigley, March 4–6, 5th ROPME Sea Area Hydrographic Commission Conference, RSAHC, Riyadh, Kingdom of Saudi Arabia.

Chris Parrish, Shachak Peeri, March 4–8, Surface Analysis (OE 875), JHC/CCOM, Durham, NH.

Ben Smith, March 22, UNIX, Linux: Why They Are Important to Research, JHC/CCOM, Durham, NH.

Chris Parrish, Shachak Peeri, April 1–5, Optical Remote Sensing (OE875), JHC/CCOM, Durham, NH.

Shachak Peeri, April 5, Framework for Optical Communication Between Unmanned Underwater Vehicles, JHC/CCOM, Durham, NH.

Christina Fandel, April 17, Observations of Pockmark Flow Structure in Belfast Bay, Maine, JHC/CCOM, Durham, NH.

Jenn Dijkstra, April 18, Predicting the distribution of non-native species in Maine coastal waters, Maine Invasive Species Network, Portland, ME.

John Heaton, May 3, Testing of an Extended Target for High Frequency Sonar Calibration, mechanical engineering graduate student class, Durham, NH.

Thomas Butkiewicz, May 21, Multi-touch 3D Interfaces for Exploratory Analysis of Dynamic Ocean Models, NOAA NCEP, College Park, MD.

Jenn Dijkstra, October 2, Synergisms among foundation species, climate change and invasions, University of Massachusetts, Boston, MA.

Jenn Dijkstra, October 7, Foundation species and invasions, Zoology 400, Durham, NH.

Monica L. Wolfson, October 23, The Relationship Between Seismicity and Fault Structure on the Discovery Transform Fault, East Pacific Rise, USGS Menlo Park, Menlo Park, CA.

Thomas Butkiewicz, November 4, Exploratory Visual Analysis of Dynamic Ocean Models, UNH Computer Science, Durham, NH.

Jon Hunt, Larry Ward, Tom Lippmann, November 8, Observations of Tidal and Subtidal Currents around Inlets, JHC/CCOM, Durham, NH.

### Technical Presentations

Brian Calder, Invited, January 30, Implications in Survey of a CHRT Implementation, NOAA Office of Coast Survey (OCS), NOAA Field Procedures Workshop, Norfolk, VA.

Tom Lippmann, Invited, January 31, Observations of Currents in Two Tidally Modulated Inlets, Dept. of Earth Sciences, UNH, Chapman Colloquium, Durham, NH.

Thomas Butkiewicz, Contributed, February 5, Designing geospatial data visualizations for a general audience, Gulf of Maine Research Institute and Workshop Attendees, Workshop on Data Visualization to Support Ecosystem Based Management, Portland, ME.

- Yuri Rzhanov, Contributed, February 5–7, Assessing impact from wind farms at subtidal, exposed marine areas, University of Stockholm.
- Jonathan Beaudoin, Paul Johnson, Contributed, February 11, Multibeam Discussion and MAC Tools, RVTEC, Research Vessel Technical Enhancement Committee (RVTEC) Meeting, Palisades, NY.
- Larry Mayer, Invited, February 12, Ocean Mapping, Chief of Naval Operations Strategic Study Group, Naval War College, Newport, RI.
- Monica L. Wolfson, Invited, February 22, The Effect of Segmentation on Oceanic Transform Fault Seismicity and Thermal Structure, Stanford University, Stanford Structural Geology Seminar, Stanford, CA.
- Colin Ware, Invited, March 3, Visual Thinking Algorithms, University of British Columbia, Department of Computer Science Distinguished Lecture Series, Vancouver, BC, Canada.
- Colin Ware, Invited, March 15, Humpback Whale Foraging Kinematics: Midwater Lunges, Bubble Netting, Bottom Feeding, Marine Mammal Research Unit, UBC, Seminar series, Vancouver, BC, Canada.
- Colin Ware, Invited, March 20, Perceptual Theory and 2D Flow Visualization: Ocean Currents, Waves and Wind Patterns, Simon Fraser University, School of Interactive Arts and Technology, Seminar Series, Vancouver, BC, Canada.
- Chris Parrish, Andrew Armstrong, Lee Alexander, Chukwuma Azuike, Shachak Peeri, Contributed, March 25–28, Future directions in hydrography using satellite-derived bathymetry, THSOA, U.S. Hydrographic Conference 2013, New Orleans, LA.
- Chris Parrish, Shachak Peeri, Contributed, March 25–28, Developing an acceptance test for non-hydrographic airborne bathymetric lidar data application to NOAA charts in shallow waters, THSOA, U.S. Hydrographic Conference, New Orleans, LA.
- Brian Calder, Contributed, March 27, Distribution-free, Variable Resolution Depth Estimation with Composite Uncertainty, U.S. Hydrographic Conference, New Orleans, LA.
- Brian Calder, Contributed, March 27, Parallel and Distributed Performance of a Depth Estimation Algorithm, U.S. Hydrographic Conference, New Orleans, LA.
- Larry Mayer, Invited, March 28, The Arctic and the Gulf Oil Spill: What if Deepwater Horizon happened in the Arctic?, Seacoast Science Center, Heritage Dinner Series, Rye, NH.
- Monica L. Wolfson, Invited, April 3, The Effect of Segmentation on Oceanic Transform Fault Seismicity and Thermal Structure, Boston University, Solid Earth Seminar, Boston, Massachusetts.
- Jim Irish, Jon Hunt, Tom Lippmann, Contributed, April 9, Observations of the Vertical Structure of Tidal Currents in Two Inlets, Conference participants of the ICS, International Coastal Symposium, Plymouth, England, United Kingdom.
- Larry Mayer, Keynote, April 17, An “Almost Old” Man’s Look at from Whence We’ve Come and Where we Might be Going, FEMME 2013, Boston, MA.
- Val E. Schmidt, Contributed, April 18, Acoustic Surface Backscatter vs. Incidence Angle from Glacial Ice, Kongsberg User Group, FEMME 2013, Boston, MA.
- Jim Irish, Tom Lippmann, Invited, April 24, Vertical Structure of Subtidal Currents, ONR, RIVET Workshop, Washington, DC.
- Larry Mayer, Invited, April 25, New Directions in Visualizing the Ocean: From D-Day to Deepwater Horizon to Law of the Sea, Worcester State University, Worcester, MA.
- Thomas Butkiewicz, Invited, May 21, Multi-touch 3D Exploratory Analysis of Ocean Flow Models, NOAA NCEP, College Park, MD.
- Larry Mayer, Invited, May 23, U.S. Seabed and Habitat Mapping Initiatives, The Atlantic—A Shared Resource, Galway, Ireland.



Tom Weber, Jonathan Beaudoin, Kevin Jerram, Contributed, June 6, Observing natural methane seep variability in the northern Gulf of Mexico with an 18-kHz split-beam scientific echosounder, Acoustical Society of America / International Congress on Acoustics / Canadian Acoustical Association, International Congress on Acoustics 2013, Montreal, Quebec, Canada.

Tom Weber, Glen Rice, John Heaton, Contributed, June 6, Testing of an Extended Target for High Frequency Sonar Calibration, Acoustical Society of America, International Congress of Acoustics, Montreal, Quebec, Canada.

Tom Weber, Jonathan Beaudoin, Kevin Jerram, Contributed, June 6, Observing natural methane seep variability in the northern Gulf of Mexico with an 18-kHz split-beam scientific echosounder, Acoustical Society of America/International Congress on Acoustics / Canadian Acoustical Association, Joint meeting of ASA/ICA/CAA, Montreal, Quebec, Canada.

Briana Sullivan, Contributed, June 19, ChUM: Chart Update Mashup, NOAA, Virtual Coastal GeoTools 2013, Durham, NH.

Larry Mayer, Glen Rice, Meme Lobecker, Andrew Armstrong, Derek Sowers, Invited, June 24, Extracting Habitat Information from Extended Continental Shelf Project Data, NOAA Office of Exploration and Research, Extracting Habitat Information from Extended Continental Shelf Project Data, Silver Spring, MD.

Jim Irish, Tom Lippmann, Contributed, June 27, Subtidal Flow Structure in Tidally Modulated Inlets, conference participants of the Coastal Dynamics 2013, Coastal Dynamics 2013, Arcachon, France.

Larry Mayer, Invited, July 17, Mapping the Extended Continental Shelf in an Changing Arctic, 5th Symposium on the Impacts of an Ice-Diminishing Arctic on Naval and Maritime Operations, Navy Memorial, Washington, DC.

Sarah Wolfskehl, Keynote, August 1, Developing a Hydrographic Workflow for the ME70, Integrated Ocean and Coastal Mapping Group, IOCM Coordination Team Meeting, Durham, NH.

Larry Mayer, Invited, August 29, Ocean Mapping: Exposing the Secrets of the Deep, Aquarium of the Pacific Ocean Exploration Lecture Series, Long Beach, CA.

Jonathan Beaudoin, Briana Welton, Invited, September 18, Development of an Inter Sonar Calibration Field Procedure Using Reson 7125s, Teledyne RESON, Teledyne RESON Underwater Technology Seminar, Copenhagen, Denmark.

Thomas Butkiewicz, Chris Englert, Contributed, September 26, Designing Improved Sediment Transport Visualizations, IEEE MTS, Oceans 2013, San Diego, CA.

Larry Mayer, Invited, September 30, Law of the Sea and Mapping the Extended Continental Shelf in the Arctic, Roger Williams School of Law, Bristol, RI.

Larry Mayer, Invited, September 30, Law of the Sea and Mapping in the Arctic (and elsewhere), Naval War College, Arctic Studies Group, Newport, RI.

Larry Mayer, Invited, October 13, Law of the Sea and Mapping the Continental Shelf in the Arctic, Arctic Circle Assembly, Reykjavik, Iceland.

Larry Mayer, Invited, October 13, Deepwater Horizon and the Arctic—An Academic Practitioner's Perspective, Arctic Circle Assembly, Reykjavik, Iceland.

Larry Mayer, Invited, November 5, U.S. Bathymetric Mapping and Sampling Activities in the Arctic, Arctic V Meeting, Stavanger, Norway.

Jenn Dijkstra, Contributed, November 7, Facilitation of native and non-native species by intermediate foundation species, Coastal and Estuarine Research Foundation Conference, San Diego, CA.

Jonathan Beaudoin, Paul Johnson, Contributed, November 18, Multibeam Advisory Committee Breakout Session, Research Vessel Technical Enhancement Committee, UNOLS RVTEC Meeting, College Station, TX.

Val E. Schmidt, Invited, December 5, Challenges to AUV Operations for Hydrographic Surveys / Optimizing Bathymetric Sonar Systems, Bluefin Robotics, Quincy, MA.

Brian Calder, Contributed, December 17, Risk Models for Hydrographic Applications, International Hydrographic Organization Data Quality Working Group, IHO/DQWG-7, Fredericton, NB, Canada.

# **NOAA Ship *Rainier* Kongsberg Maritime EM710 Multibeam Echosounder Survey System Review & Troubleshooting**

June 7<sup>th</sup>, 2013, rev. 2



J. Beaudoin  
Center for Coastal and Ocean Mapping  
University of New Hampshire  
Durham, NH, USA

G. Rice  
Integrated Ocean and Coastal Mapping Center  
University of New Hampshire  
Durham, NH, USA

B. Foster, K. Hart  
CARIS  
Fredericton, NB, Canada

## Table of Contents

<b>INTRODUCTION .....</b>	<b>3</b>
REVIEW OF BATHYMETRIC ARTIFACTS .....	3
PROPOSED SOLUTIONS AND ADDITIONAL TESTING.....	4
REPORT OVERVIEW.....	4
<b>SYSTEM OVERVIEW AND ANCILLARY INSTRUMENTATION.....</b>	<b>5</b>
<b>VESSEL GEOMETRY.....</b>	<b>6</b>
DOCUMENTATION REVIEW .....	6
RECOMMENDED SETTINGS .....	7
<b>CALIBRATION.....</b>	<b>8</b>
PATCH TEST.....	8
ATTITUDE TIMING.....	9
<i>Option 1: Application in post-processing.....</i>	<i>9</i>
<i>Option 2: Application in real-time.....</i>	<i>10</i>
<b>ACCURACY TESTING.....</b>	<b>11</b>
RELATIVE ACCURACY.....	11
ABSOLUTE VERTICAL ACCURACY.....	16
<b>WORKFLOW VERIFICATION .....</b>	<b>19</b>
<b>CONFIGURATION MODIFICATIONS .....</b>	<b>21</b>
SOFTWARE INSTALLATION: WATER COLUMN DATA LOGGER.....	21
SEABED IMAGERY ACQUISITION .....	21
DATAGRAM DISTRIBUTION .....	22
<b>SUMMARY .....</b>	<b>23</b>
RECOMMENDATIONS.....	24
<b>REFERENCES .....</b>	<b>27</b>
<b>APPENDIX A: TRUEHEAVE ARTIFACT DETAILS.....</b>	<b>28</b>
<b>APPENDIX B: CORRESPONDENCE WITH KONGSBERG MARITIME.....</b>	<b>29</b>

*Cover: NOAA Ship Rainier in Gut Bay, AK. Photo courtesy of ENS D. Manda.*



## Introduction

NOAA Ship *Rainier* is equipped with a Kongsberg Maritime EM710 multibeam echosounder (MBES) and an Applanix POSMV 320 position and orientation system. The survey system aboard the vessel, though showing every indication of being correctly integrated, has been consistently producing bathymetric data of poor quality in higher sea states since the ship had the system installed in late 2010.

It is the intent of this report to: (1) provide an introductory summary of troubleshooting activities done to date by the authors, along with principal findings from these activities, and (2) to document the outcome of additional activities conducted by the authors during a visit to the ship in May of 2013 during mapping operations in the vicinity of Chatham Strait, AK.

## Review of Bathymetric Artifacts

Investigations by Beaudoin in early 2012 indicated that the artifacts were consistent with those associated with heave and/or pitch lever arm errors. Further investigation by Beaudoin found that:

1. The location of the vessel's center of rotation was not configured in the POSMV; this can lead to directionally dependent heave artifacts (Applanix, 2005; p. 2-38).
2. The heave bandwidth setting was set too low for open ocean conditions in the Pacific Northwest; it was configured as 15 sec but should be 20 sec (Applanix, 2005; p. B-18).
3. Applanix TrueHeave could not be successfully be applied in post-processing using CARIS HIPS; at the time, the reason for this was unknown.

Items (1) and (2) were corrected early in the 2012 field season, however there remained the uncertainty associated with the inability to successfully apply TrueHeave in CARIS HIPS, this last problem being the dominant source of sounding error. CARIS HIPS provides two methods for the application of TrueHeave: during sound velocity correction and during Merge. Motion artifacts were seen when applying TrueHeave both during sound velocity correction or during Merge (with no re-SVC) in CARIS HIPS. More puzzling was the fact that TrueHeave could be successfully applied in post-processing by J. Beaudoin using UNB/OMG SwathEd software. TrueHeave could also be correctly applied in SAIC's *Saber* software, as confirmed by S. Byrne of SAIC. This indicated that the EM710 system was acquiring reasonably correct data, albeit still suffering from deficient real-time heave corrections, and that the TrueHeave problem was associated with post-processing in CARIS HIPS. It should be noted that after application of TrueHeave in SwathEd and Saber, Beaudoin and Byrne both found residual data artifacts consistent with a

small motion time delay (~10 ms) along with some evidence of a crosstalk related error, both of these causing roll-type wobbles in higher sea states.

Returning to the problem of applying TrueHeave in CARIS HIPS, it was eventually determined in discussions between CARIS and Kongsberg in May, 2013 that the Kongsberg Sound Velocity Correction (SVC) module does not correctly deal with the situation of reverse mounted transmit (TX) or receive (RX) arrays as is the case on *Rainier*. The Kongsberg SVC module is available via a license only to CARIS HIPS users (like NOAA) with Kongsberg sonars. It becomes the default configuration - the software detects the sonar type and the license for the module and uses it automatically during SVC instead of the native CARIS/UNB SVC module. Additionally, due to a software bug related to Kongsberg systems in CARIS HIPS, it is necessary to use SVC to apply TrueHeave when the POSMV reports heave at a location other than the multibeam transducer; refer to Appendix A for a more detailed discussion on this. Therefore, in CARIS HIPS use of the default configuration for SVC with the Kongsberg module OR the application of TrueHeave outside of SVC (the Merge Process) would both result in the incorrect application of TrueHeave with *Rainier* data and perhaps other artifacts as well. Kongsberg is aware of this limitation of the SVC module and is currently investigating a correction. CARIS is also aware of the software bug and is addressing the issue in an upcoming release.

## Proposed Solutions and Additional Testing

Given that it will take some time for CARIS and Kongsberg to address the SVC problems, it is desirable to immediately provide a workflow that allows for application of TrueHeave in post-processing for *Rainier's* EM710 such that data quality can be improved for the 2013 field season. To this end, the vessel sensor geometries have been reconfigured with the transmitter of the EM710 as the reference point for both the EM710 and the POSMV. This means that both the lever arms and sensor rotations have been entered in the POSMV, such that all real time and logged data is in the ship's reference frame with the EM710 transmitter as the origin.

Moving the reference point in the POSMV to the EM710 transmitter results in a post-processing configuration that requires no additional corrections for sensor angular or linear offsets. This simplifies TrueHeave application, SVC processing, and applying ellipsoid heights, such that all processing workflows in CARIS, using either the Simrad or CARIS SVC module, produces better quality results.

## Report Overview

The activities conducted during the ship visit were:

1. Reconfigure the sensor geometry, as outlined above.

2. Conduct a patch test and update sensor geometry configurations accordingly.
3. Verify the relative and absolute accuracy of the newly configured system.
4. Plan and conduct operations to examine residual data artifacts, if present.

This report serves to document for the surveyors on the ship the exact nature of the configuration changes, along with the results of verification activities to provide evidence that the vessel can continue to provide data of quality expected of a hydrographic survey vessel. Further troubleshooting analysis activities are ongoing and results are not available at this preliminary stage. Though additional data were acquired to address residual artifacts, they are not discussed in this report as it was felt that having a conclusive report for the items listed above in a timely manner was important to support the ship's ongoing mapping activities.

## System Overview and Ancillary Instrumentation

The EM710 frequency range spans 73-97 kHz; the system aboard *Rainier* is capable of 0.5°x1.0° transmit and receiver angular resolution, respectively. The EM710 system is well suited for continental shelf mapping with maximum coverage being achieved at depths typically between 500-1,000 m. Maximum depth performance is typically less than 2,000 m.

The EM710 system allows for seafloor mapping over a swath of 140°, giving a roll stabilized coverage up to 5.5 multiples of water depth (5.5 x w.d.). The system is capable of multiple sector transmission, this allows for pitch/yaw motion stabilization and also multi-ping capabilities. The latter functionality doubles the along-track sounding density and permits surveying at higher speeds without loss of data density. The *Rainier's* system uses the manufacturer's software to configure, monitor and acquire the data, namely Seafloor Information System (SIS), v.3.9.2.

The mapping sensor suite is listed below along with software version numbers where appropriate.

- Kongsberg Maritime EM710 0.5°x1.0° 70-100 kHz multibeam echosounder (MBES), s/n 218; SIS v. 3.9.2 build 187
- Applanix POSMV 320, Ver.4, s/n 3643 positioning and orientation sensor
- Reson SVP70 surface sound speed probe, s/n unknown
- Rolls Royce MVP200 with AML Oceanographic uCTD sensor, s/n 7761; MVP Controller software version 2.430



## Vessel Geometry

The general arrangement of survey system sensors on board NOAA Ship *Rainier* is shown in Figure 1.

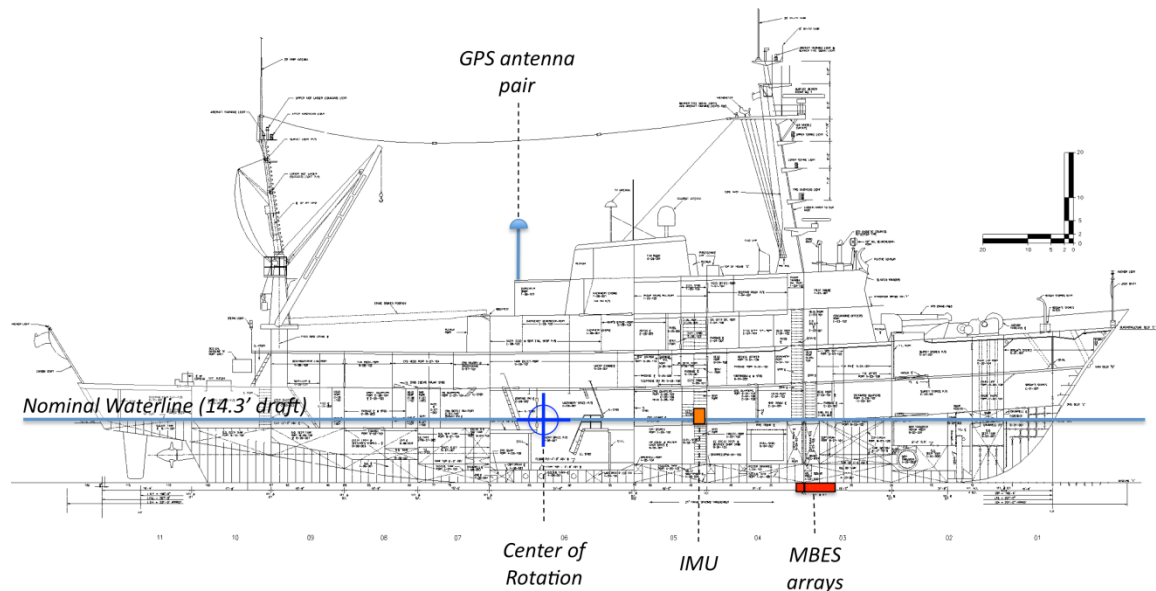

**Figure 1. General arrangement of survey system sensors on board NOAA Ship *Rainier*. Note that the multibeam TX/RX arrays are 0.59 m deeper than keel depth. Draft markings on the hull do not reflect the increase in draft associated with the multibeam gondola.**

## Documentation Review

The ship survey documentation (Westlake, 2010) was reviewed by Beaudoin and Rice with the intent of determining the vessel sensor geometry to be applied. The survey documentation was satisfactory and all sensor locations and angular offsets were readily found with the exception of the angular orientation of the POSMV IMU. It is our understanding that the IMU was not in place during the survey.

The geometry review generated angular and linear offsets that were consistent with the sensor configuration that was in use upon arrival on the ship on 05/25/13. Only slight errors were found in the ship installation and these were corrected (the heading and roll values for the transmit array were from the forward module instead of being the average of the two transmit arrays). It is not felt that these very small errors ( $<0.05^\circ$ ) could have contributed to the various artifacts observed to date.

The survey report expressed the positions of all sensors in a reference frame with the granite block as the origin. The initial survey system configuration incorporated the offsets in the report directly into both the POSMV and the EM710, i.e. both survey systems maintain the granite block as the origin. In the case of the POSMV, the position and orientation that are output/recorded are of the granite block reference point. In the case of the EM710, the sensor locations associated with the motion and position provided by the POSMV are left at the origin since this the location for which these data streams are valid. The only offsets to apply in the EM710 are the locations of the TX and RX arrays and the waterline Z offset (WLZ), all of these being reported relative to the granite block reference point.

### Recommended settings

Given that the application of TrueHeave is not possible due to the limitations of the Kongsberg SVC associated with the reverse mounting of the transmitter and receiver, it is recommended to reconfigure both the POSMV and EM710 to use the transmitter as the reference point. The recommended set of offsets is summarized in Table 1.

**Table 1. Summary of Sensor Linear and Angular Offsets. Information in dark grey rows is input in POSMV configuration, information in light grey rows is input into SIS.**

	+ve fwd	+ve stbd	+ve down	+ve port up	+ve bow up	+ve to stbd
	<b>X (m)</b>	<b>Y (m)</b>	<b>Z (m)</b>	<b>Roll (°)</b>	<b>Pitch (°)</b>	<b>Heading (°)</b>
<b>POSMV primary antenna (port)</b>	-20.110	-1.186	-17.877	-	-	-
<b>IMU</b>	-8.064	-1.860	-4.607	-0.165° **	0.020° **	0.160° **
<b>Center of rotation</b>	-18.284	-0.106	-4.557	-	-	-
<b>EM710 TX</b>	0.000	0.000	0.000	-0.0515° *	0.012° *	179.978°
<b>EM710 RX</b>	-1.5405	-0.1045	0.000	-0.030° *	0.000° *	180.019°
<b>Waterline</b>	-	-	-4.831	-	-	-

*\* Roll/Pitch sign convention is opposite of usual Kongsberg convention due to reverse mounting of TX and RX arrays*

*\*\* IMU rotations were derived from the patch test conducted 2013-05-25. See Calibration / Patch Test on p8.*

In this particular configuration, the POSMV outputs position and orientation, including real-time and TrueHeave, at the transmitter array. These are recorded in the Kongsberg data stream without further corrections. The consistency in the reported location of the heave signals allows for simple application of TrueHeave in HIPS post-processing, either (1) without further SVC corrections (during Merge) or (2) using either Kongsberg or CARIS/UNB SVC.

The POSMV is configured with the EM710 TX array as the origin and the offsets for the primary GPS, IMU and Center of Rotation being reported relative to this location. All other linear and angular offsets are set to zero, e.g. Sensor 1, etc. This configuration forces the POSMV to report position, orientation and heave at the TX array.

The EM710 is also configured to have the TX array as the reference point with the RX array position and waterline Z being reported relative to this location. The position and orientation input from the POSMV are being reported at the location of the TX array, thus the MRU and Positioning offsets are set to zero in SIS.

In this new configuration, waterline measurement procedures must be adjusted to accommodate the change in reference point. The laser range finder procedure remains the same and the same arithmetic can be used to average/correct these readings, however, the EM710 TX z offset of 4.557 must be removed in order to reference the waterline to the TX array since the spreadsheet was designed to report the output relative to the granite block (WLZ<sub>GB</sub>, positive down), i.e.

$$WLZ_{TX} = WLZ_{GB} - TXZ_{GB}$$

For example, given a spreadsheet waterline Z value of -0.26, the value with respect to the TX array would be:

$$WLZ_{TX} = -0.26 - 4.557 = -4.817$$

The spreadsheet that is used for WLZ recording and calculation was updated with the Operations Officer to accommodate the new configuration.

## Calibration

### Patch Test

After reconfiguration of the survey system geometry in the POSMV and SIS, angular offset values for the POSMV IMU were estimated via a patch test in the general vicinity of Cape Ommaney, AK. Pitch and heading offsets were determined in 145 m of water over a series of bedrock outcrops and the roll offset was determined over a



flat seafloor in 550 m water depth. Offsets were assessed independently by Beaudoin and Rice using UNB/OMG SwathEd and CARIS HIPS, respectively. These were applied in the POSMV configuration as an IMU to reference frame angular offset. The signs of the patch test results were changed to accommodate the fact that the patch test offsets are being applied to the IMU and not the MBES:

Roll:  $-0.165^{\circ}$   
Pitch:  $0.02^{\circ}$   
Heading:  $0.16^{\circ}$

Confirmation lines were run to verify the offsets. The data were also re-processed using the SBET position to improve confidence in their assessment with these secondary evaluations confirming the first set. If at any point these offsets are migrated elsewhere in the POSMV or SIS configuration, the signs of the above values should be reversed.

### Attitude Timing

Effort was dedicated to further investigating the previously mentioned time delay in the POS MV motion serial feed. Blind testing using 1 ms increments of time delay to produce bathymetry imagery in post-processing determined a time offset between 11 ms and 17 ms. A value of 14 ms was entered into SIS for the serial feed for the remainder of the trials. Under this configuration, the EM710 TRU applies the time delay to the soundings in real-time, and then SIS writes out the motion time series with the time delay applied such that post-processing does not require application of the time delay (essentially, the time stamps of the motion time-series are corrected prior to being written to disk). This was confirmed via email with the manufacturer (see Appendix B) and was independently verified in both CARIS HIPS and UNB/OMG SwathEd software.

Follow up post-processing using POSMV data files (.000) and SBET data files (.sbet) for motion correction indicated that the time-delay correction is required when using these data files for the source of orientation information, thus there are two options for addressing the motion time series time-delay: (1) complete application in post-processing and (2) hybrid real-time/post-processing application. It is up to the ship to decide what works best for their particular situation and workflow. Note that the ship was left with the real-time application configuration at the end of the trials, however, the SBET/TrueHeave import work-around had not yet been explored.

### Option 1: Application in post-processing

In this configuration, the time delay is not applied in real-time in SIS. The same motion time-delay is thus present in the .all files AND the SBET files AND the

TrueHeave files. A single HVF file will serve post-processing for all data files. The drawback of this approach is that data MUST be post-processed for SVC corrections and the real-time gridding engine in SIS becomes less effective as a real-time QA tool.

If this configuration option is desired, then the following changes must be made to the systems and/or post-processing workflow:

- 1) The 14 ms time delay must be removed from the motion sensor input configuration in the “Installation Parameters” menu in SIS.
- 2) A 14 ms time delay must be configured for the POS MV in the CARIS HVF. The time tag of this change should match the date/time that SIS was reconfigured for (1) above.

### Option 2: Application in real-time

In this configuration, the EM710 TRU is configured to apply the time-delay in real-time. Though the TRU cannot correct the beam roll stabilization for the delay, the residual roll error associated with the delay can be applied during the sounding reduction process that generates the corrected soundings used for real-time gridding. This has the advantage of enabling the operator to use the real-time gridding display as a QA tool to help recognize, diagnose and rectify other problems in real-time, for example, an inadequate sound speed profile. For a workflow that seeks to minimize post-processing, this also has advantages since the soundings do not require additional SVC processing to apply the time delay corrector.

The disadvantage of this approach is that the time systems of the data recorded natively by the POSMV (.000) do not match that of the data recorded by SIS (.all). If POSMV data are applied in post-processing (either TrueHeave or SBET) then a time-delay will be required to bring these data into alignment with the Kongsberg data. This can be addressed by applying a 14 ms time delay to the TrueHeave and/or SBET data during the Load stage. Note that the time delay is not an entry in the vessel configuration file, it is instead an optional parameter that is applied during the Load procedure, see Fig. 2.

If this configuration option is desired, then the following changes must be made to the systems and/or post-processing workflow:

- 1) SIS should remain configured for the motion time-series time delay. Note that this was the configuration at the end of the trials. NO CHANGE IS REQUIRED.
- 2) During import into CARIS HIPS, TrueHeave and/or SBET data should have a 14 ms time delay applied at the appropriate stage in the import Wizard. SBET data should be limited to latitude, longitude and GPS height. SOP documentation should be updated to reflect this change.

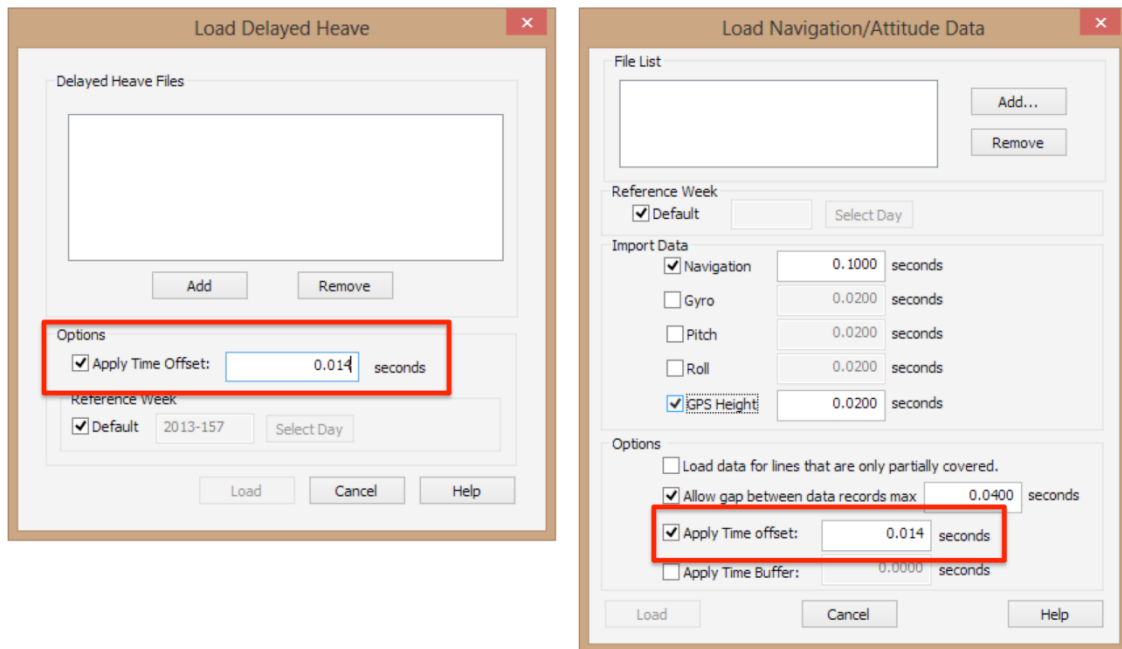

Figure 2. TrueHeave and SBET import wizard configuration for applying a time delay.

## Accuracy Testing

### Relative Accuracy

After the patch test calibration procedures, a relative reference surface was created by acquiring EM710 data in 550 m water depth over an area measuring approximately 2.4NM x 1.5NM with 5 survey lines spaced 1 water depth (w.d.) apart with a ship speed of 6 kts. Prior to acquisition, a deep MVP cast was acquired and applied in SIS. The MBES was configured as follows:

- DEEP mode
- Angular sector limited to +/-60°
- Dynamic dual-swath
- FM disabled
- Pitch and yaw stabilization enabled

After swath editing the data, a 5 m bathymetric grid was created using an inverse distance weighted gridding scheme with a projected beam footprint radius of influence for each sounding and swath angle beam weighting. Predicted tides from Port Alexander, AK (Station ID: 9451054) were applied.



Two crosslines were run over the reference surface at a speed of 6 kts, both in DEEP mode, the first pass had FM enabled and the second had FM disabled. Beam depth bias statistics were compiled by differencing the crossline soundings against the reference surface, taking care to exclude areas where seafloor slopes exceeded 5°. Results are shown in Figs. 3 through 6 below.

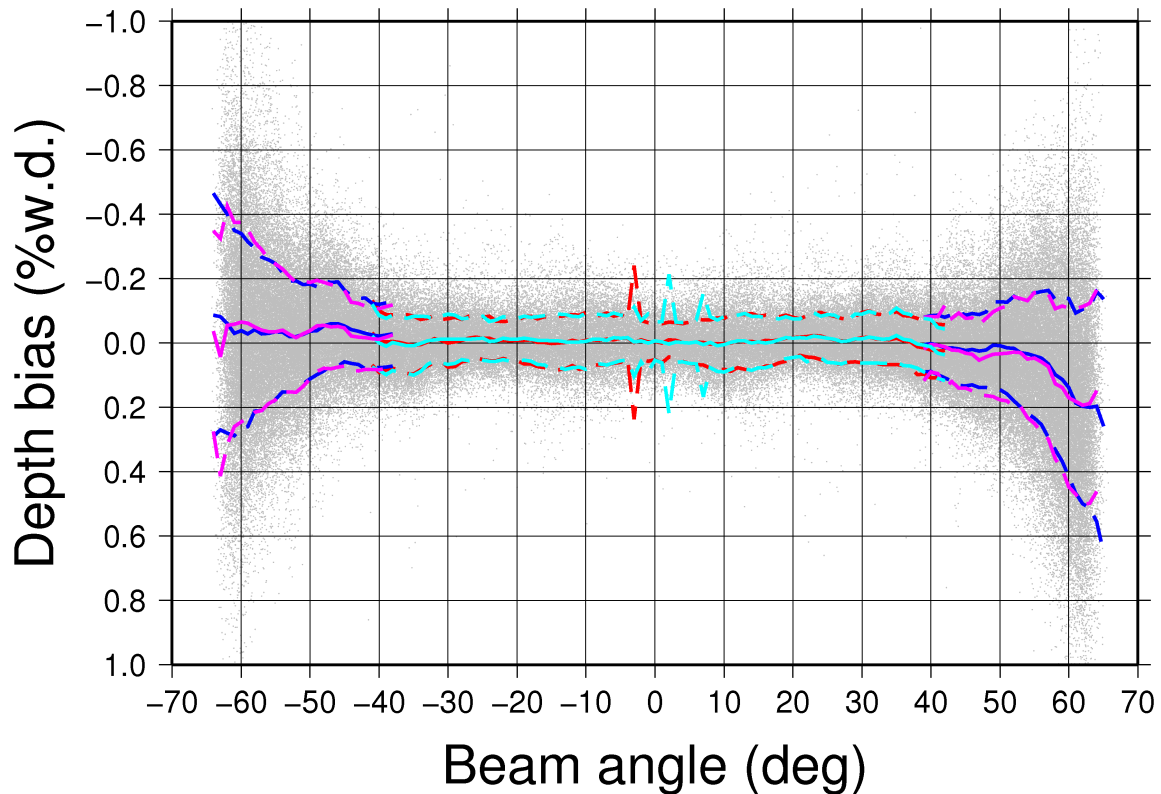

Figure 3. Scatter plot of beam depth biases with respect to the relative reference surface for DEEP CW mode. The mean and standard deviation is computed in 1° bins across the swath with the mean plotted as a solid line and the standard deviation (1- $\sigma$ ) plotted as dashed lines. Color-coding corresponds to the transmission sectors, alternating in red-blue or magenta-cyan across the swath. Red-blue indicates data from the first swath of the dual-swath geometry and magenta-cyan is for the second swath of the dual-swath geometry. The mean bias is negligible across the majority of the swath with the exception of the outer 15° on the starboard side (positive angles).

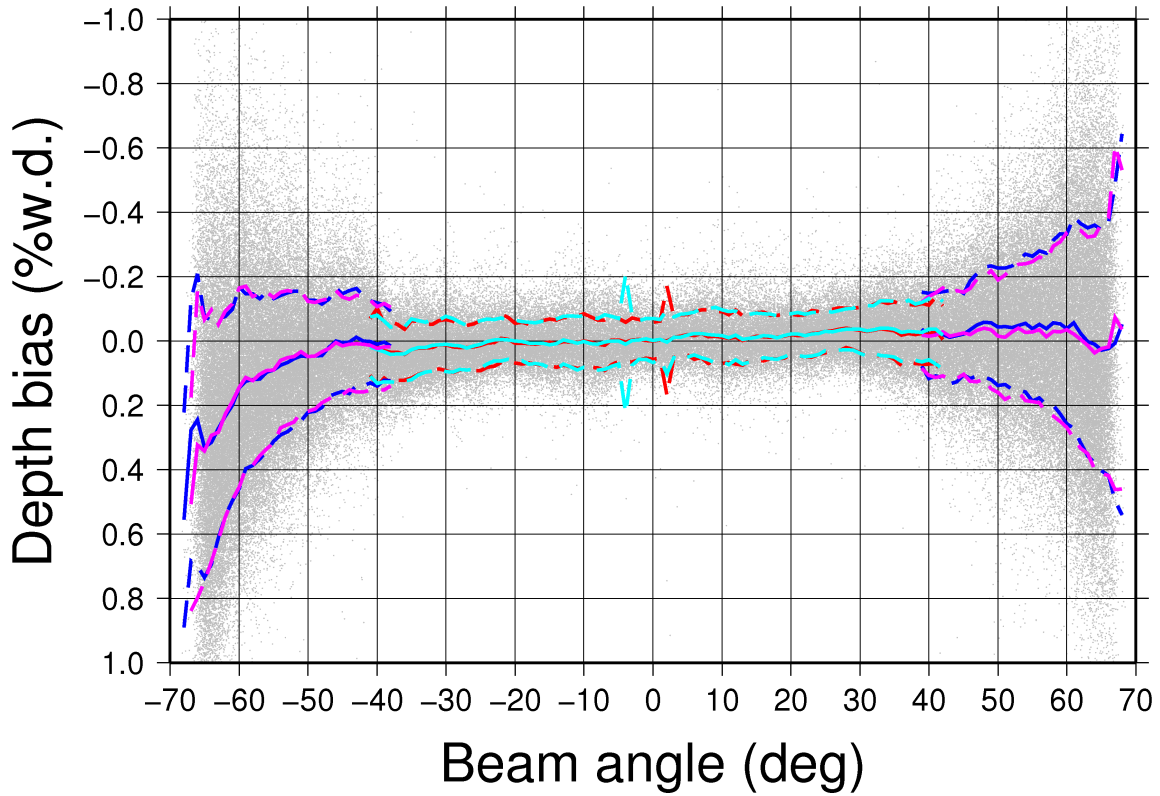

Figure 4. Scatter plot of beam biases with respect to the reference surface for the DEEP FM mode. The color coding scheme is the same as the DEEP CW mode show in Fig. 2. Note that the system achieved more coverage due to the use of FM waveforms in the outer sectors. The refraction like curl artifact observed on the starboard side has shifted to the port side. The magnitude of the artifact is similar to that observed in the CW pass however greater biases are observed due to the increased achievable angular sector.

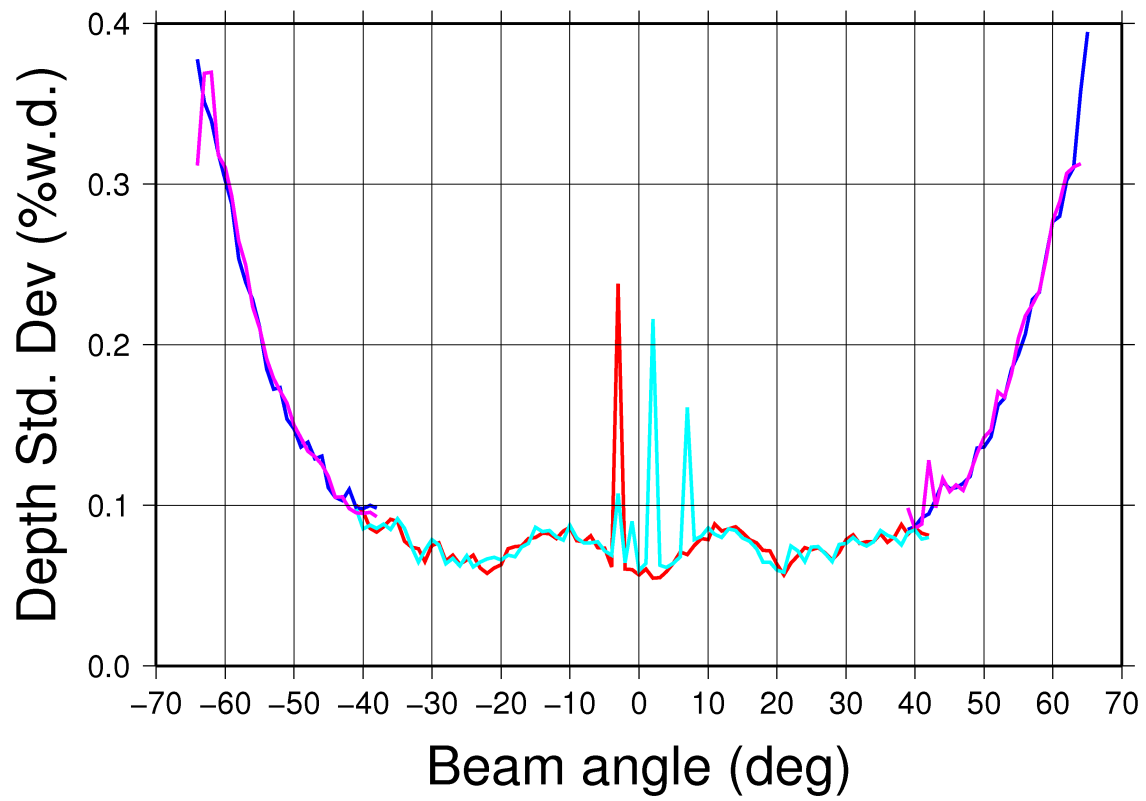

Figure 5. Standard deviations across the swath for DEEP CW mode. Color coding is the same as in Figs. 3 and 4.



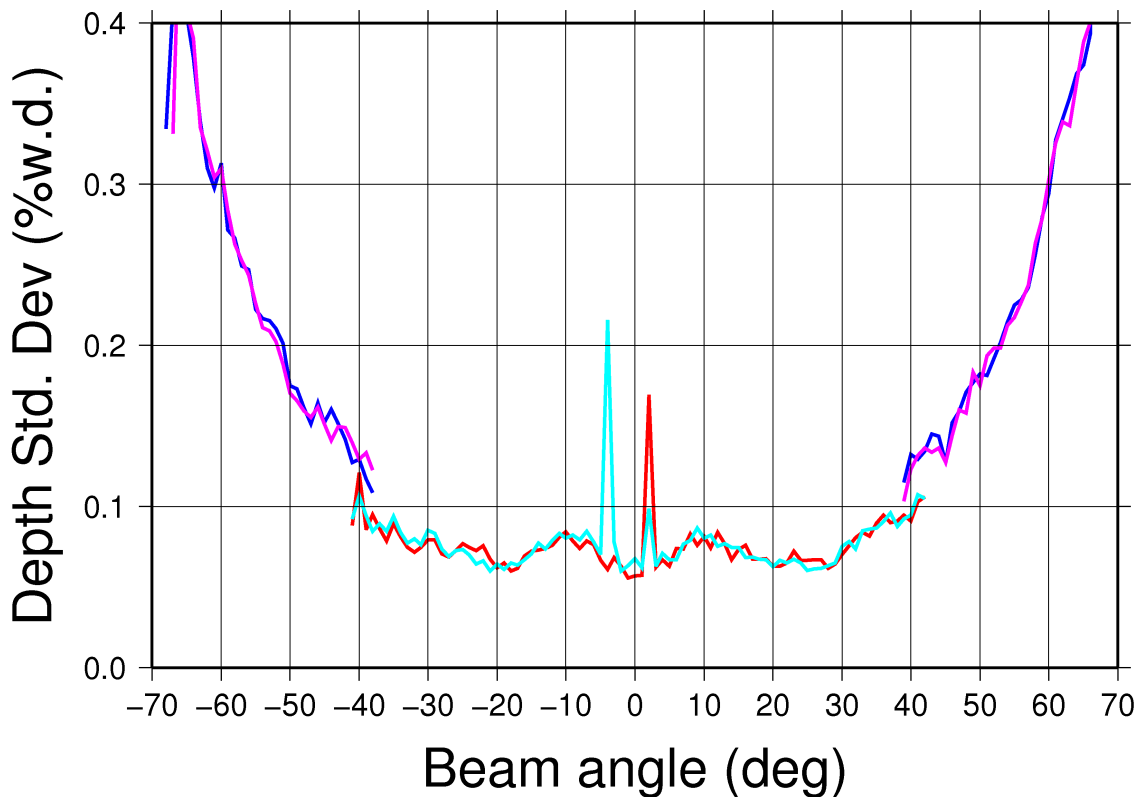

Figure 6. Standard deviations across the swath for DEEP FM mode. Color coding is the same as for Figs. 3 through 5.

The observed mean biases and standard deviations are consistent with those observed on a similar EM710 system on R/V *Falkor* (Beaudoin et al., 2012/2013). Both passes show beam depth biases less than 0.05% w.d. across the majority of the achievable swath with small residual refraction-like artifacts in the outer portions of the swath. The crossline statistics highlight a slight directional dependence to the mean bias with a slight refraction artifact being observed in the outermost sector corresponding to the side of the vessel facing to the east. The crosslines were acquired in the north-south direction at a speed of 6 kts and crabbing of  $\sim 5^\circ$  was observed in both directions due to a westerly current. The same effect is observed in both passes though it appears more pronounced in the FM pass due to its ability to sound over a larger swath due the increased range performance associated with the use of FM pulses. Yaw stabilization was configured to stabilize based on mean relative heading (instead of the survey line heading), thus aggressive yaw stabilization cannot be blamed since the mean heading remained more or less constant throughout the line regardless of the crabbing. This same crabbing related effect has been observed in recent evaluations of R/V *Falkor*'s EM710 and EM302 systems (Beaudoin et al., 2013). Given the directional dependence and consistency of the artifact with the direction of the current, this effect is likely environmental.

Despite the excessive crabbing due to strong current, the sea state was minimal during this testing and further testing must be done to evaluate whether or not the bathymetric data are being adequately corrected for motion and orientation.

It should be pointed out that these results were for a deep water test. Similar testing can be done for other system modes, e.g. SHALLOW, MEDIUM. It is our understanding that the EM710 is assigned to map areas deeper than 200 m and that areas shallower than this are typically mapped with the Reson 7125/8125 systems on the ship's launches. The system should be tested in MEDIUM mode at the very least since MEDIUM mode is meant for use in 200 to 300 m of water.

### **Absolute Vertical Accuracy**

The accuracy tests described earlier indicate that the system is correctly integrated, however, they do not assess the absolute vertical accuracy. For this purpose, ship data were acquired on day 147 in the approaches and entrance to Gut Bay, AK in order to compare against data acquired by Launch 2804's Reson 7125 MBES (collected on day 143). Predicted TCARI tides were applied to both the launch and ship data. The area of overlap between ship and launch data spanned depths of 12 m to 60 m. As shown in Figs. 7 through 9, there is excellent agreement between launch and ship data. This confirms that the EM710 and POSMV sensor geometry reconfiguration has been done successfully.

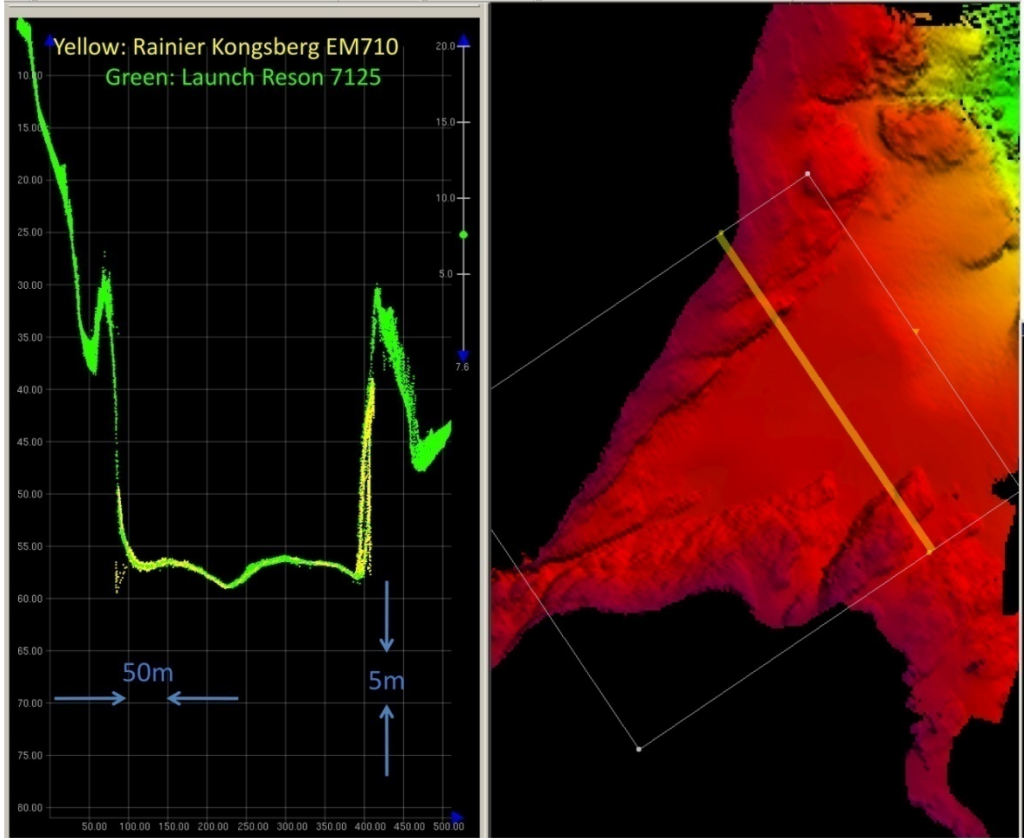

Figure 7. Rainier EM710 and Launch 7125 data comparison, subset #1.



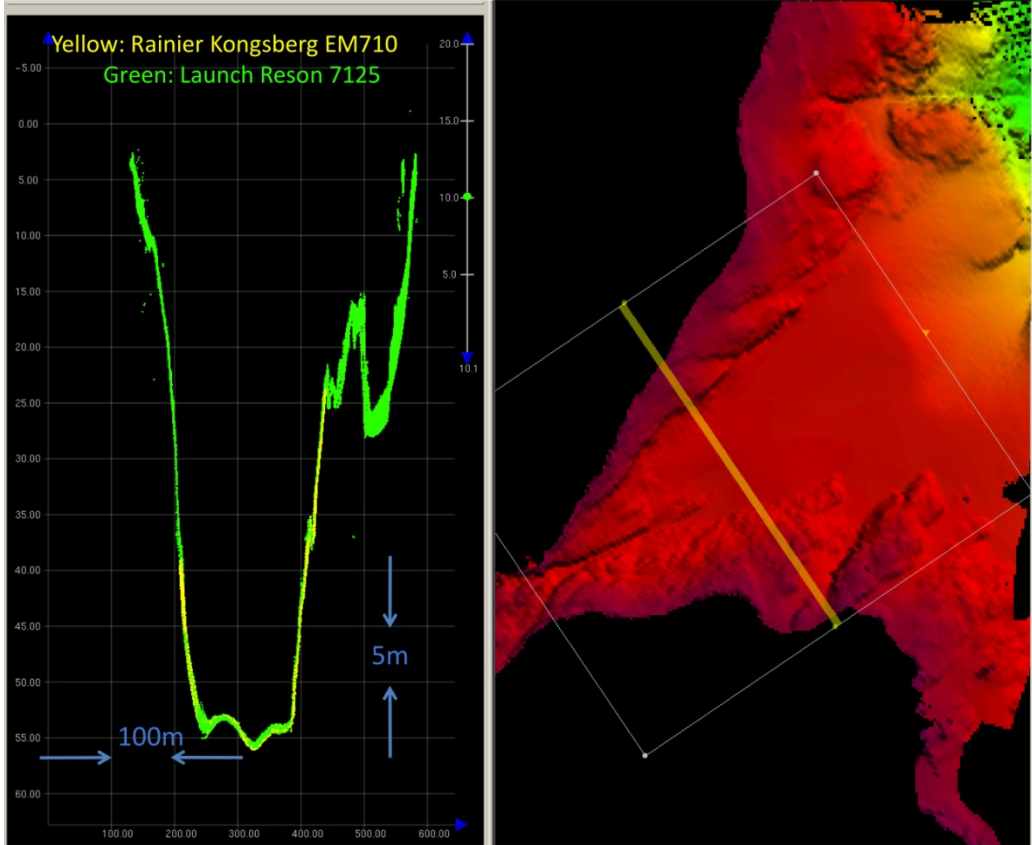

Figure 8. Rainier EM710 and Launch 7125 data comparison, subset #2.

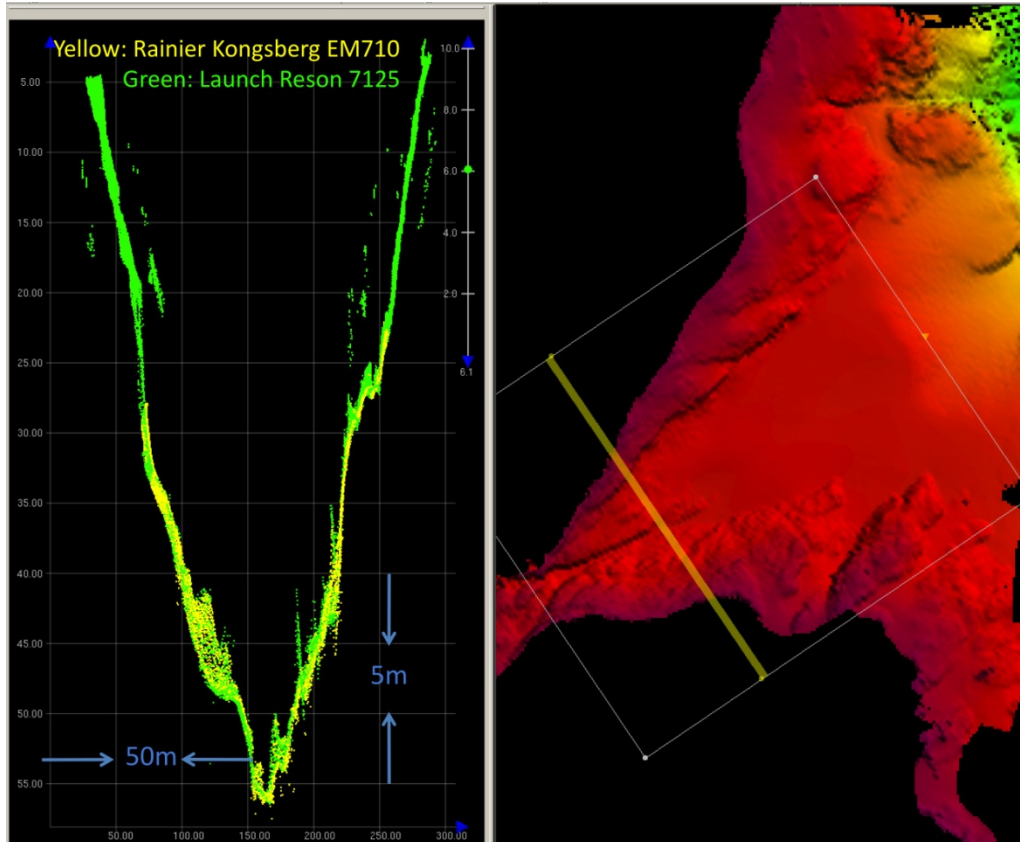

Figure 9. Rainier EM710 and Launch 7125 data comparison, subset #3.

## Workflow Verification

Effort was made to leave the ship with a workflow that would provide the most familiar and flexible path for all products. Difficulties with the previous POS MV and EM710 configuration limited the application of TrueHeave, as well as post processed position, attitude and ellipsoid height. CARIS HIPS, the normal post processing software used aboard NOAA ship *Rainier*, can provide two workflows for performing sound speed correction (SVC). SVC is where new vessel configuration or navigation is applied. One workflow uses an SVC module provided by Kongsberg, but a second uses the native SVC within CARIS HIPS.

With the new POS MV and EM710 configuration either SVC module may be used. The data used in this process was collected in an exposed location, and the ship did encounter motion as shown in Fig. 10. Application of only TrueHeave, application of TrueHeave after SVC correct were both tested through both SVC modules. SBETs were created through Applanix POSpac and loaded into CARIS to provide post processed attitude, navigation, and vessel height relative to the ellipsoid. These data

were also successfully applied through either SVC module. See Fig. 11 for examples of the different workflow results.

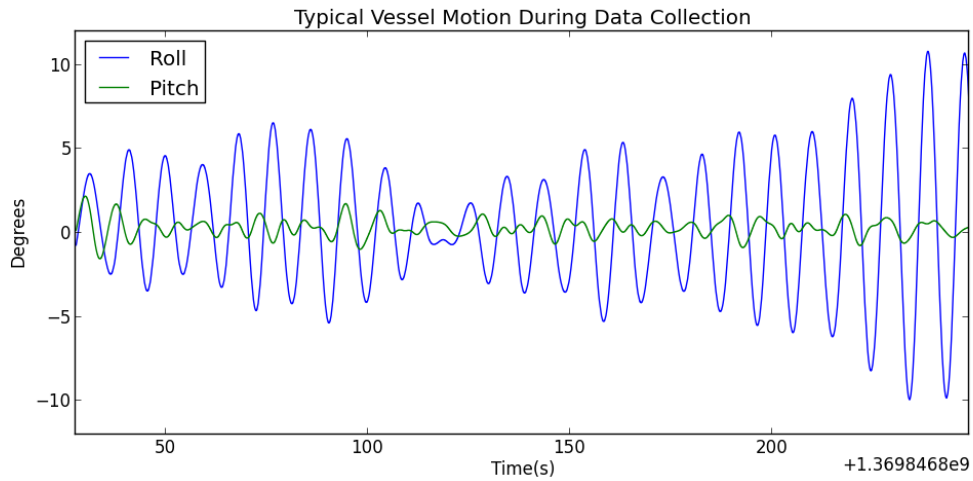

Figure 10. Typical roll and pitch during data collection for workflow testing.

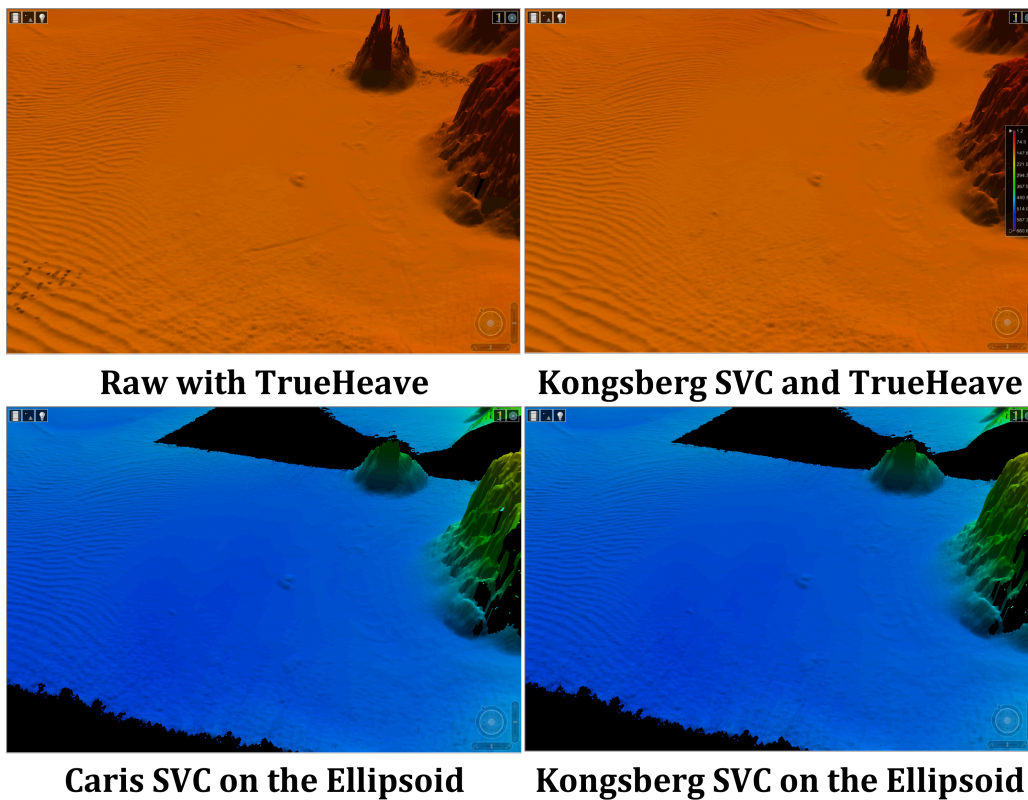

Figure 11. The results of four different processing approaches, demonstrating a common quality of result for both SVC modules and with data to the ellipsoid. One meter ripples are unobscured by any data artifacts in approximately 120 meters of depth.



## Configuration Modifications

Minor miscellaneous system reconfigurations were completed during the ship visit. These are documented in this section.

### Software Installation: Water Column Data Logger

A water column data logger was written and installed on the MVP computer. The logger, which is experimental, logs the water column data along with the typical datagram set found in a “.all” file via a datagram subscription to SIS (see the Datagram Distribution section below for details on the distribution mechanism and configuration). The logger is run by double-clicking the wcLogger.py shortcut on the MVP computer desktop. This will record a file named “test\_YYYYMMDDHHMMSS.all” file in the wcLogger folder on the Desktop where the filename is updated with the current date and time. The output file was successfully tested in *UNB/OMG SwathEd*, *CARIS HIPS* and *QPS FM Midwater*.

It should be noted that this experimental data logger is meant for intermittent use only: it will log indefinitely and can potentially create many large files if left unattended. The water column datagram will only be broadcasted if the water column display is shown in SIS. This requirement only applies to the water column logger and does not apply if SIS is licensed to record water column data on its own.

### Seabed Imagery Acquisition

The “sector tracking” filter was disabled in the SIS Runtime Parameters under the “Filters and Gains” tab. This filter corrects the seabed imagery for inter sector beam pattern imbalances using an adaptive filter, however, this is done in a non-recoverable fashion that can impede quantitative analysis of seabed imagery in post-processing. It is recommended that this filter be disabled.

The CastTime software was updated remotely on request by Matt Wilson to handle the “S12” datagram protocol from the MVP such that temperature and salinity values can be sent to the EM710 for improved backscatter data quality. Three modifications to ship software systems were done to accommodate this development:

1. The MVP software network transmission protocol was modified to transmit “S12” data. It is understood that this was the original configuration prior to Wilson’s visit to the ship in early 2013.
2. The SVP Editor software configuration file was modified to accept “S12” incoming data from Wilson’s CastTime software.
3. The EM710 “Filters and Gains” menu was changed to allow for CTD computation of the absorption coefficient.

## Datagram Distribution

The distribution of various datagrams from the EM710 was modified to accommodate the water column data logger and also to ease the workload of the SVP Editor by providing a dedicated stream of the few datagrams that it requires (as opposed to the entire datagram set that was being sent to Hypack and SVP Editor via the DataDistrib.exe utility). Figs. 12 and 13 provide detailed information on the configuration changes.

The screenshot shows a window titled "Request datagrams from EM" with the following fields: Echosounder (EM710\_218), Datagram (Position (P)), Options (All), and IP:Port. Below these are "Subscribe" and "Unsubscribe" buttons. A message states "Please restart SIS for changes to take effect".

Datagram	IP:Port	Interval
Information	localhost:9004	All
Information	localhost:4002	All
Motion sensor	localhost:4002	All
Clock	localhost:4002	All
Depth	localhost:4002	All
Installation	localhost:9004	All
Position	localhost:16108	All
Position	localhost:9004	All
Position	localhost:9009	All
Position	localhost:4002	All
Position	HDPc:5052	All
Runtime	localhost:4002	All
XYZ88	localhost:4002	All
Height	localhost:4002	All
Watercolumn	localhost:16102	All
Watercolumn	localhost:16203	All
Position	localhost:16303	Every second
XYZ88	localhost:16303	Every second
Sound speed profile	localhost:16303	All

Annotations in the image:

- "SIS default internal datagram distribution, do not modify!" points to the first "Position" entry (localhost:9004).
- "Modifications by J. Beaudoin 2013-05-28" is written in orange text.
- "Watercolumn logger, port 16203" points to the "Watercolumn" entry at localhost:16203.
- "SVP Editor, port 16303" points to the "Position" and "XYZ88" entries at localhost:16303.
- "These datagrams are distributed locally to ports on the SIS computer" is enclosed in a box around the last four rows of the table.

Figure 12. Datagram subscription interface indicating the datagram subscriptions that were added during the ship visit. These datagrams are distributed locally on the SIS machine to two separate ports and the DataDistrib.exe utility provided by Kongsberg is used to re-distribute these to the appropriate computer, in this case to the MVP computer.

Source Port	Source File	Packets	Destination : Port	Destination : Port	Destination : Port	Destination : Port	Destination File
4310		11399	192.168.0.3:4002				Data feed #1
16103		528752	192.168.0.5:5000	192.168.0.3:16203			Data feed #2
16203		320358	192.168.0.3:16203				Data feed #3
16303		10699	192.168.0.3:16103				Data feed #4
0		-1					
0		-1					
0		-1					
0		-1					
0		-1					
0		-1					
0		-1					

MVP: 192.168.0.3  
Hypack: 192.168.0.5

Ver 1.1.0.14

- Data feed #1:** Provides depth detection from EM710 to MVP computer for bottom avoidance
- Data feed #2:** Provides EM710 bathy, position and orientation data to Hypack computer; provides same data to Watercolumn Logger on the MVP computer
- Data feed #3:** Provides watercolumn datagram to Watercolumn Logger on MVP machine
- Data feed #4:** Provides depth, position and SVP to SVP Editor on MVP machine

Figure 13. Configuration of the DataDistrib.exe utility. Data feeds #1 and #2 existed upon arrival. Datagram feeds #3 and #4 were added by J. Beaudoin during the ship visit to accommodate the Watercolumn Logger and the SVP Editor, both on the MVP computer. The data stream fed to Hypack (#2) is split to allow for recording of a full datagram dataset by the Watercolumn Logger such that these files can be processed in a standalone manner without the data files recorded by SIS.

## Summary

Sensor geometry reconfiguration was successfully completed and tested on Rainier and a 14 ms orientation time delay was applied in SIS to accommodate an observed latency in the transmission of motion data from the POSMV to SIS. We feel that these two modifications will improve the data quality with the geometry reconfiguration allowing for successful application of TrueHeave in post-processing and the time-delay configuration improving the data quality of soundings as corrected in real-time by SIS. Minor changes to TrueHeave and SBET importing into CARIS will allow for application of the time delay such that the POSMV and SIS data streams are synchronized.

Whereas it was not possible to test the survey system as a whole in high pitch conditions, we feel that these configuration changes will allow for field personnel to conduct additional troubleshooting if necessary without residual artifacts being masked by the problems associated with applying TrueHeave. Given the limited sea state in which we could test the system during the ship visit, it is possible that



residual artifacts remain to be explored. Given the severity and nature of residual artifacts observed by both Beaudoin and Byrne in separate data reviews of 2012 field season data, we cannot confidently claim that we have fully resolved ALL problems associated with *Rainier's* mapping systems. This being said, we feel that the configuration changes made to the ship's systems will allow all investigators, including ship personnel, to undertake troubleshooting activities on the same footing. This will hopefully allow for a quick resolution of residual problems, if there are any.

Additional data were collected in various configurations to explore the potential causes of residual artifacts, however, these are not examined in this report. Future findings from these data sets, if any, will be reported in a timely manner to ship personnel and will also be communicated to the manufacturer.

## Recommendations

### **SVC Post-Processing**

It is still unclear on the exact nature of the deficiencies associated with the Kongsberg DLL SVC algorithm. We feel that the geometry reconfiguration may work around the problems in post-processing but we cannot be sure of this given the proprietary nature of the Kongsberg SVC DLL as licensed to CARIS. Given this potential limitation, it is preferable to maintain the use of the UNB SVC method. It should be noted that the UNB method has limitations which will introduce data artifacts at sector boundaries under conditions of aggressive helming with yaw stabilization enabled and in very shallow water were the transmitter and receiver separation is a non-negligible fraction of the water depth.

### **Upcoming 2013 ship survey**

A potential source of uncertainty in linear and angular sensor offsets is misinterpretation of ship survey results due to differences in coordinate frame and rotation conventions. As the surveyor's customer, one should not have to spend time reviewing a surveyor's report to find the required values and converting them into the desired coordinate frame. For the upcoming 2013 ship survey, it should be clearly communicated to the providers of the vessel survey that the linear and angular measurements should be reported in a coordinate frame that allows for direct application of surveyed offsets. The Kongsberg and Applanix coordinate frame is, luckily, consistent and can be used to direct the surveyor on what is desired in the survey report:

- X-axis: positive in the forward direction
- Y-axis: positive in the starboard direction
- Z-axis: positive in the downward direction

- Roll: positive roll about the x-axis brings the port side up and starboard side down
- Pitch: positive pitch about the y-axis brings the bow up and stern down
- Heading: positive heading about the z-axis turns the bow toward starboard (clockwise looking from above)

This is a right-handed coordinate frame. Of particular importance is the sign convention used for roll and pitch angular offsets.

For consistency with the 2010 survey, it is recommended to use the Granite Block as the origin point of output coordinate frame.

It is recommended to insist that the surveyor provide a tabular summary of desired positions and angular offsets for the sensor offsets as part of an executive summary at the beginning of the survey report for the following positions:

- Granite Block reference point
- EM710 transmitter and receiver arrays
- POSMV IMU
- POSMV GPS antenna mounts and POSMV GPS antenna
- Waterline measurement benchmarks

It is also recommended to record ship POSMV POSPac files throughout the survey to aid in establishment of the IMU orientation with respect to the vessel coordinate frame. In addition, two bench marks aboard the ship should be occupied with GPS base stations to establish a baseline heading relative to the ship's antennas and the IMU.

### **Future Patch Tests**

To remain consistent with the current configuration, the IMU orientation values with respect to the vessel reference frame should be input into the POSMV IMU angular offsets fields (these are currently populated with values determined via a patch test during this ship visit). There are two configurations possible for updating with information from future patch tests.

Future patch tests could leave POSMV IMU angular offsets in the POSMV configuration: these are the "bulk" correctors applied to the IMU angular offsets and the patch test will determine small residual correctors. The values determined by the surveyor will be of much higher accuracy and these would NOT be reset to zero prior to a patch test.

There is great value in being able to quickly verify the POSMV and EM710 installation angles against values documented in the most recent ship survey. This is especially true in work environments with large survey teams with sometimes high rotation or turnover of personnel. The ability to load baseline "master"

configuration files cannot be understated in large survey teams. For this reason, residual patch test correctors would NOT be applied to the POSMV IMU or to the EM710 TX/RX arrays. Preserving the bulk correctors for these sensors in their respective configurations allows for quick and easy verification against the alignment angles determined from the ship survey.

There are other reasons for not applying patch test offsets to the EM710 TX/RX arrays. As the arrays are reverse mounted, applying patch test offsets to the arrays will require a sign reversal. This is additionally complicated by the fact that the operator must add the offset to the existing values (recall that patch test offsets are additive correctors); this exposes the survey system to potential human error.

The first possible configuration applies residual patch tests correctors either in (a) the SIS MRU angular offset fields to be applied in real-time, or (b) in a HIPS vessel configuration file to be applied in post-processing. There are some points to consider for both scenarios:

- Applying in real-time allows for the best possible data quality with minimal post-processing requirements
- Applying in post-processing allows for a clear record of the evolution of patch test offsets over time since the CARIS HIPS HVF file, by design, forces the data processor to time-tag patch test offsets.

If one subscribes to the philosophy of preserving master configuration files for the sensors to aid in survey configuration management, this would argue for the latter approach since the SIS configuration would not need to be updated at all.

A second approach would be to update the POSMV rotation values as provided by the surveyors by subtracting the patch test results. This would keep the Kongsberg and CARIS HVF values as simple as possible, and ensure all rotations and motions corrections are happening from one source. These updates should be made infrequently, documented carefully, and made by experienced personnel only.

Either way, the practice of updating the WLZ values in SIS should be abandoned and these correctors should instead be applied in post-processing. The argument to apply WLZ in post-processing is further strengthened by the date and time-tagging of the WLZ in the HVF: this documents variations in WLZ in a way that is not captured in a readily retrievable manner when these are applied in real-time.



## References

- Applanix (2005). "POS MV V4 Installation and Operation Guide". Applanix Corporation, hardware and software manual, 350 pp.
- Beaudoin, J., Johnson, P., Lurton, X. and Augustin, J.-M. (2012). "R/V Falkor Multibeam Echosounder System Review". UNH-CCOM/JHC Technical Report 12-001, Sept. 4, 2012. Report, 57 pp.
- Beaudoin, J., Johnson, P. and Flinders, A. (2013). "R/V Falkor Multibeam Echosounder System Review". UNH-CCOM/JHC Technical Report 13-001, April 2, 2013. Report, 77 pp.
- Westlake (2010). "Report of Measurements: Alignment Support and As-Builting NOAA Rainier". Westlake Consultants, Inc., October 12, 2010. Report, 13 pp.

## Appendix A: TrueHeave Artifact Details

The POSMV, as it has been traditionally configured on *Rainier*, reports heave and TrueHeave at the granite block survey reference point and it makes no correction for the additional heave experienced by the EM710 arrays, nearly 8 m forward of the reference point.

The Kongsberg acquisition system (SIS) receives the POSMV heave and then performs the additional lever arm correction to account for induced heave in real-time. The heave that is recorded in the raw .all file is the heave as experienced at the location of the transmit array, this being the sum of the heave measured by the POSMV at the reference point and the additional induced heave component calculated by SIS. Thus, the heave that is recorded by Kongsberg is not the raw measurement provided by the motion sensor.

The Kongsberg SVC module included in CARIS HIPS has a bug that introduces bathymetric artifacts when the motion output is not coincident with the sonar arrays. Additionally, due to a bug in the current CARIS HIPS software release that applies to Kongsberg sonars only, one must perform a sound velocity correction in order to calculate and add the induced heave component if the TrueHeave is reported at a separate location than the sonar arrays. However, when the TrueHeave is reported at the same location as the sonar arrays, TrueHeave can be applied directly in Merge, or during either UNB or Kongsberg sound velocity correction if such a recomputation is required.

In summary, if the POSMV reference point is different from EM710 transmit array, bugs in the Kongsberg SVC module and HIPS software release force data processing through SV correction to apply TrueHeave in order to calculate the induced heave component. In vessel installations with the TX and RX arrays installed in the typical fashion, i.e. not reverse mounted, the use of the Kongsberg SVC module typically allows for successful application of TrueHeave and does NOT introduce bathymetric artifacts. Due to unknown errors in the Kongsberg SVC, the reverse mounted arrays introduce additional data artifacts during application of TrueHeave.

## Appendix B: Correspondence with Kongsberg Maritime

This section documents correspondence with Kongsberg Maritime regarding the effects of applying a motion time delay in SIS in real-time.

### Email from Beaudoin to KUTI and Kongsberg Maritime:

From: jbeaudoin@ccom.unh.edu  
To: "Jared Harris" <jared.harris@kongsberg.com>,  
Cc: "Jeff Condiotty" <jeff.condiotty@simrad.com>, "Chuck Hohing" <chuck.hohing@kongsberg.com>, ned\_ksi@hotmail.com, "Rich Patterson" <rich.patterson@kongsberg.com>, "Jonathan Beaudoin" <jbeaudoin@ccom.unh.edu>, glen.rice.noaa@gmail.com, glen.rice@noaa.gov, "Berit Horvei" <berit.horvei@kongsberg.com>  
Date: 31.05.2013 06:40  
Subject: Re: Fw: Today's direction

Glen and I both did an extensive review of the ship survey and the sensor configurations. They are as good as they can possibly be made given that we don't have alignment angles for the IMU. We took care to handle the special roll/pitch sign convention change for the 710 TX and RX due to their reverse mounting. The array mount angles are so small that I'd consider them mostly negligible anyway...they're dialed in to SIS regardless.

We've cooked up a cruise report that we'll be passing around in the next while once we finish looking at the data.

We do have a question for you guys, perhaps more for Norway: If you input a motion time series delay in SIS for the IMU input, we understand that SIS will apply this to the soundings in real-time. Is the motion time-series written out to the file with the time delay applied? What we need to understand is whether or not to apply the time delay in post-processing or not in the case that we want to re-apply sound speed profile corrections.

jb

**Reply from Berit Horvei (Kongsberg Maritime):**

Hi

The motion delay is applied to all soundings in real-time. The motion sensor delay is stored in the Installation datagram.

The corrected time-series from the attitude sensor is stored in the attitude datagram.

So you should not need to apply the time delay if post-processing with a new sound speed profile.

Berit



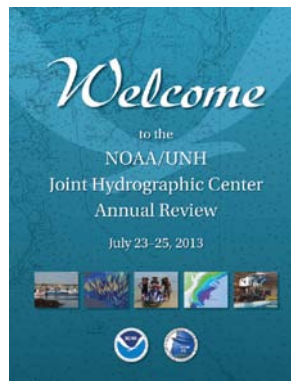
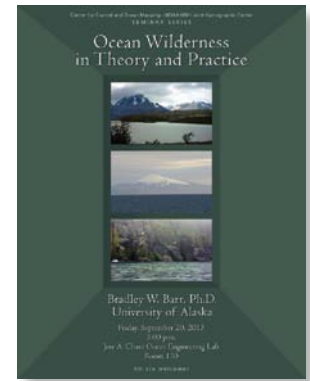
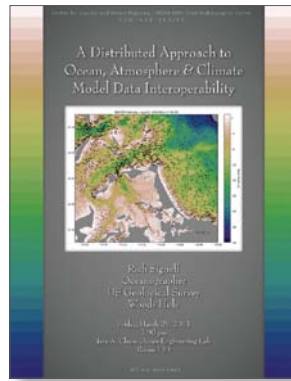
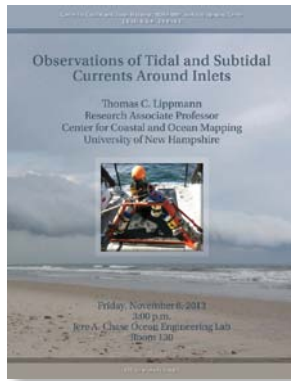
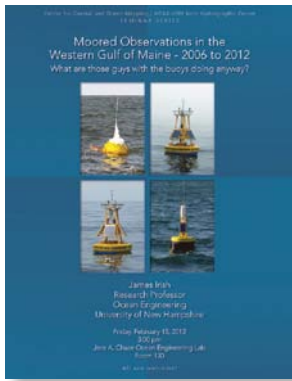
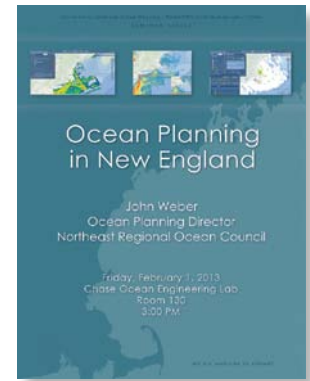
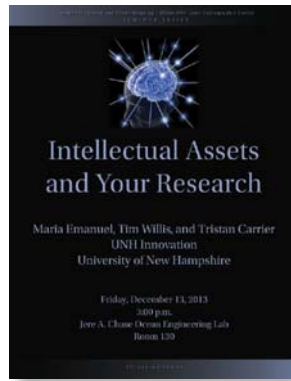
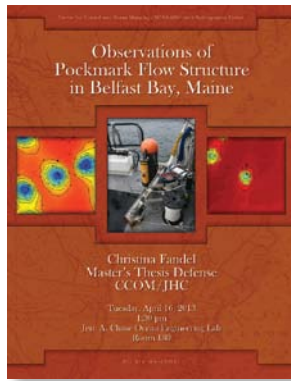
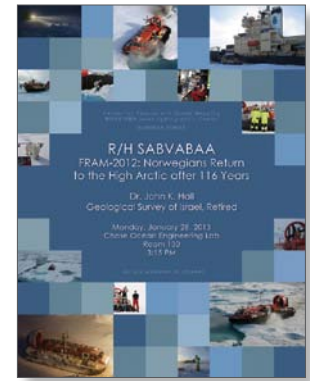
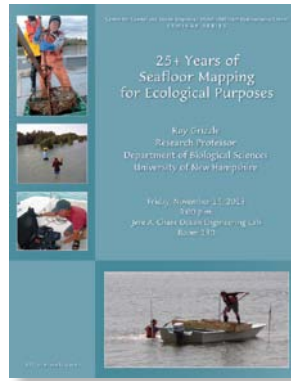
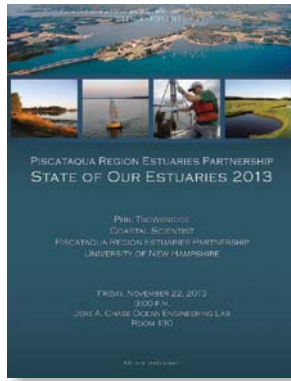
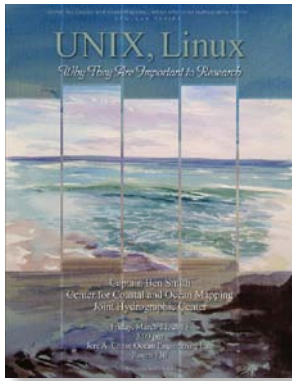

Welcome signs and flyers from the 2013 JHC/CCOM Seminar Series.

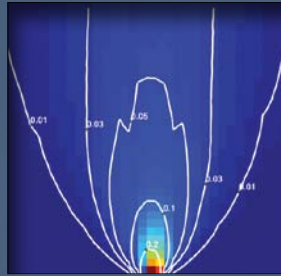
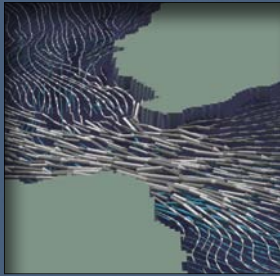
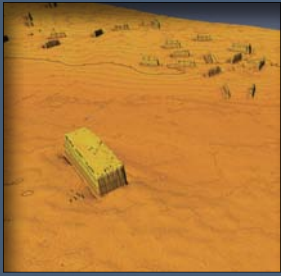

UNIVERSITY  
of NEW HAMPSHIRE

The NOAA-UNH Joint Hydrographic Center  
The Center for Coastal and Ocean Mapping

Jere A. Chase Ocean Engineering Lab  
24 Colovos Road  
Durham, NH 03824

603-862-3438 *tel*  
603-862-0839 *fax*

[www.ccom.unh.edu](http://www.ccom.unh.edu)

